



Stainless Steel 316

(contains > 2% Molybden)

Round shank
Countersunk head
Open end

UFO / SFO

extra high
corrosion resistance

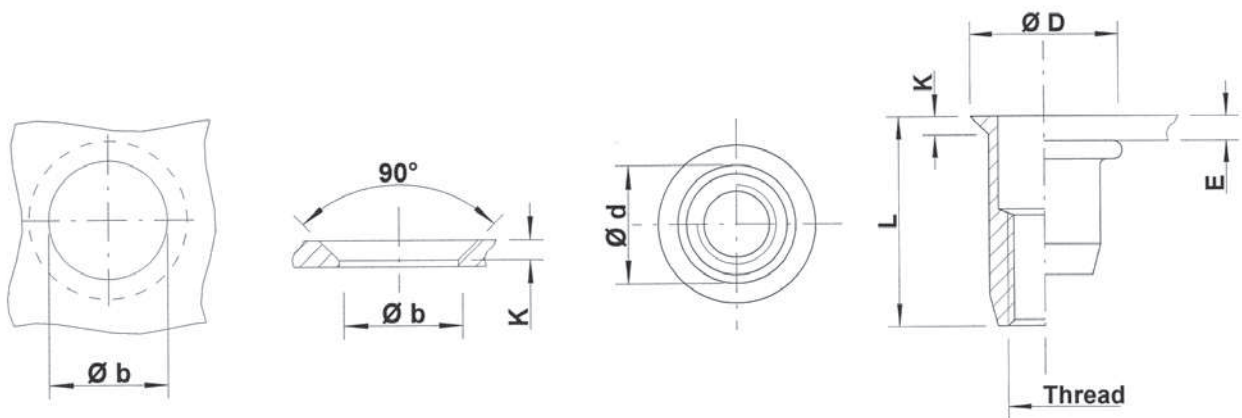

THREAD	TYPE	E = grip	L	b ^{+0,1} = drill dia	d = shank dia	D	K	kg/1000	ORDER CODE	BOX Q
M4	UFO30	1,2-3,0	12,0	6,0	6,0	8,0	1,0	1,3	554 120*	-
M5	UFO35	1,2-3,5	12,0	7,0	7,0	9,0	1,0	1,6	555 200	2000
M6	UFO45	1,7-4,5	17,0	9,0	9,0	12,0	1,5	4,2	556 125	1000
M8	UFO45	1,7-4,5	17,5	11,0	11,0	14,0	1,5	5,5	558 070	750
M10	SFO45	1,7-4,5	22,5	13,0	13,0	16,0	1,5	9,5	550 610*	-

* **Non-stock item:** minimum order quantity required after depletion of stock

All dimensions in mm - Technical data subject to modification
Tolerances and characteristics see chapter 'Technical Information'

