



Stainless Steel 316

(contains > 2% Molybden)

Semi-hexagonal shank
Flat head with underhead seal
Closed end

HDPX

watertight IP67¹

extra high
corrosion resistance

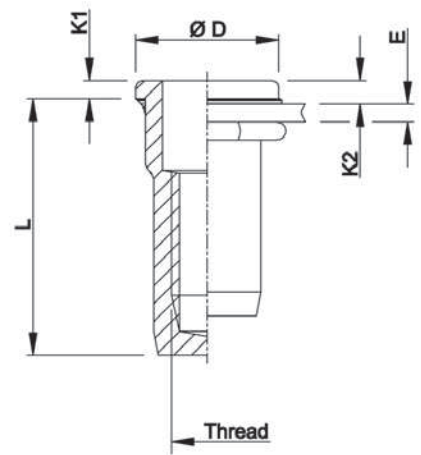
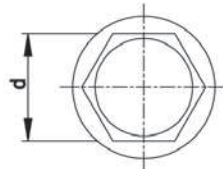
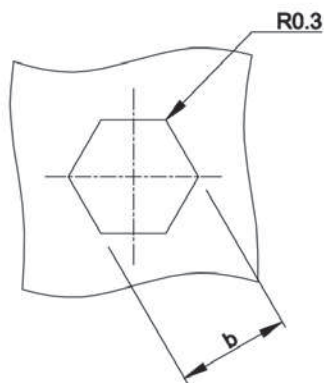

THREAD	TYPE	E = grip	L	b ^{+0,1} = hex hole	d = hex shank	D	K1	K2	kg/1000	ORDER CODE	BOX Q
M4	HDPX15	0,5-1,5	15,0	6,0	6,0	9,0	1,0	1,3	2,3	554 5205	2000
M5	HDPX20	0,5-2,0	17,5	7,0	7,0	10,0	1,0	1,3	3,1	555 5205	1500
M6	HDPX20	0,5-2,0	21,5	9,0	9,0	12,0	1,5	1,9	6,6	556 4705	750
	HDPX40	2,0-4,0	23,5							556 4755	750
M8	HDPX20	0,5-2,0	23,5	11,0	11,0	15,0	1,5	2,0	9,8	558 2605	500
	HDPX45	2,0-4,5	26,0							558 2805	500

All dimensions in mm - Technical data subject to modification

Tolerances and characteristics see chapter "Technical Data" and [pg 60](#)

¹ IP 67 guaranteed under Dejong test conditions

K2: Reference values only. Several factors (seal thickness, hole size, setting force ...) influence head and seal thickness after installation.

