



Steel

Round shank
Anti-turn head
Open end

Zinktop 480h, Cr^{VI} - free

ATO

easy repair solution:
extra high
torque-to-turn values

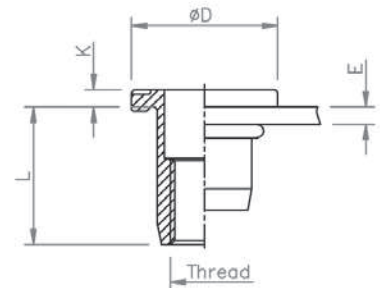
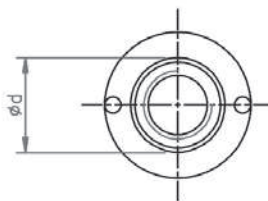
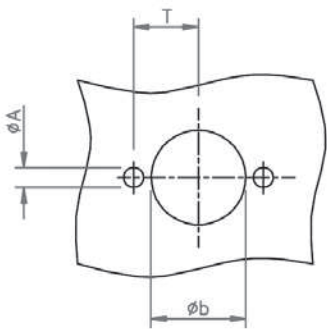

THREAD	TYPE	E = grip	L	b ^{+0,1} = drill dia	d = shank dia	D	K	A	T	kg/1000	ORDER CODE	BOX Q
M6	ATO30	0,5-3,0	14,5	9,0	9,0	14,0	1,5	1,8	6,25	4,6	526 1029*	1750
M8	ATO30	0,5-3,0	16,0	11,0	11,0	17,0	2,0	2,3	7,5	7,4	528 1022*	1200
M10	ATO35	0,8-3,5	21,0	13,0	13,0	19,0	2,0	3,0	8,75	11,4	520 1609*	750

Tool to position Ø A:

M6	AT 206
M8	AT 208
M10	AT 210



Samples available from stock

All dimensions in mm - Technical data subject to modification
Tolerances and characteristics see chapter 'Technical Information'

