

ELS3 Electric height adjustment
for sit-stand workplaces



Flexible modular system for sit-stand workplaces

With the modular system ELS3 you can construct four different table frames. The striking feature are their solid design, easy assembly and the wide range of applications. The frames were specifically designed for our ELS3 range of adjustable legs (see pages 4 and 5) controllers and switches (see pages 10 and 11).

VariFrame

adjustable cross beam

page 6

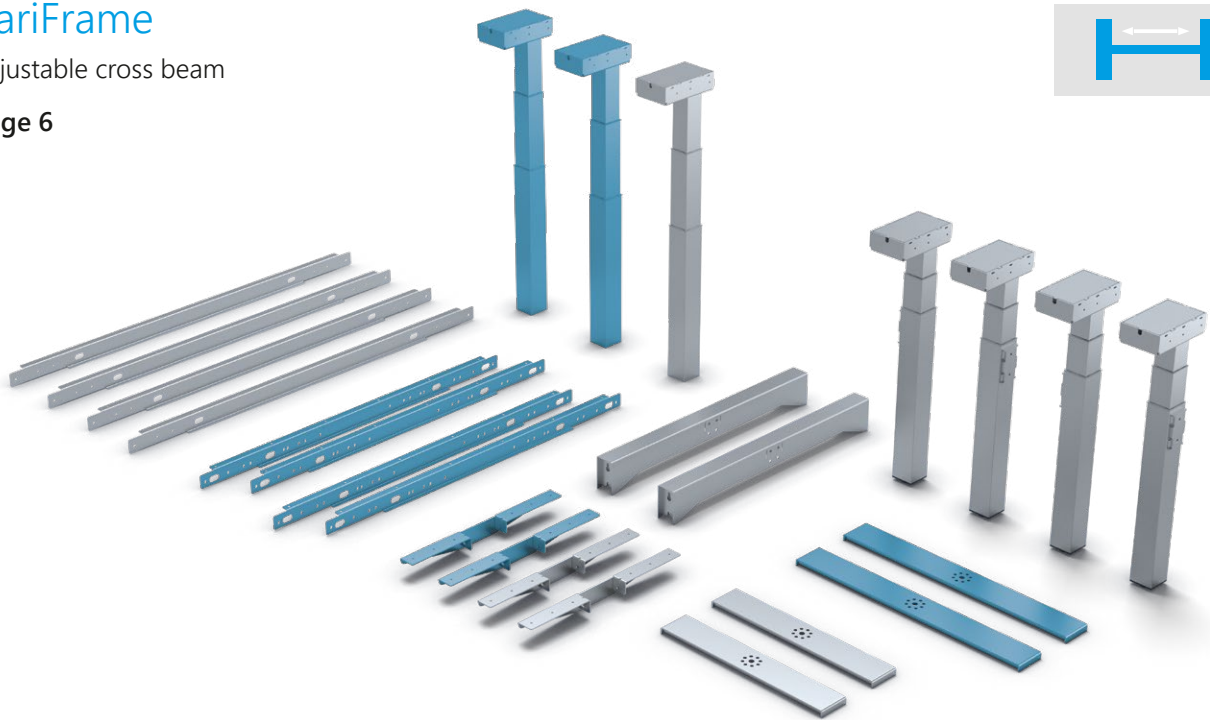

FixFrame

fixed cross beam in five lengths

page 7



Table frame

for duo workplaces (bench)

page 8

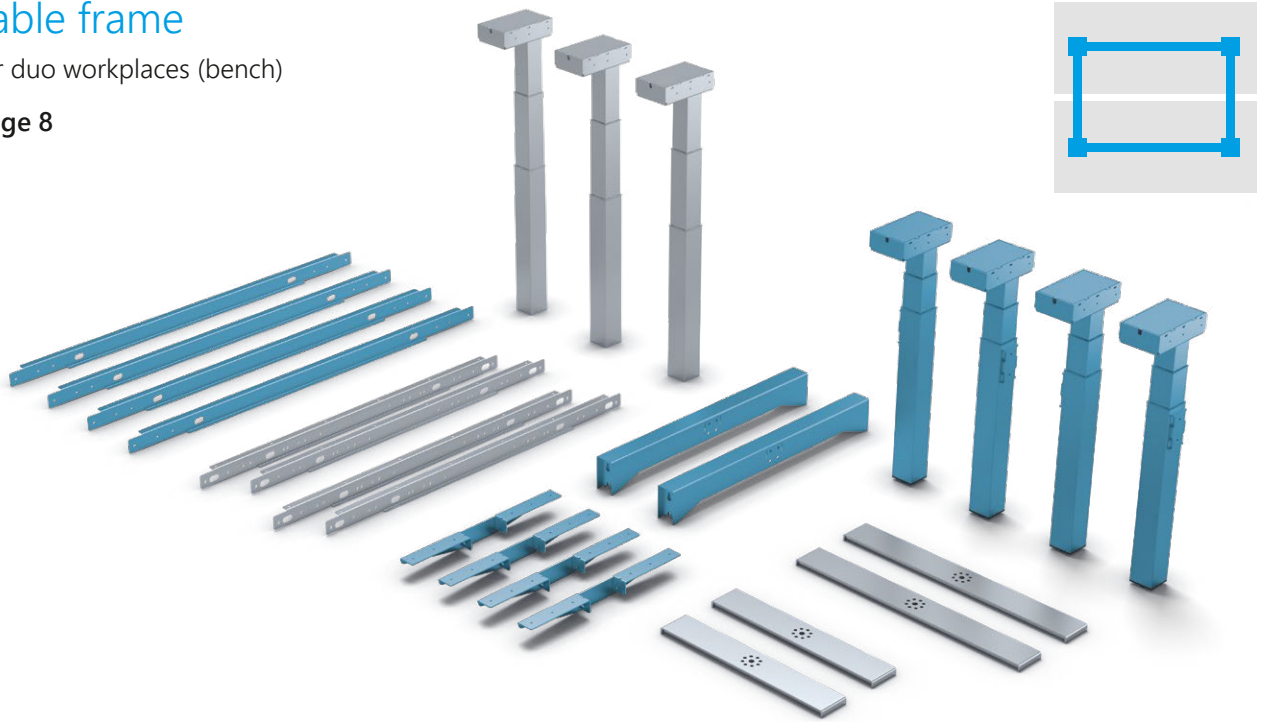

3-leg-table frame

for corner desks

page 9

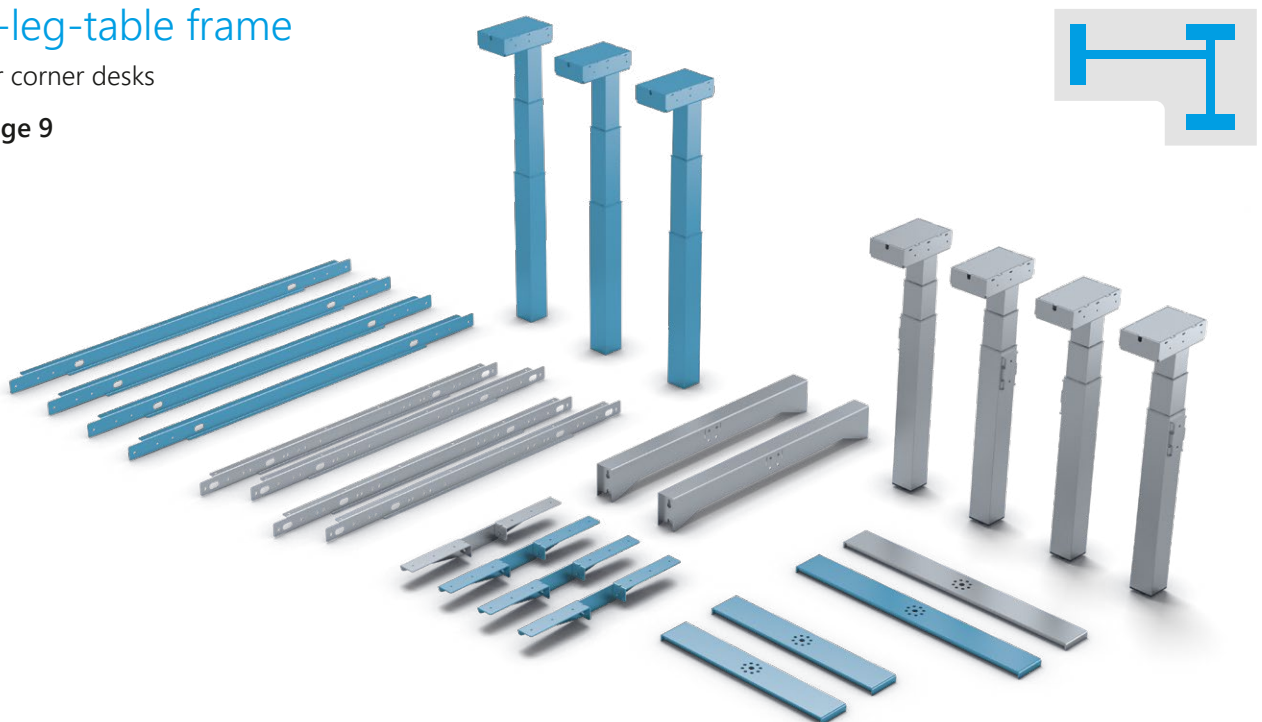

ELS3 Electric lifting columns at a glance

With the electrical lifting column ELS3 from SUSPA you can easily change your working position from sit to stand. The main features of the lifting columns are elegant design, quiet movement (<48dB) and a long adjustment range. All ELS systems have the option to have collision detection, which will stop the system automatically if an obstruction is detected.



Lifting column
square version

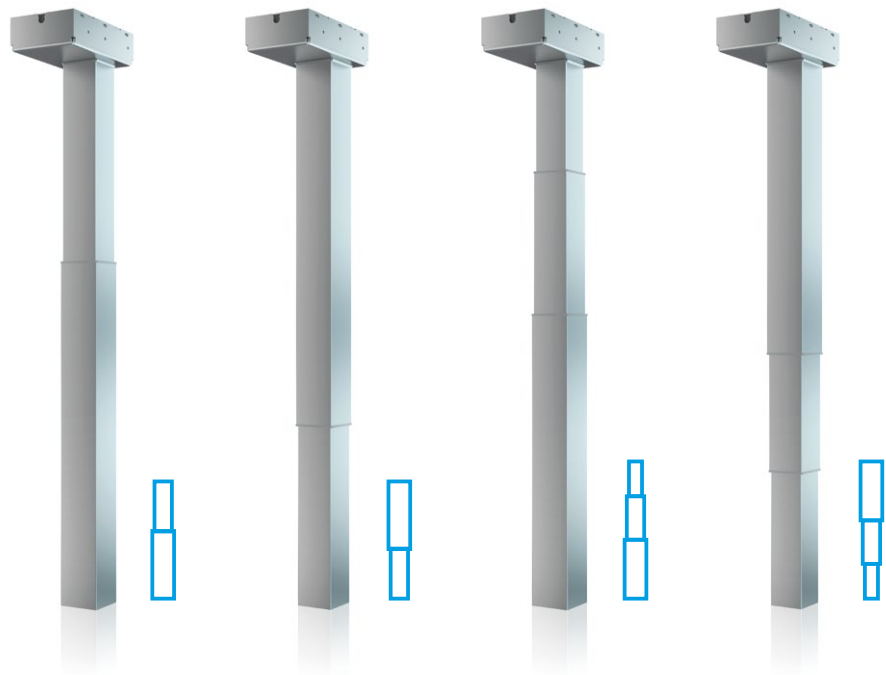

Model name	ELS3-500S-BTD-Q	ELS3-500S-BTU-Q	ELS3-650-BTD-Q	ELS3-650-BTU-Q
Profile	square version			
Position of big tube	Big Tube Down (BTD)	Big Tube Up (BTU)	Big Tube Down (BTD)	Big Tube Up (BTU)
Material	steel profile			
Color	● silver-gray RAL 9006	○ white RAL 9003	● black RAL 9005	● graphite similar to RAL 7024 further colors available on request
Design	1-stage telescopic	1-stage telescopic	2-stage telescopic	2-stage telescopic
Compressed length	650 mm	650 mm	565 mm	565 mm
Adjustment range (stroke)	500 mm	500 mm	650 mm	650 mm
Extended length	1,150 mm	1,150 mm	1,215 mm	1,215 mm
Maximum load	with controller SMARTneo with controller COMPACT	60 kg per leg -	60 kg per leg -	60 kg per leg 60 kg per leg
Adjustment speed	35 mm/s	35 mm/s	38 mm/s	38 mm/s
Dimensions of column	top middle bottom	65 x 65 mm - 70 x 70 mm	70 x 70 mm - 65 x 65 mm	60 x 60 mm 65 x 65 mm 70 x 70 mm
Dimensions of motor casing/top	202 x 120 x 55 mm			
Fixing for the footbase	4 x M8			



Further colors available on request



Lifting column
rectangle version

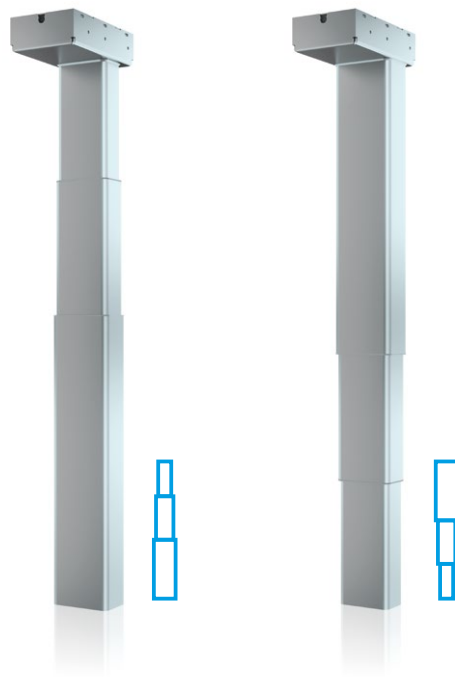

Model name		ELS3-650-BTD-RE	ELS3-650-BTU-RE
Profile		rectangle version	
Position of big tube		Big Tube Down (BTD)	Big Tube Up (BTU)
Material		steel profile	
Color		 silver-gray RAL 9006 white RAL 9003 black RAL 9005 graphite similar to RAL 7024 further colors available on request	
Design		2-stage telescopic	2-stage telescopic
Compressed length		565 mm	565 mm
Adjustment range (stroke)		650 mm	650 mm
Extended length		1,215 mm	1,215 mm
Maximum load	with controller SMARTneo	60 kg per leg	60 kg per leg
	with controller COMPACT	60 kg per leg	60 kg per leg
Adjustment speed		38 mm/s	38 mm/s
Dimensions of column	top	95 x 55 mm	107 x 67 mm
	middle	101 x 61 mm	101 x 61 mm
	bottom	107 x 67 mm	95 x 55 mm
Dimensions of motor casing / top		202 x 120 x 55 mm	
Fixing for the footbase		4 x M8	

Electrically adjustable table base frames

VariFrame

The adjustable table base VariFrame comes with a split cross beam which is variable and can be adjusted to different table top sizes.

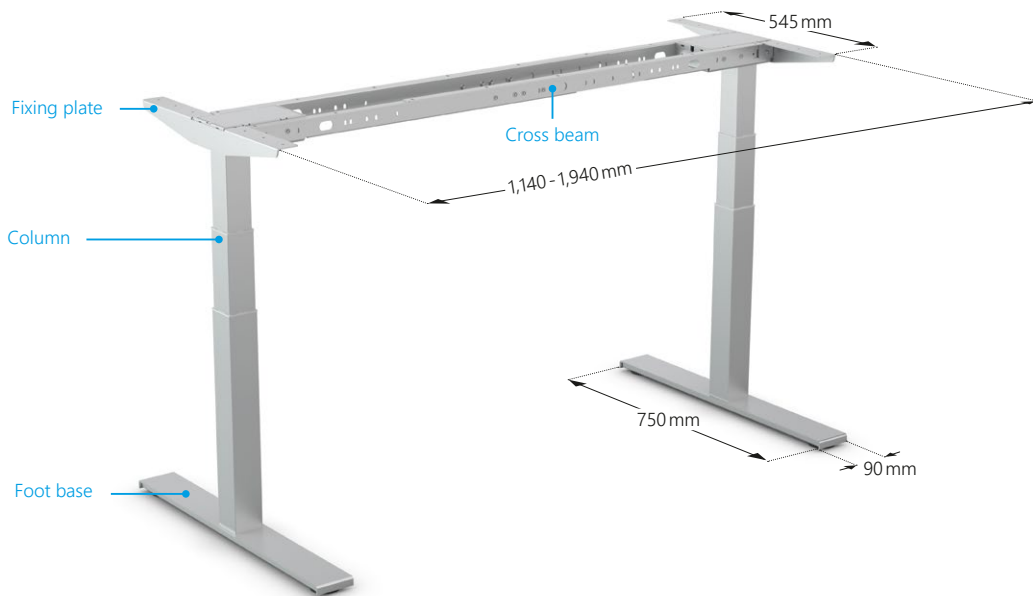

Model name		Table base frame VariFrame			
Color		● silver-grey RAL 9006	○ white RAL 9003	● black RAL 9005	● graphite similar to RAL 7024
Cross beam	length	two-piece traverse, adjustable length of frame from 1,140 mm to 1,940 mm			
Desk top dimensions	length	1,200 - 2,000 mm			
	depth	700 - 800 mm			
Material		steel profile			
Fixing plate	length	545 mm			
Adjustment range (stroke) until top of frame		ELS3-500S: 680 - 1,180 mm ELS3-650: 595 - 1,245 mm			
Maximum load table frame		100 kg			
Adjustment speed		ELS3-500S: 35 mm/s ELS3-650: 38 mm/s			
Accessories		screws, adjustable feet			
For lifting columns		can be combined with all SUSPA columns			
Foot base	length	750 mm			
	depth	90 mm			
	height	30 mm			

FixFrame

The table base FixFrame consists of a fixed cross beam, available in five different sizes.

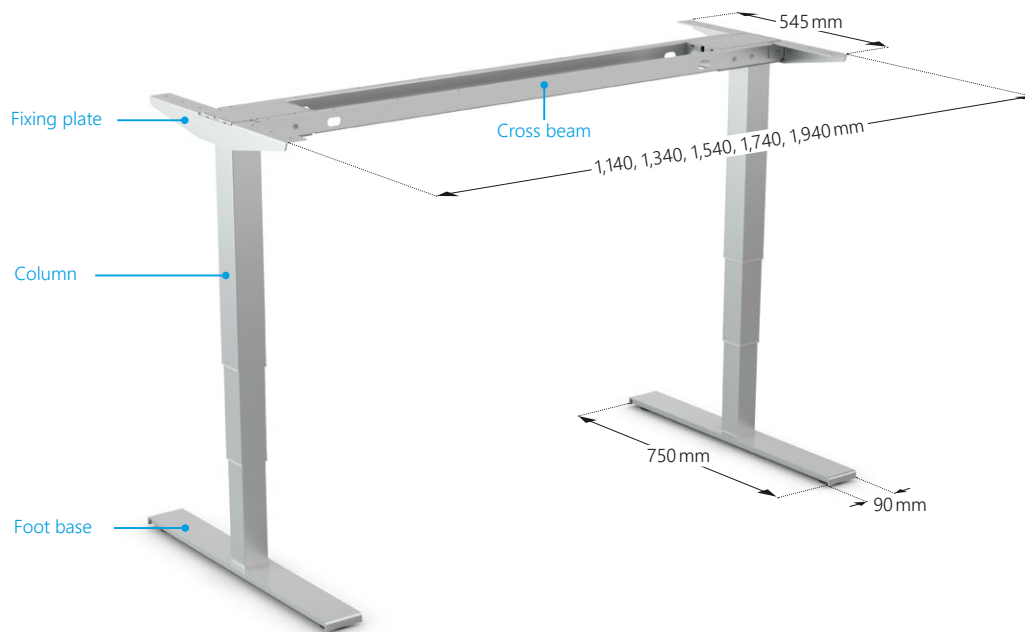

Model name		Table base frame FixFrame			
Color		● silver-grey RAL 9006	○ white RAL 9003	● black RAL 9005	● graphite similar to RAL 7024
Cross beam	length	fixed cross beam lengths: 1,140 mm, 1,340 mm, 1,540 mm, 1,740 mm, 1,940 mm			
Desk top dimensions	length depth	1,200 mm, 1,400 mm, 1,600 mm, 1,800 mm, 2,000 mm 700 - 800 mm			
Material		steel profile			
Fixing plate	length	545 mm			
Adjustment range (stroke) until top of frame		ELS3-500S: 680 - 1,180 mm ELS3-650: 595 - 1,245 mm			
Maximum load table frame		100 kg			
Adjustment speed		ELS3-500S: 35 mm/s ELS3-650: 38 mm/s			
Accessories		screws, adjustable feet			
For lifting columns		can be combined with all SUSPA columns			
Foot base	length depth height	750 mm 90 mm 30 mm			

Electrically adjustable table base frames

for duo workplaces

For team-workplaces we offer a complete table base frame suitable for table tops from 1,200 to 2,000 mm. With the so called bench solution you will achieve the ideal use of space in your office.

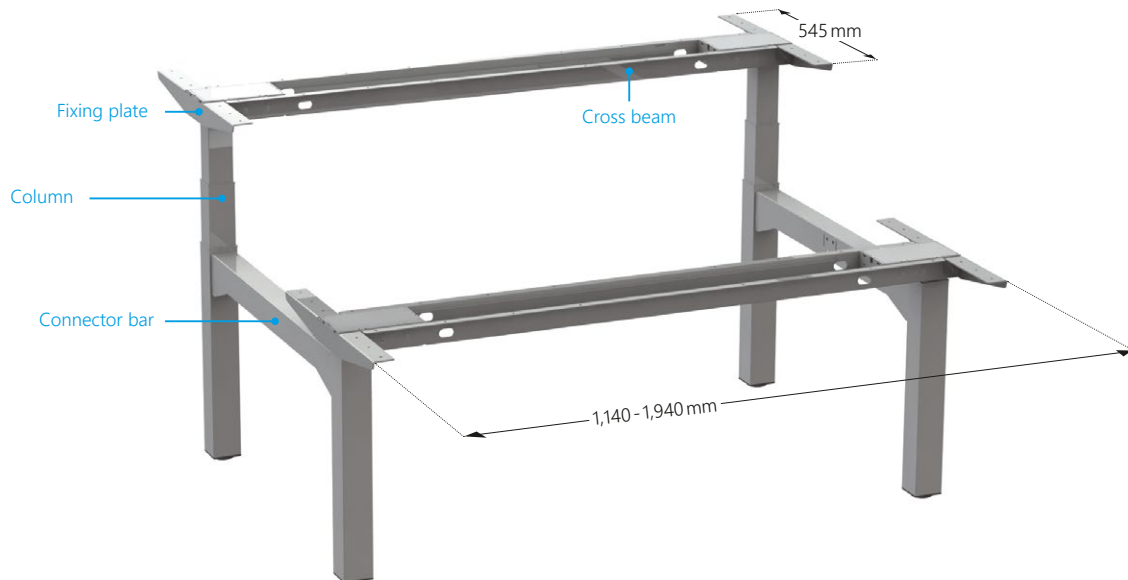

Model name		Table base frame Bench			
Color		● silver-grey RAL 9006	○ white RAL 9003	● black RAL 9005	● graphite similar to RAL 7024
Cross beam	length	see VariFrame or FixFrame, pages 6 and 7			
Desk top dimensions	length	1,200 mm, 1,400 mm, 1,600 mm, 1,800 mm, 2,000 mm			
	depth	700 - 800 mm			
Material		steel profile			
Fixing plate	length	545 mm			
Adjustment range (stroke) until top of frame		606 - 1,256 mm			
Accessories		screws, expander plugs with adjustable sliding feet			
For lifting columns		for all square lifting columns BTD (Big Tube Down)			

for corner desks

Our 3-leg-table frame offers a very big work place for corner desks.

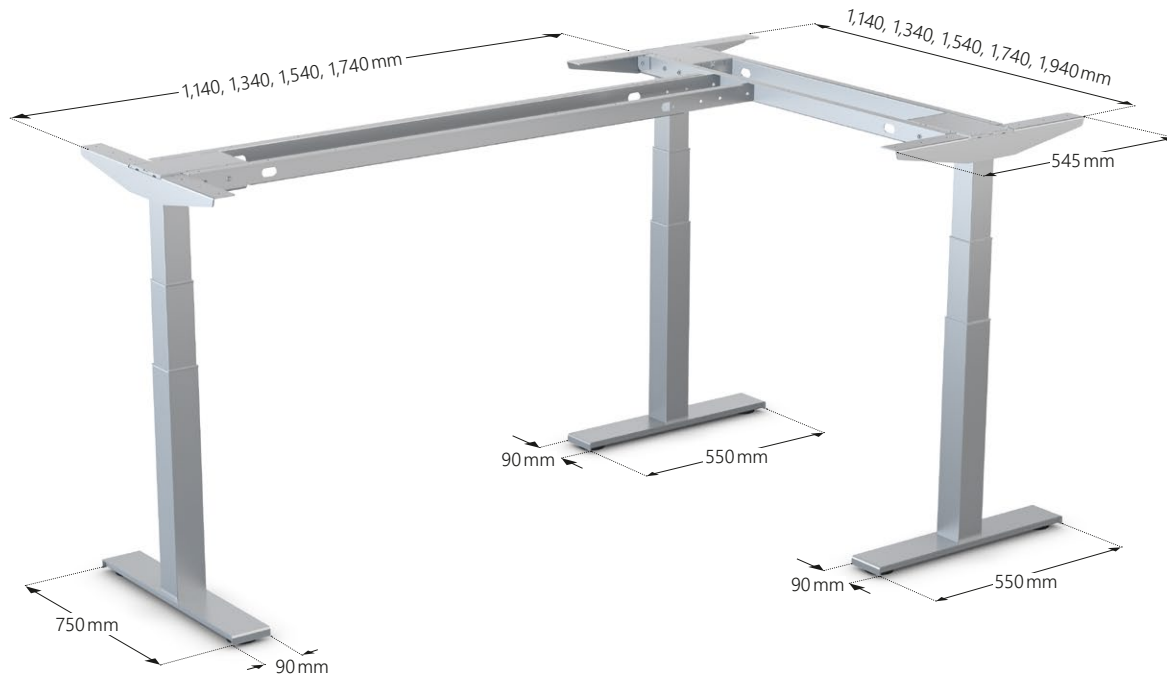
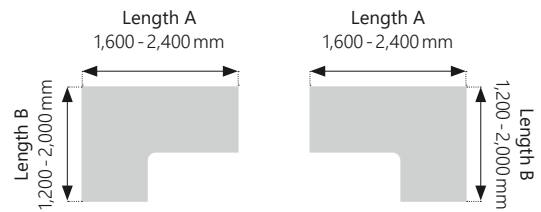

Model name		Table base frame corner desk			
Color		<input type="radio"/> silver-grey RAL 9006	<input type="radio"/> white RAL 9003	<input type="radio"/> black RAL 9005	<input type="radio"/> graphite similar to RAL 7024
Cross beam	length	fixed cross beam: 1,140 mm, 1,340 mm, 1,540 mm, 1,740 mm, 1,940 mm adjustable cross beam: 1,140 mm - 1,940 mm			
Desk top dimension		see pictogram above			
Material		steel profile			
Fixing plate (3 pieces)	length	545 mm			
Adjustment range (stroke) until top of frame		ELS3-500S: 680 - 1,180 mm ELS3-650: 595 - 1,245 mm			
Maximum load table frame		150 kg			
Adjustment speed		ELS3-500S: 35 mm/s ELS3-650: 38 mm/s			
Accessories		screws, adjustable feet			
For lifting columns		can be combined with all SUSPA columns			
Foot base	length depth height	1x750 mm und 2x550 mm 90 mm 30 mm			

Accessories and switches

Accessories

The highly efficient control boxes have a flat and compact design. In combination with the switches they guarantee a reliable and economical operation of the tables.

SMARTneo controller

- low standby power consumption: $\leq 0,1W$
- Soft-Start and Soft-Stop
- integrated anti-collision sensor with high sensitivity (light barrier)
- integrated anti-collision software ISP installed
- weight: 312 g
- dimensions: 188x85x35 mm
- controls for EU- and US-voltage available
- supply voltage
EU: 220 - 240VAC / 50-60Hz, US: 100 - 120VAC / 50 - 60Hz
- nominal voltage
EU: 230V / 50Hz, US: 120V / 60Hz
- output voltage: 240W (2-leg) 24VDC
- operating time 10% at maximum load (1min/9min)
- sit/stand memory for basic hand switches is possible



COMPACT controller

- low standby power consumption: $\leq 0,3W$
- Soft-Start and Soft-Stop
- overload protection
- weight: 418g/523g (3-leg-controller)
- dimensions: 264x103x37 mm
- controls for EU- and US-voltage available
- supply voltage
EU: 207 - 254,4V / 50Hz, US: 90 - 127V / 50 - 60Hz
- nominal voltage: 230V / 50Hz, US: 120V / 60Hz
- output voltage: 288VA (2-leg) 24VDC / 360VA (3-leg) 24VDC
- operating time: 10% at maximum load (1min/9min)
- external sensor collision detector possible with LOGIC-CONNECTOR



Communication and Connectivity LOGIClink

LOGIClink provides connectivity and control, allowing for communication and customization of the user's work environment.



Power cable

available for the control boxes COMPACT and SMART for different countries

Switches

We provide solutions for an installation below the table and within the table top. From a simple hand switch with Up/Down function to a comfort switch with four memory functions and display – all operational elements convince through their surface design and the pleasing haptics.



Hand switch Up-Down
HSM-OD-2-LD



Hand switch Memory
HSU-C-FL-LD



Hand switch Up-Down
TOUCHbasic DN



Hand switch Memory, Inlay
TOUCHinlay

Ergonomics at the workplace

Over the last few years, SUSPA has become established as one of the leading suppliers of electric height adjustment systems. The topic of ergonomics at the workplace has increasingly gained importance in companies as well in recent years.

Since more and more people are experiencing back problems due to a lack of movement, it is not only the personal well being that is affected, but there is also enormous economic damage done through absences from work. The best way of countering the lack of movement in the office is to use sit-stand desks.



SUSPA GmbH Mechanical Applications

Industriestr. 12-14
90518 Altdorf
Germany

Phone +49 9187 9300
Fax +49 9187 930311

infoindustry@de.suspa.com
www.suspa.com

www.suspa.com