

# BRACKET FOR DISK DAMPER UDD-BKT

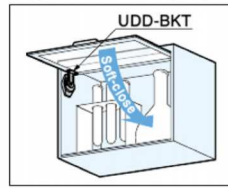

[Application Example]



- Bracket of disk damper UDD 1 for upward-opening doors.

[Remarks]

- Chamfer edge of top board to reduce the gap between the door and top board by referring to Fig.2 and Table 2 (recommended).
- Install a stopper on the cabinet (Fig.3).
- Catch is needed for holding door in opened position.
- Face plate SDS for glass door and spacer SDS-50G 2 available for glass/acrylic doors.

TORQUE HINGES

DAMPER HINGES

LIFT ASSIST HINGES

DETENT HINGES

CONCEALED HINGES

BUTT HINGES

PIANO HINGES

STEP HINGES

LIFT-OFF HINGES

PIVOT HINGES

SPRING HINGES

CLEAN ROOM HINGES

HINGES FOR ALUMINIUM FRAME

DROP HINGES

GLASS DOOR HINGES

SPECIAL HINGES

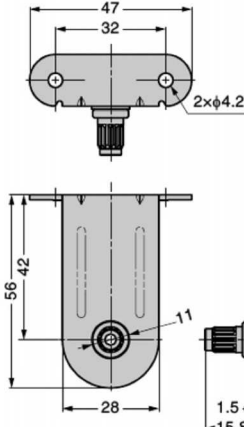

[Installation]

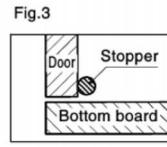
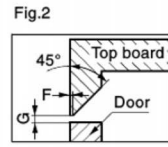
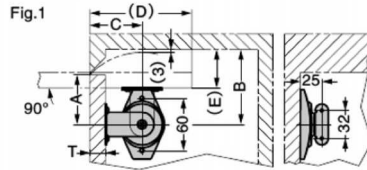

Table 1

No.	Door Thickness T	A	B	C	D	E
①	5	46	70	49	( 95)	(26)
②	15	54	82	57	(111)	(40)
③	18	57	86	60	(117)	(44)

※ ① is the value when using acrylic or glass door with a door thickness of 5 mm, a face plate SDS for glass door, and spacer SDS-50G.  
 ②③ are the values when using wooden doors with door thicknesses given in the above table.

Table 2

Chamfering Allowance F	Gap G
1	3
2	4
3	5

RoHS	CAD	Item Code	Item Name	Material	Finish	Weight (g)	Carton (pcs)
G	3D	180-026-764	UDD-BKT	Stainless Steel (SUS304)	Plain	33	60

Refer to 1 : P.119, 2 : P.369

# LIFT-ASSIST DAMPER LAD®, LAD®-ST DIGEST



- Ideal for the top board of counter entrance.
- Supplied with LAPCON mechanism, damper works during closing and top board slowly closes. Damper works even at a slight opening angle.
- Lift-assist function allows opening the top board easily.
- Can be retrofitted to existing counters without machining.
- Installation position can be easily determined with the supplied template.



Sasuga-kun



LAD 1



LAD-ST (with stopper) 2  
Stops at 95° opening.

Refer to 1 : P.330, 2 : P.328

製品内容 Parts list

お客様にてご用意いただく商品 Parts that Customer should provide

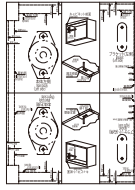
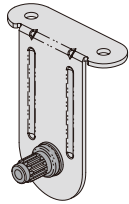

- ブラケット: 1 個  
Bracket : 1 piece
- テンプレート: 1 枚  
(本書裏面)  
Installation  
Template : 1 piece  
(See reverse)

【木製什器の場合】  
In case of wooden furniture

(ブラケット用)  
for bracket



- 十字穴付キトラスタッピンねじ  
呼び 3.5×L ※1: 4 個  
Truss tapping screw  
3.5×L ※1: 4 pieces

(ダンパー本体用)  
for UDD main body



- 十字穴付キトラスタッピンねじ  
呼び 5×L ※1: 4 個  
Truss tapping screw  
5×L ※1: 4 pieces

※1 ねじの長さ(L)は扉厚 -3mmを目安にご用意ください。  
Length of the screw (L) :  
door(side board) thickness -3mm

【アクリル(ガラス)や板金什器の場合】  
In case of acrylic(glass)/metal furniture



- SDSガラス扉用フェースプレート: 2 個  
SDS face plate : 2 pieces  
(アクリル又はガラス扉)



- スペーサー: 4 個  
Spacer : 4 pieces  
(アクリル又はガラス扉)

(ブラケット用)  
for bracket



- 十字穴付キトラス小ねじ  
M4×L ※2: 4 個  
Truss machine screw  
M4×L ※2: 4 pieces

(ダンパー本体用)  
for UDD main body



- 十字穴付キトラス小ねじ  
M5×8: 4 個  
Truss machine screw  
M5×8: 4 pieces

※2 SDS フェースプレート(スペーサー)を使用する場合、ねじの長さ(L)は扉厚 +7mmを目安にご用意ください。  
Length of the screw (L) : door thickness +7mm  
(in case SDS face plate and spacer used)

取付寸法図 Installation drawing (裏面のテンプレートをご使用ください)



図1 (Figure 1)

表1 (Table 1)

扉厚 T [mm]	開き角度(Opening angle) 90°				
	A	B	C	D	E
18	57	86	60	(117)	(44)
15	54	81.5	57	(111)	(40)
5	46	70	49	(95)	(26)

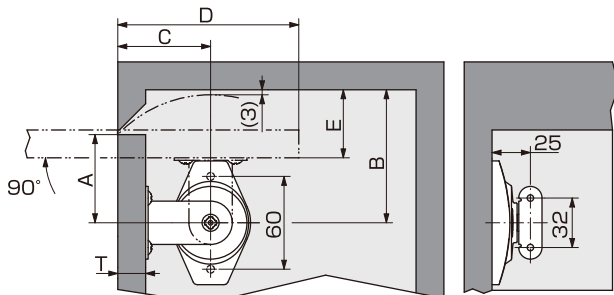

図2 (Figure 2)



図3 (Figure 3)

※扉上部と天板との隙間を少なくする為、筐体を図2及び表2を参考に面取り加工をしてください(推奨)。  
※筐体には戸当たりを設けてください(図3)。

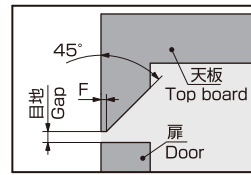
※Please process the cabinet according to Figure 2 and Table 2 in order to reduce the gap between the top board and the door.  
※Please install a stopper in the cabinet.(Figure3)

表2 (Table 2)

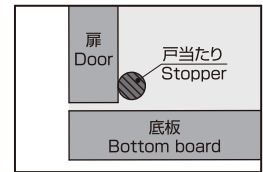
F [mm] 面取り加工の残り (The rest of the Chamfering)	目地(gap) [mm]
1	3
2	4
3	5

取付手順 ※左右同様に取付けてください。 Installation ※Left and right bracket should be positioned symmetrically.

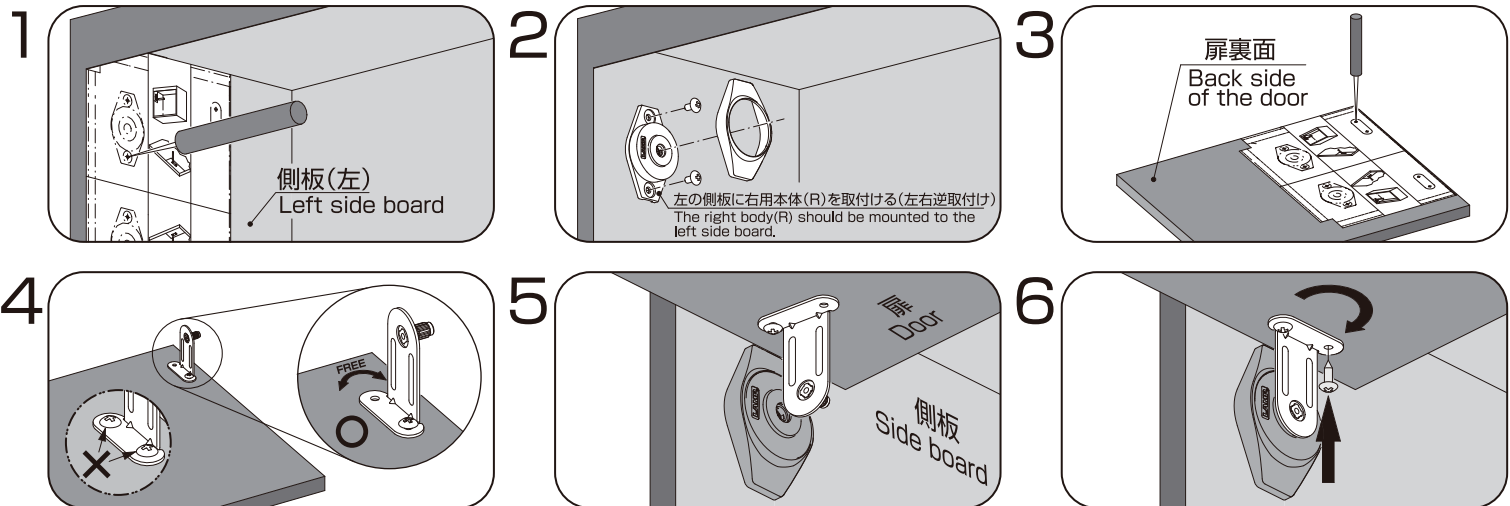

本製品に関するご質問・ご相談は、お買い求めいただいた販売店、または下記の窓口にお問い合わせいたします。

電話番号 03 (3864) 1122

受付時間 月~金 9:00~17:30 (年末・年始・夏季休暇等は除く)

FAX 03 (3863) 6875

E-mail : support@sugatsune.co.jp

東京都千代田区岩本町2-5-10 〒101-0032

SUGATSUNE スガツネ工業  
LAMP 印の機能&デザイン金物メーカー

ISO 9001 (JSAQ384) ・ ISO 14001 (JSAE597) 審査登録  
※ISO9001:物流 WEST を除く、国内拠点 ※ISO14001:千葉工場および物流センター (SBC)  
https://www.sugatsune.co.jp/

SUGATSUNE KOGYO CO.,LTD.  
Phone: +81 3 3866 2260  
F a x : +81 3 3866 4447  
E-mail: export@sugatsune.co.jp  
Website: www.sugatsune-intl.com

SUGATSUNE KOGYO (UK) LTD.  
Phone: +44 118 9272 955  
F a x : +44 118 9272 871  
E-mail: sales@sugatsune.co.uk  
Website: www.sugatsune.co.uk

SUGATSUNE AMERICA, INC.  
Phone: +1 310 329 6373  
F a x : +1 310 329 0819  
E-mail: sales@sugatsune.com  
Website: www.sugatsune.com

SUGATSUNE SHANGHAI CO., LTD.  
Phone: +86 21 3632 1858  
F a x : +86 21 3632 1868  
E-mail: lamp@sugatsune.com.cn  
Website: www.sugatsune.com.cn

