

# MONOFLAT LIN-X HINGE LIN-X450, LIN-X600

INSTRUCTION

## MonoFlat LIN-X hinge®



	LIN-X450 <span style="color: blue;">1</span>	LIN-X600 <span style="color: blue;">2</span>
Door Width	400~500 mm	550~650 mm
Door Height	600~2400 mm	
Door Thickness	15~24 mm	
Door Weight	Max. 17 kg/Door	Max. 24 kg/Door
Overlay	19 mm	
Specification	<input type="checkbox"/> Single Door (Overlay)	

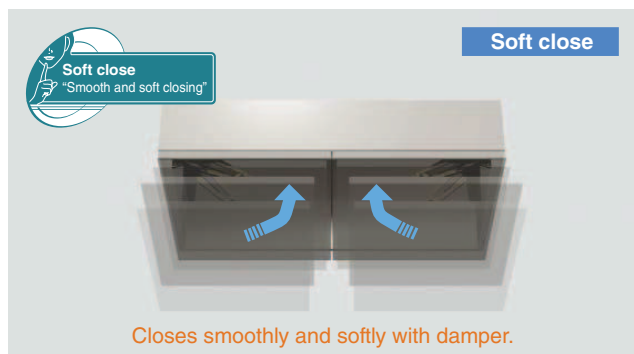

### Door does not get in the way even when fully opened

- Door will be flush with left and right doors when closed.
  - Door does not get in the way during and after being opened. Swings out laterally in small radius, ideal for tight front space application.
  - Full access to cabinet! Maximising inside space. Installed to cabinet side board, maximising space inside of cabinet.
  - Smooth operation Door can be opened and closed smoothly from any position.
  - Soft close Door closes smoothly and softly with damper.
  - Easy installation Arms are clipped on base.
  - 4-way adjustable Adjustable in vertical, horizontal, depth and parallel directions.
  - Various applications Allows to combine single door and double door, suitable for various cabinets. L-shaped corner use also possible.

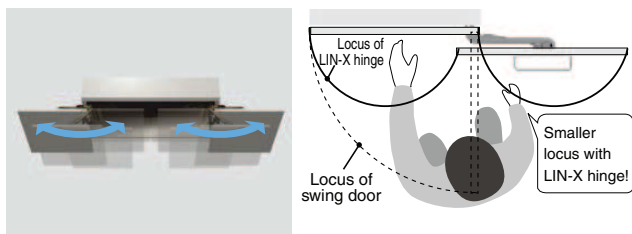

- Allows to swing out laterally in small radius, ideal for tight front space application.



- Installed to side board, not interfering with taking in/out of articles. Suitable for hanging doors and floor cabinets.
- Easy installation and removal.

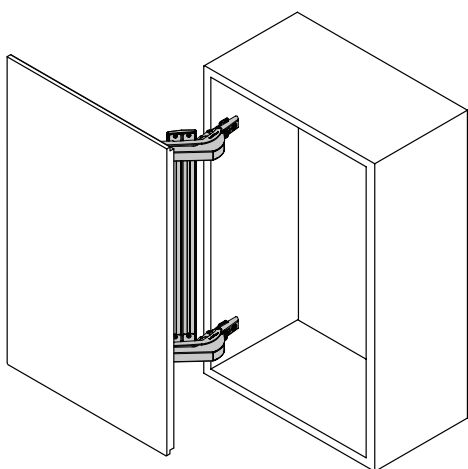

2 hinges per door shown.

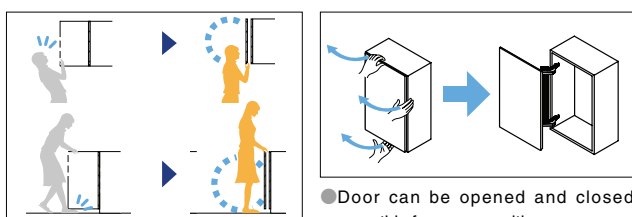

- Door does not get in the way when opening and closing.

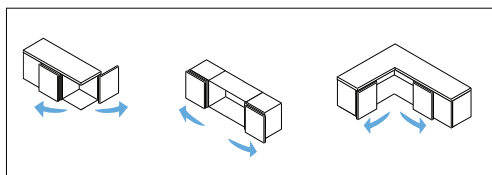

- Suitable for various cabinets.



Refer to 1 : P.805, 2 : P.808

INSTRUCTION

**LIN-X450 Installation Example**

Door specifications [Width: 400~500mm] [Thickness: 15~24mm] [Height: 600~2400mm] [Weight: Max. 17kg/door] [Overlay: 19mm for standard type]

The circled numbers are part numbers. Please check with the parts list 1. For LIN-X600, refer to 2.

[Locus Chart]

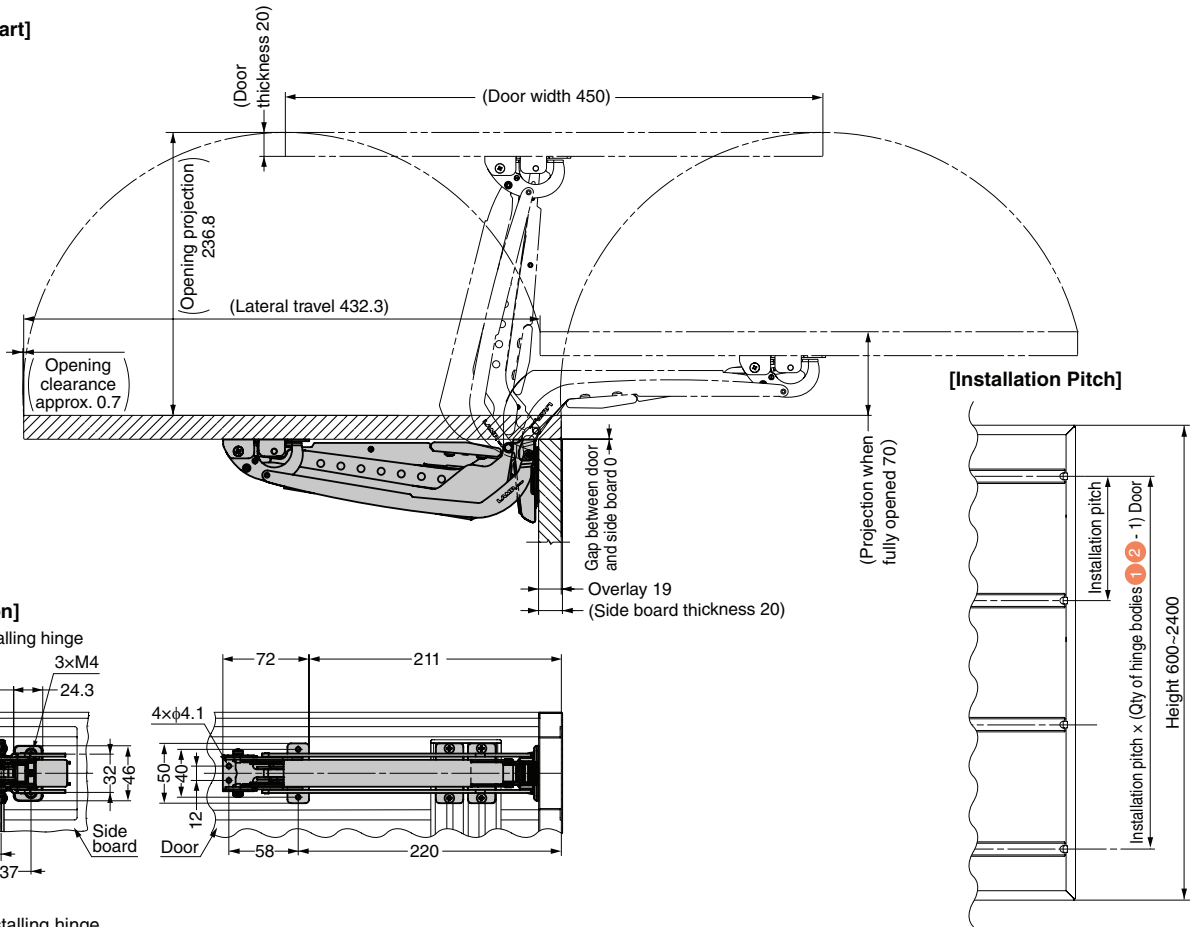

[Installation]

● When installing hinge

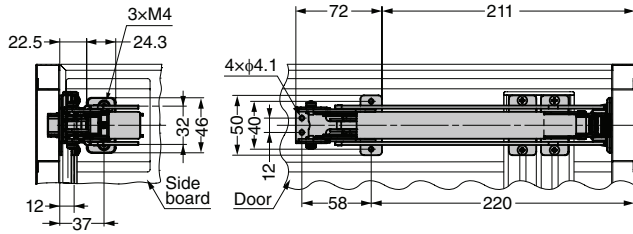

● Before installing hinge

※Chamfer the mounting hole. (φ5.2)

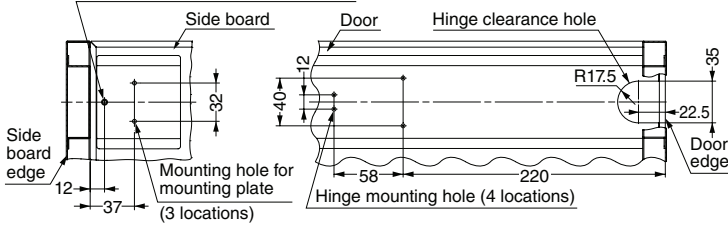

Qty of Hinge Bodies (1 + 2)	Item Name Suffix of Parts Set					
	09XX	12XX	15XX	18XX	21XX	24XX
	Connecting Bar (3) Length L					
2 Hinges per Door	490	790	1090	-	-	-
3 Hinges per Door	245	395	545	695	845	-
4 Hinges per Door	-	263	363	463	563	663
5 Hinges per Door	-	-	272.5	347.5	422.5	497.5

[Parts Drawings]

● Hinge body  
When closed

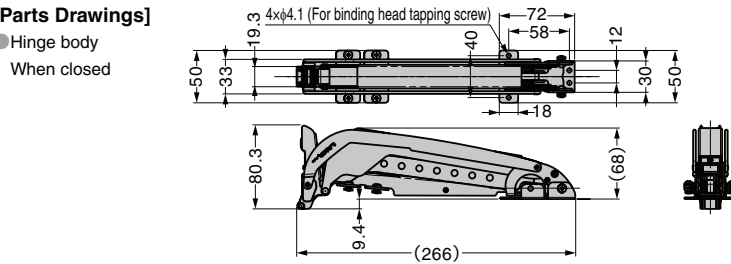

When opened

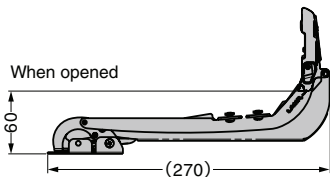

● Hole cover

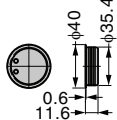

● Connecting bar

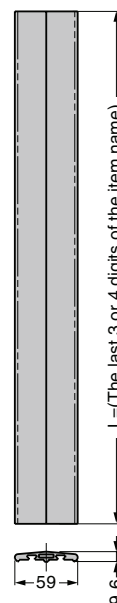

● End cap for connecting bar

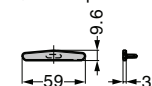

Refer to 1 : P.806~P.807, 2 : P.810

When Ordering MonoFlat  
LIN-X Hinge LIN-X450





● Necessary Parts..... **Parts Set (Per Door)** + **Mounting Plate**

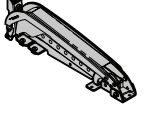

● Standard kit **1** including mounting plates also available, suitable for door height 600~900mm and door weight 7kg or less.

		Parts Set (Per Door)		Necessary Parts								
				Choose based on applicable door height and door weight. (Refer to <b>2</b> for details on dimensions and descriptions of parts included in the set.)								
RoHS	CAD	Item Code	Item Name	Door Height mm	Door Weight kg	Parts Included (For LIN-X450)					Weight (g)	
						① Hinge Set (With Catch & Damper)	② Hinge Set (Without Catch & Damper)	③ Connecting Bar		④ End Cap For Connecting Bar		
						Qty/set	Qty/set	Connecting Bar Item Name	Qty/pc	Qty/pc		
		250-016-701	LIN-X450S-0907	600~	Max. 7	2		LIN-X45-L540			4046	
		250-016-702	LIN-X450S-0910	900	7.1~10.5	3					4812	
		250-016-703	LIN-X450S-1207		Max. 7	2					4193	
		250-016-704	LIN-X450S-1210	901~	7.1~10.5			LIN-X45-L840			4959	
		250-016-705	※1 LIN-X450S-1214	1200	10.6~14	3	1				5661	
		250-016-706	LIN-X450S-1507		Max. 7	2					4416	
		250-016-707	LIN-X450S-1510	1201~	7.1~10.5			LIN-X45-L1140			5182	
		250-016-708	※1 LIN-X450S-1514	1500	10.6~14		1				5884	
		250-016-709	※2 LIN-X450S-1517		14.1~17		2				6586	
		250-016-710	LIN-X450S-1807		Max. 7						5512	
		250-016-711	LIN-X450S-1810	1501~	7.1~10.5			LIN-X45-L1440	1	2	5512	
		250-016-712	※1 LIN-X450S-1814	1800	10.6~14		1				6214	
		250-016-713	※2 LIN-X450S-1817		14.1~17		2				6916	
		250-016-715	LIN-X450S-2107		Max. 7	3					5648	
		250-016-716	LIN-X450S-2110	1801~	7.1~10.5			LIN-X45-L1740			5648	
		250-016-717	※1 LIN-X450S-2114	2100	10.6~14		1				6350	
		250-016-718	※2 LIN-X450S-2117		14.1~17		2				7052	
		250-016-721	※1 LIN-X450S-2407		Max. 7						6669	
		250-016-722	※1 LIN-X450S-2410	2101~	7.1~10.5		1	LIN-X45-L2040			6669	
		250-016-723	※1 LIN-X450S-2414	2400	10.6~14						6669	
		250-016-724	※2 LIN-X450S-2417		14.1~17		2				-	

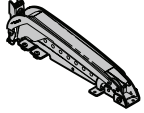
※1: 4 hinges per door. If installing hinge set (without catch & damper) **2**, please use it as the second one from the bottom.  
 ※2: 5 hinges per door. If installing hinge set (without catch & damper) **2**, please use it as the second and third ones from the bottom.

[Parts Set Details] Refer to page **2** for the dimensions.

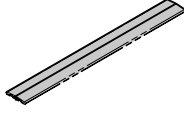
No.	Part Name	Description
<b>1</b>	<b>Hinge Set (With Catch &amp; Damper)</b>	Parts Included in 1 Set Hinge Body (With Catch & Damper)  × 1 Hole Cover  × 1 Binding Head Tapping Screw  × 4 ● Material Steel ● Finish Nickel
	Item Code : 250-016-240 Item Name : LIN-X450ACD Weight (g) : 766	
<b>2</b>	<b>Hinge Set (Without Catch &amp; Damper)</b>	Parts Included in 1 Set Hinge Body (With Catch & Damper)  × 1 Hole Cover  × 1 Binding Head Tapping Screw  × 4 ● Material Steel ● Finish Nickel
	Item Code : 250-016-242 Item Name : LIN-X450A Weight (g) : 702	

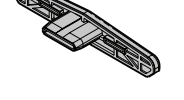
No.	Part Name	Description
<b>3</b>	<b>Connecting Bar</b>	Item Code : 250-016-250 Item Name : LIN-X45-L540 Weight (g) : 481 
		Item Code : 250-016-252 Item Name : LIN-X45-L840 Weight (g) : 647 
		Item Code : 250-016-254 Item Name : LIN-X45-L1140 Weight (g) : 870 
		Item Code : 250-016-255 Item Name : LIN-X45-L1440 Weight (g) : 1200 
<b>4</b>	<b>End Cap for Connecting Bar</b>	Item Code : 250-016-256 Item Name : LIN-X45-L1740 Weight (g) : 1336 ● Material Aluminium Alloy ● Finish Anodised
		Item Code : 250-016-259 Item Name : LIN-X45-L2040 Weight (g) : 1655 ● Material POM ● Colour Grey

Refer to **1** : P.807, **2** : P.805

## Mounting Plate

### Necessary Parts

Mounting Plate **5** : Same qty as hinge (**1** + **2**) is necessary.

Countersunk Head Tapping Screw **6** : 3 pcs are necessary per 1 mounting plate.

No.	RoHS	CAD	Item Code	Dimensions
<b>5</b>			160-070-041	Mounting Plate
Item Name : 230-P4W-32T Weight (g) : 26				
● Material Steel ● Finish Nickel				

No.	RoHS	CAD	Item Code	Dimensions
<b>6</b>			160-070-030	Raised Countersunk Head Tapping Screw 3.5×15
Item Name : TAP3515NI Weight (g) : 1				
● Material Steel ● Finish Nickel				For Mounting Plate

The circled numbers are part numbers. Please check with the parts list **1**. For LIN-X600, refer to **2**.

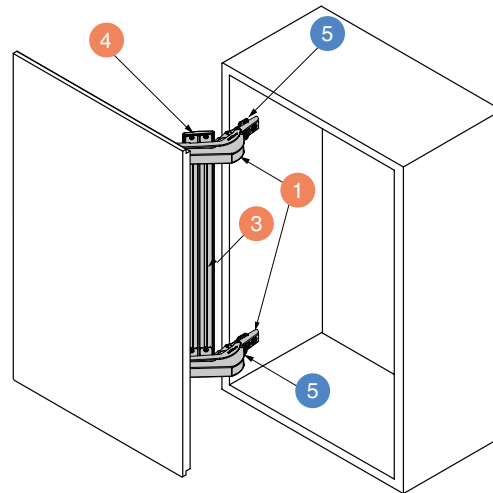

Refer to **1** : P.806~P.807, **2** : P.810

## STANDARD KIT With Mounting Plate



- Includes parts set and mounting plates.
- Suitable for door size (width 400~500mm, height 600~900mm, thickness 15~24mm) and door weight 7kg or less.

### [Parts Included]

Hinge body .....	2 pcs	End cap for connecting bar .....	2 pcs
Mounting plate .....	2 pcs	Hole cover .....	2 pcs
Connecting bar .....	1 pc		
Raised countersunk head tapping screw 3.5×15 .....	6 pcs		
Binding head tapping screw 3.5×15 .....	8 pcs		

RoHS	CAD	Item Code	Item Name	Overlay mm	Door Height mm	Door Weight kg	Mounting Plate (Included)	Weight (g)	Box (sets)	Carton (sets)
		250-014-240	LIN-X450	19	600~900	Max. 7	230-P4W-32T	2162	1	6
		250-014-553	LIN-X450 + 5	14			230-P4W-32T+5	2200	1	6

**LIN-X600 Installation Example**

Door specifications [Width: 550-650 mm] [Thickness: 15-24 mm] [Height: 600-2400 mm] [Weight: Max. 24 kg/door] [Overlay: 19 mm for standard type]

The circled numbers are part numbers. Please check with the parts list 1. For LIN-X450, refer to 2.

**[Locus Chart]**

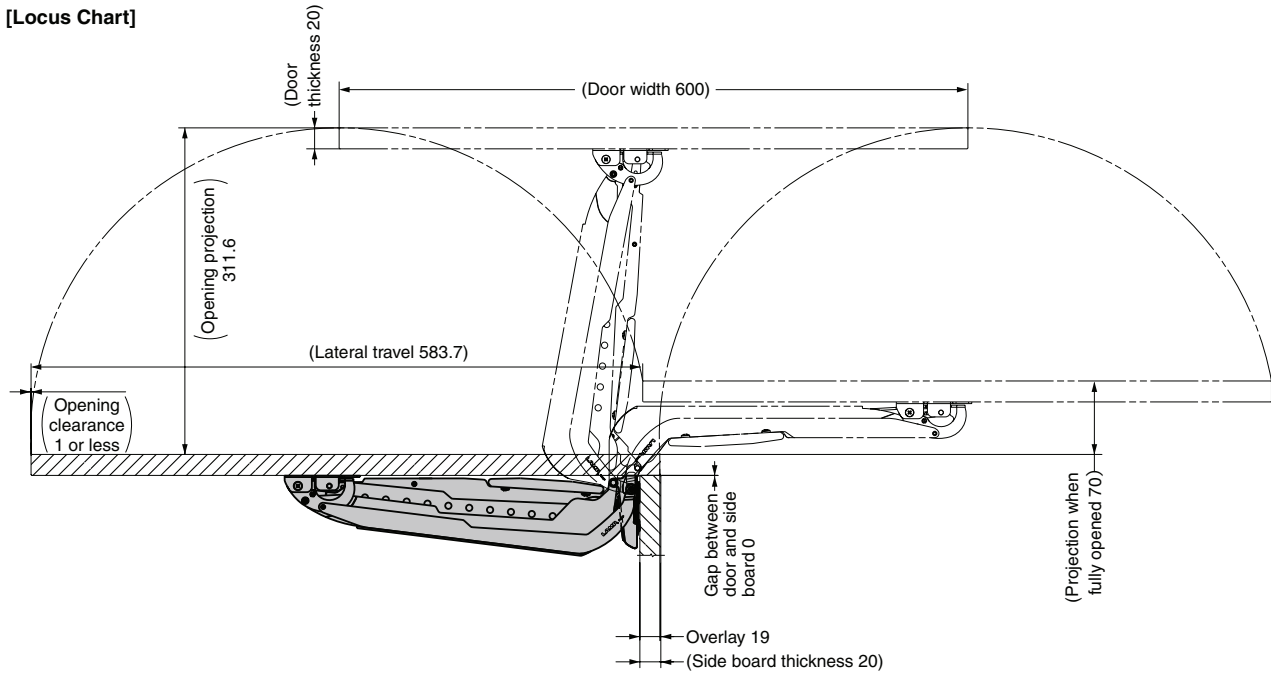

**[Installation]**

● When installing hinge

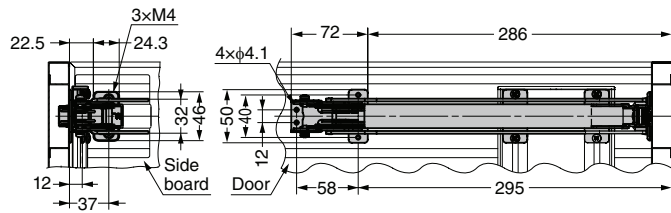

● Before installing hinge

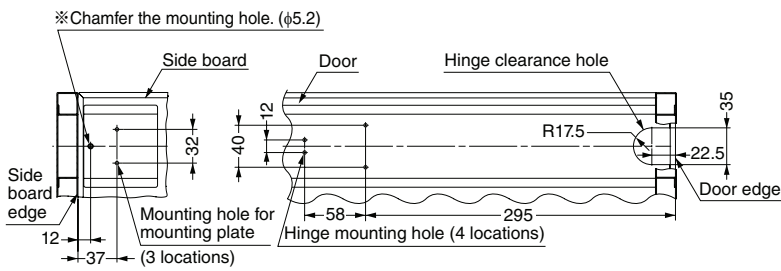

**[Installation Pitch]**

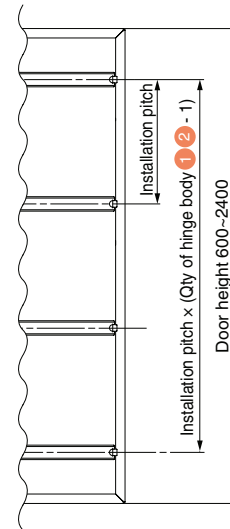

Qty of hinge bodies (1+2)	Item Name Suffix of Parts Set					
	09XX	12XX	15XX	18XX	21XX	24XX
	Connecting Bar (3) Length L					
2 Hinges per Door	540	840	1140	1440	1740	2040
3 Hinges per Door	490	790	—	—	—	—
4 Hinges per Door	245	395	545	695	845	—
5 Hinges per Door	—	—	363	463	563	663
5 Hinges per Door	—	—	—	347.5	422.5	497.5

Refer to 1 : P.810, 2 : P.806

[Parts Drawings]

- Hinge body  
When closed

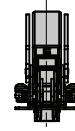
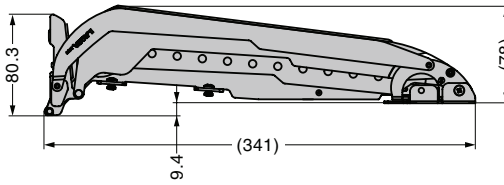
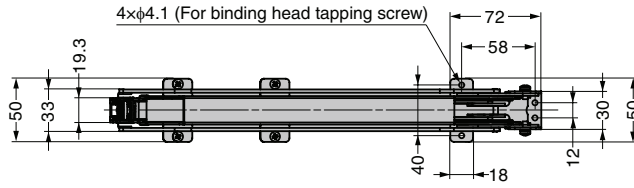

When opened

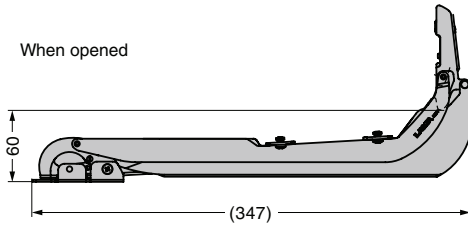

- Hole cover

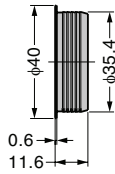
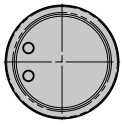

- Connecting bar

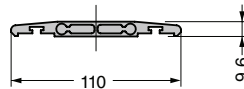
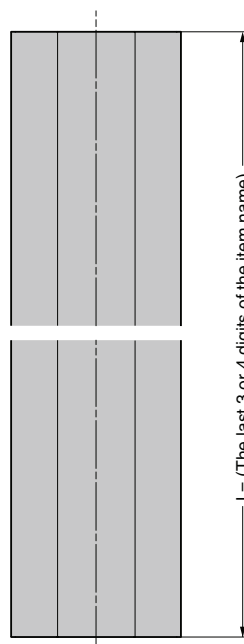

- End cap for connecting bar

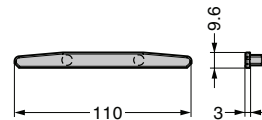

## When Ordering MonoFlat LIN-X Hinge LIN-X600

● Necessary Parts..... **Parts Set (Per Door)** + **Mounting Plate**







● Standard kit **1** including mounting plates also available, suitable for door height 600~900mm and door weight 9kg or less.

		Parts Set (Per Door)		Necessary Parts.							
				Choose based on applicable door height and door weight. (Refer to <b>2</b> for details on dimensions and descriptions of parts included in the set.)							
RoHS	CAD	Item Code	Item Name	Door Height mm	Door Weight kg	Parts Included (For LIN-X600)				Weight (g)	
						① Hinge Set (With Catch & Damper)	② Hinge Set (Without Catch & Damper)	③ Connecting Bar	④ End Cap For Connecting Bar		
						Qty/set	Qty/set	Qty/pc	Qty/pc		
		250-017-492	LIN-X600S-0909	600~	Max. 9	2					4913
		250-017-067	LIN-X600S-0912	900	9.1~12	3					5930
		250-017-068	LIN-X600S-1212	901~	Max. 12	2					5232
		250-017-069	LIN-X600S-1216	1200	12.1~16		—				6270
		250-017-070	LIN-X600S-1512	1201~ 1500	Max. 12						6752
		250-017-071	LIN-X600S-1516		12.1~16						6752
		250-017-072	※1 LIN-X600S-1520		16.1~20		1				7748
		250-017-073	LIN-X600S-1812	1501~ 1800	Max. 12						7070
		250-017-074	LIN-X600S-1816		12.1~16						7070
		250-017-075	※1 LIN-X600S-1820		16.1~20		1	1	2		8066
		250-017-493	※2 LIN-X600S-1824		20.1~24	3	2				9062
		250-017-076	LIN-X600S-2112	1801~ 2100	Max. 12						7608
		250-017-077	LIN-X600S-2116		12.1~16						7608
		250-017-078	※1 LIN-X600S-2120		16.1~20		1				8604
		250-017-079	※2 LIN-X600S-2124		20.1~24		2				9600
		250-017-080	※1 LIN-X600S-2412	2101~ 2400	Max. 12						9066
		250-017-081	※1 LIN-X600S-2416		12.1~16			1			9066
		250-017-082	※1 LIN-X600S-2420		16.1~20						9066
		250-017-083	※2 LIN-X600S-2424		20.1~24		2				9066













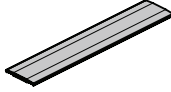

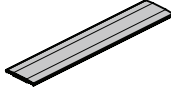
※1: 4 hinges per door. If installing hinge set (without catch & damper) ②, please use it as the second one from the bottom.

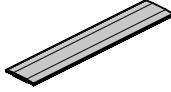
※2: 5 hinges per door. If installing hinge set (without catch & damper) ②, please use it as the second and third ones from the bottom.

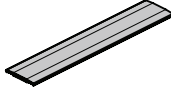
[Parts Set Details] Refer to page **2** for the dimensions.

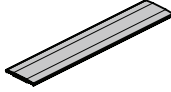
No.	Part Name	Description
①	<b>Hinge Set (With Catch &amp; Damper)</b> Parts Included in 1 Set Hinge Body (With Catch & Damper)	Item Code :   250-016-962 Item Name : LIN-X600ACD Weight (g) : 1017
	 ×1	
	Hole Cover ×1	
	Binding Head Tapping Screw ×4	● Material Steel ● Finish Nickel
②	<b>Hinge Set (Without Catch &amp; Damper)</b> Parts Included in 1 Set Hinge Body (Without Catch & Damper)	Item Code :   250-016-963 Item Name : LIN-X600A Weight (g) : 996
	 ×1	
	Hole Cover ×1	
	Binding Head Tapping Screw ×4	● Material Steel ● Finish Nickel

Refer to **1** : P.811, **2** : P.808~P.809

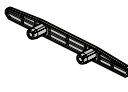
No.	Part Name	Description
③	<b>Connecting Bar</b>	Item Code :   250-016-964 Item Name : LIN-X60-L540 Weight (g) : 860
		Item Code :   250-016-965 Item Name : LIN-X60-L840 Weight (g) : 1200
		Item Code :   250-016-966 Item Name : LIN-X60-L1140 Weight (g) : 1682
		Item Code :   250-016-967 Item Name : LIN-X60-L1440 Weight (g) : 2000
		Item Code :   250-016-968 Item Name : LIN-X60-L1740 Weight (g) : 2538
		Item Code :   250-016-969 Item Name : LIN-X60-L2040 Weight (g) : 3000
		● Material Aluminium Alloy ● Finish Anodised
④	<b>End Cap for Connecting Bar</b>	Item Code :   250-016-970 Item Name : LIN-X60C Weight (g) : 4
		● Material POM ● Colour Grey

## Mounting Plate

### Necessary Parts.

Mounting Plate **5** : Same qty as hinge (**1** + **2**) is necessary.

Countersunk Head Tapping Screw **6** : 3 pcs are necessary per 1 mounting plate.

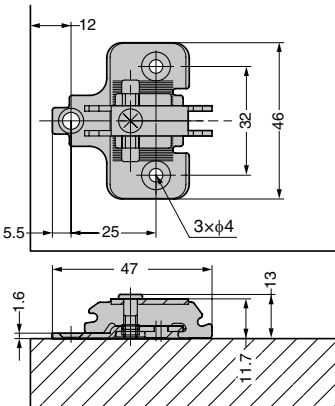
No.	RoHS	CAD	Item Code	Dimensions
<b>5</b>			160-070-041	Mounting Plate
Item Name : 230-P4W-32T Weight (g) : 26				
				
				
● Material Steel ● Finish Nickel				

No.	RoHS	CAD	Item Code	Dimensions
<b>6</b>			160-070-030	Raised Countersunk Head Tapping Screw 3.5×15
Item Name : TAP3515NI Weight (g) : 1				
				
For Mounting Plate				
● Material Steel ● Finish Nickel				

The circled numbers are part numbers. Please check with the parts list **1**. For LIN-X450, refer to **2**.

4 hinges per door shown.

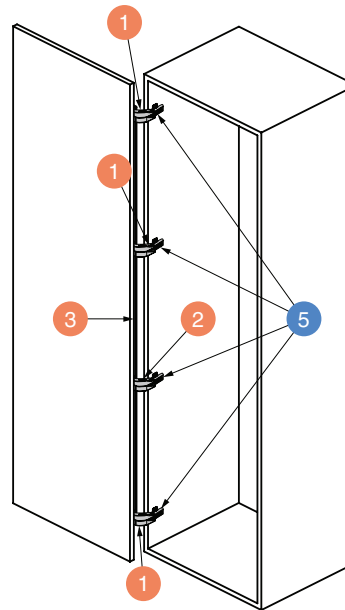

Refer to **1** : P.810~P.811, **2** : P.806

## STANDARD KIT With Mounting Plate

### [Parts Included]

Hinge body ..... 2 pcs      End cap for connecting bar ..... 2 pcs  
 Mounting plate ..... 2 pcs      Hole cover ..... 2 pcs  
 Connecting bar ..... 1 pc  
 Raised countersunk head tapping screw 3.5×15 ..... 6 pcs  
 Binding head tapping screw 3.5×15 ..... 8 pcs

● Includes parts set and mounting plates.

● Suitable for door size (width 550~650mm, height 600~900mm, thickness 15~24mm) and door weight 9kg or less.

RoHS	CAD	Item Code	Item Name	Overlay mm	Door Height mm	Door Weight kg	Mounting Plate (Included)	Weight (g)	Box (sets)	Carton (sets)
		250-017-590	LIN-X600	19	600~900	Max. 9	230-P4W-32T	3210	1	4

## MONOFLAT LIN-X HINGE LIN-X800

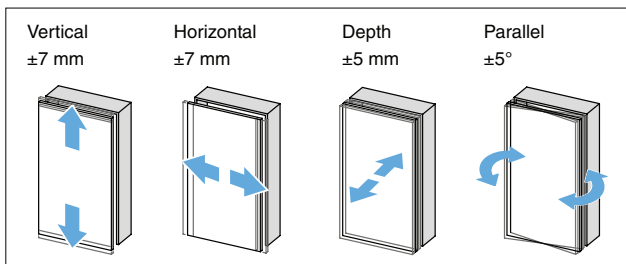
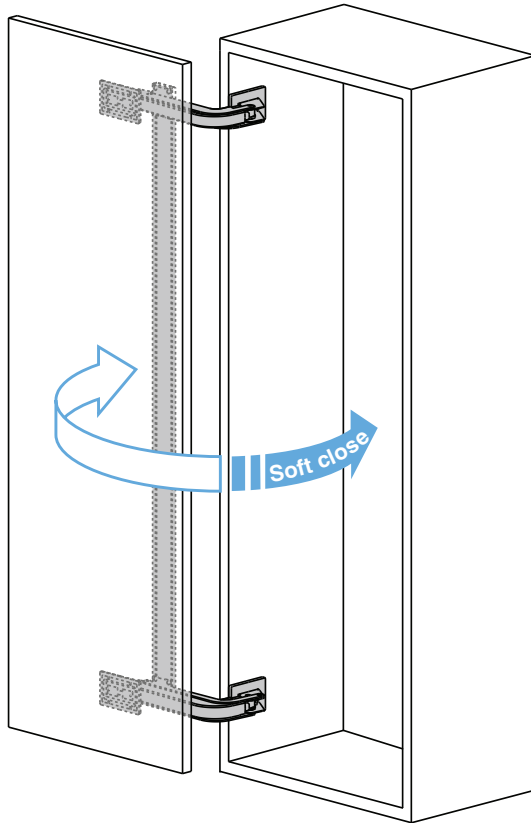
Passed 100,000 open/  
close private cycle test

\*Vertical, Horizontal, Depth and Parallel adjustment possible post-installation.

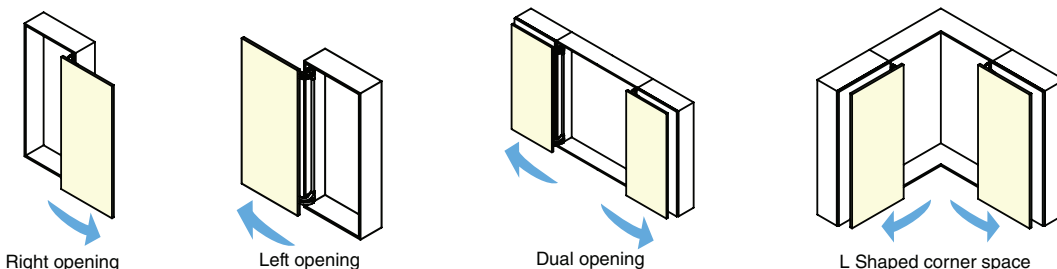

INSTRUCTION

## MonoFlat LIN-X hinge®

	LIN-X800	LIN-X800H
Door Width	750 - 850 mm	
Door Height	1600※ - 2400 mm	1600※ - 2980 mm
Door Thickness	24 - 40 mm	
Door Weight	Max. 40 kg per door	
Usage	1 per door (Overlay)	

※ Please use by cutting the connecting rod.

For details, refer to the formula in the detailed drawing on P.813.

- **Innovative movement keeps doors discretely out of the way.**  
Door closes flush with surrounding walls for a sleek and clean design.  
No need to do special processing on any wall for grooves or rails.  
Can be used on aluminium frames (if the frame has a thickness over 120 mm).
- **Whether open or closed, door stays out of the way**  
Compared to regular swing doors, has a small radius allowing the space in front of the door to be used effectively.
- **Opens fully for access to entire cabinet.**  
Whether installing cabinets or just getting access, the entire cabinet interior is easily accessible.
- **Built-in soft close mechanism**  
When the door closes, the internal damper will cause the door to close softly, preventing slamming.
- **4 Way adjustment post installation**  
Can be adjusted vertically, horizontally, depth or parallel.
- **Wide amount of applicable cabinets**  
Can be used on dual opening, single opening cabinets. Can also be used on L shaped corner spaces.

## [Parts Included]

- OTruss head tapping screw 6\*25
- Truss head screw M5 × 10
- M5 Square Nut
- One end mouth wrench

## [Colour Variation]



Black



White

Video Link



**MONO FLAT LIN-X HINGE**







If ordering LIN-X800

• Be sure to order..... **Part Set (per door)**

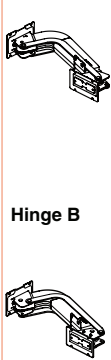
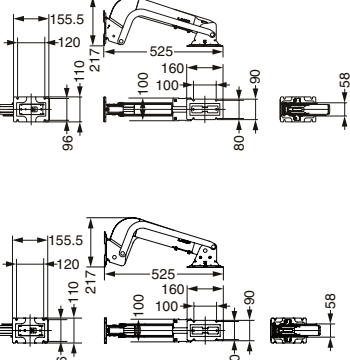
**Part Set (per door)** This set must be ordered. Select a suitable set according to the door height.

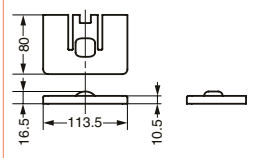
RoHS	CAD	Item Code	Item Name	Door Height	Colour	Set Content (for LIN-X800)			
						1 Hinge + 2 Washer Cover + 4 Rod Cover		5 Connecting Rod	
						Item Code	Item Name	Item Code	Item Name
CE	3D	250-043-897	LIN-X800-BL-S	2400 mm	Black	250-043-834	LIN-X800-BL	250-043-842	LIN-X80-L2100-BL
CE	3D	250-043-898	LIN-X800-WT-S	or Less	White	250-043-835	LIN-X800-WT	250-043-843	LIN-X80-L2100-SL
CE	3D	250-043-899	LIN-X800H-BL-S	2980 mm	Black	250-043-834	LIN-X800-BL	250-043-844	LIN-X80-L2500-BL
CE	3D	250-043-900	LIN-X800H-WT-S	or Less	White	250-043-835	LIN-X800-WT	250-043-845	LIN-X80-L2500-SL

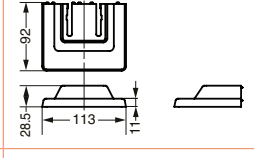
**Part Set Contents**

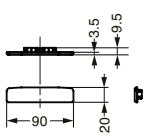
No.	Quantity	Parts in Set	Dimensions	Specifications
1	A - B 1 each	 <p><b>Hinge A</b> <b>Hinge B</b></p>		<ul style="list-style-type: none"> <li>Material: Steel (SPCC)/ Polyacetal (POM)</li> <li>Finish: Nickel Plating Baked enamel finish</li> </ul>
2	4 pcs	Washer cover (hanging side)	 	Material: ABS resin
3	4 pcs	Washer cover (leading edge)	 	Material: ABS resin
4	2 pcs	Rod cover	 	Material: Polyacetal (POM)

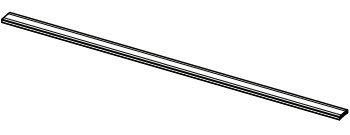
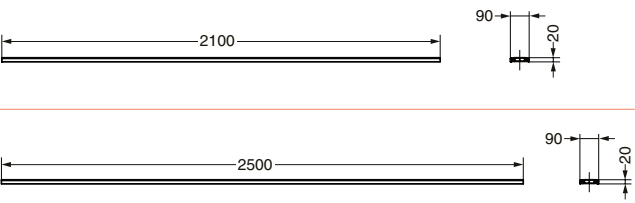
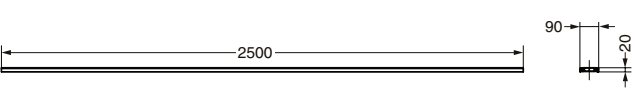
No.	Quantity	Parts in Set	Dimensions	Specifications
5	Either part	Connecting rod	 	<ul style="list-style-type: none"> <li>Material: Aluminium alloy</li> <li>Finish: Anodised: Black/silver</li> </ul>
				<ul style="list-style-type: none"> <li>Material: Aluminium alloy</li> <li>Finish: Anodised: Black/silver</li> </ul>

**Detailed Drawing**

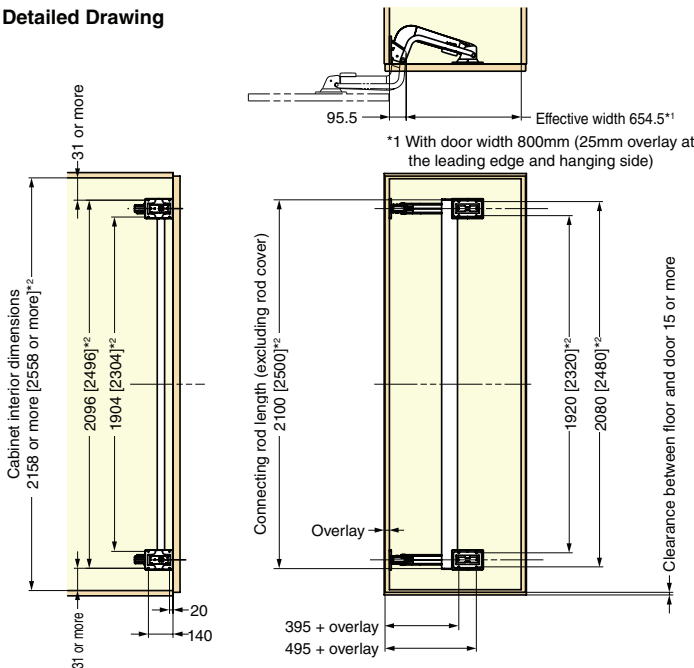

**Range of Motion**

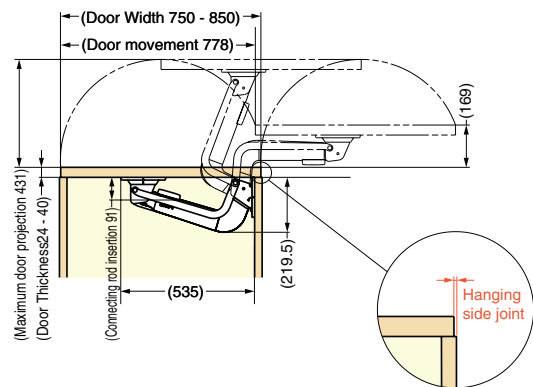

\*2 The dimensions in [ ] indicate LIN-X800H specifications.  
 \*2 For cabinet interior dimensions smaller than the minimum value, reduce the other dimensions marked with \*2 by an equivalent amount. The connecting rod must be cut by the customer. Max length of connecting rod = Cabinet inner height - 58mm.

# MONOFLAT LIN-X HINGE LIN-X1000 For Heavy Duty Door

INSTRUCTION



## MonoFlat LIN-X hinge®

	LIN-X1000 For Heavy Duty
Door Width	750~1100 mm
Door Height	2400※ <sup>1</sup> ~2980 mm
Door Thickness	24~40 mm
Door Weight	Max. 90 kg/Door ※ <sup>2</sup>
Overlay	19 mm
Specification	<input type="checkbox"/> Single Door (Overlay)

※<sup>1</sup> Height may be 2400mm or less if cutting the connecting bar. For further details, please contact local representatives.  
 ※<sup>2</sup> Set the clearance between floor and door according to door weight. For details, refer to the drawings on P.815.



### POINT 1

#### Max. door width 1100mm (effective opening width 930 mm)

Installed to side wall, not interfering with taking in/out of articles.

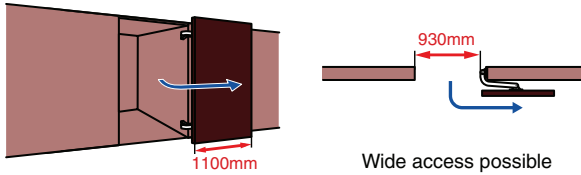

### POINT 2

#### Max. door weight 90kg



Recommended for storage doors and walk-in closets.

### POINT 3

#### Door does not get in the way when opening and closing.

Opening projection is about half of swing door. Door will be flush with surrounding walls when closed.

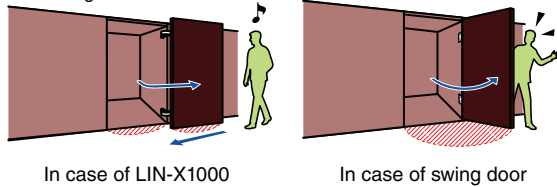

### POINT 4

#### Greatly shortened installation time

Sub-arm is unnecessary at the upper/lower part of door, remarkably shortening installation time.

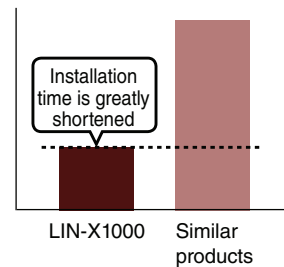

### Other Features



Door closes smoothly and softly with damper. (Damping force 5-step adjustable)

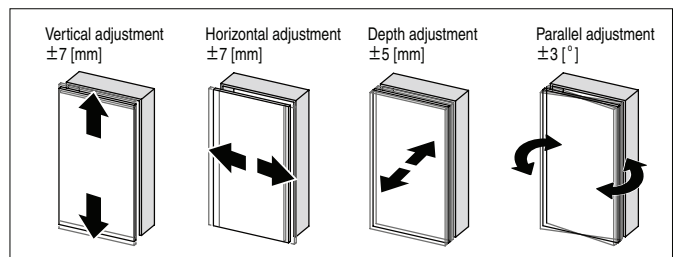

● Adjustable in vertical, horizontal, depth and parallel directions.

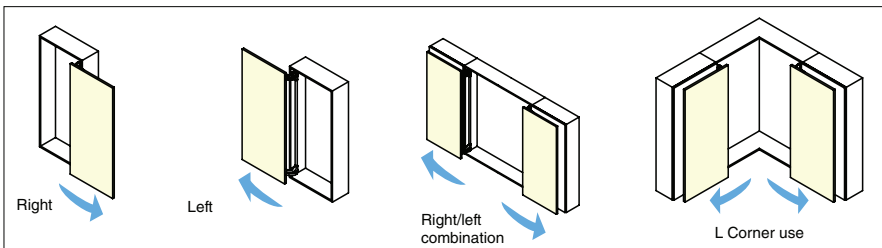

● Suitable for various cabinets.



● Available in white and black colours.

When ordering MonoFlat  
LIN-X Hinge LIN-X1000  
For Heavy Duty Door

● Necessary Parts..... **Parts Set (Per Door)** + **Connecting Bar**

The circled numbers are part numbers. Please check with the drawings on the bottom.

Parts Set (Per Door)

Necessary Parts.

Set Name	RoHS	CAD	Item Code	Item Name	Weight (g)
Parts Set			250-034-706	LIN-X1000-WT	12000
			250-042-288	LIN-X1000-BL	12000

Parts Included

No.	Qty	Dimensions	Description
1	1 pc		Arm A ● Material Aluminium Alloy Die-casting ● Finish Powder Coating/ White/Black
2	1 pc		Arm B ● Material Aluminium Alloy Die-casting ● Finish Powder Coating/ White/Black
3	4 pcs		Cover for Mounting Plate (Hinge Side) ● Material ABS ● Colour White/Black
4	4 pcs		Cover for Mounting Plate (Door Side) ● Material ABS ● Colour White/Black
5	1 pc		Damper for Opening ● Material PBT ● Colour White/Black

Connecting Bar

Necessary Parts 1 pc is necessary for 1 door.

No.	Qty	RoHS	CAD	Item Code	Dimensions	Description
6	1 pc			250-034-707		● Item Name: LIN-X100-L2000-WT ● Weight (g) : 3300
				250-042-289		● Item Name: LIN-X100-L2000-BL ● Weight (g) : 3300

Table 1: Handle position area

Hinge side clearance	10mm	15mm	20mm
Door width 750mm~ 900mm	Max. 300mm	Max. 350mm	Max. 500mm
900mm~1000mm	Max. 200mm	Max. 250mm	Max. 400mm
1000mm~1100mm	Max. 100mm	Max. 150mm	Max. 300mm

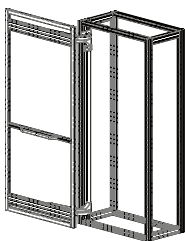

[Installation Example]

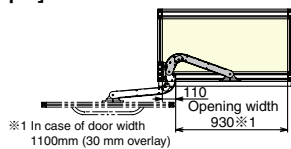

[Locus Chart]

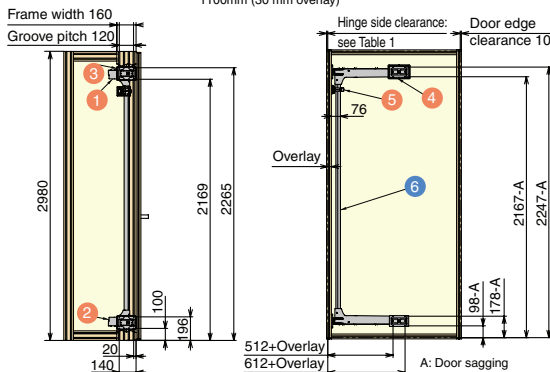
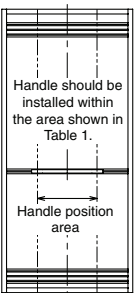
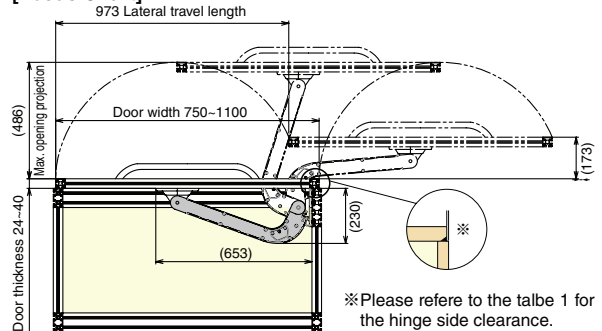

Please set door sagging A based on the following table so that the door will not contact the floor.

Door weight	A: Door sagging
20kg	2mm
30kg	3.5mm
40kg	5mm
50kg	6.5mm
60kg	8mm
70kg	9.5mm
80kg	11mm
90kg	12.5mm

- For carpeted floor, add the carpet thickness to the "door sagging" shown above.
- This product is vertically adjustable by ± 7mm after installation. For adjustment method, please refer to the installation instruction.