



V7 Draw Latch

Over-center · Large · Stainless steel

- Sleek, smooth low profile design
- Locking and non-locking
- Robust, riveted, tamper-resistant construction

Material and Finish

316 Grade stainless steel
electropolished

Performance Details

Max. working load: 1200 N (270 lbf)

Installation Notes

Install assembly with six M3 (No. 4)
flat head screws (not supplied)

Keys

Overmolded key S008 (pair)
Part number: M1-525-39-S008

Latch

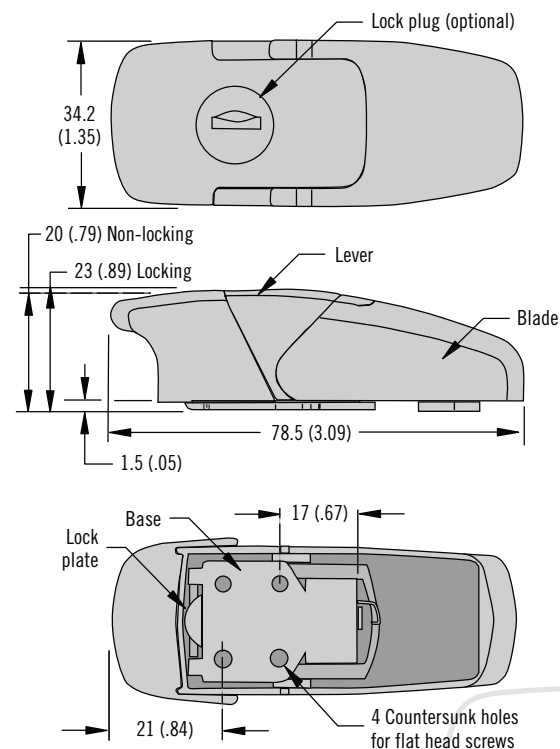

Keeper

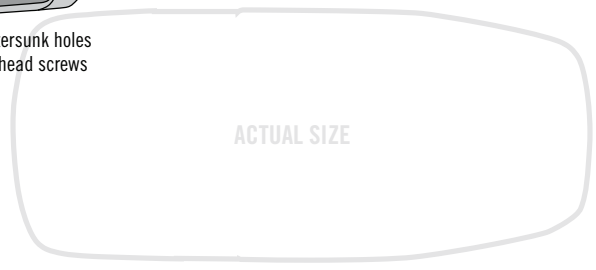
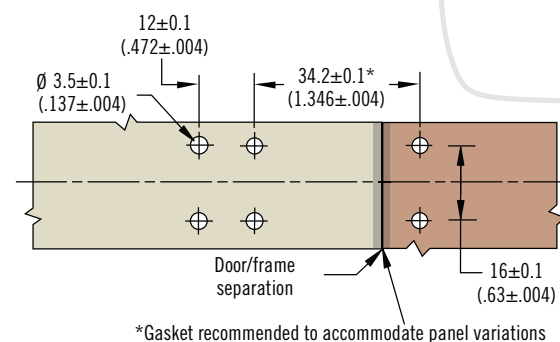
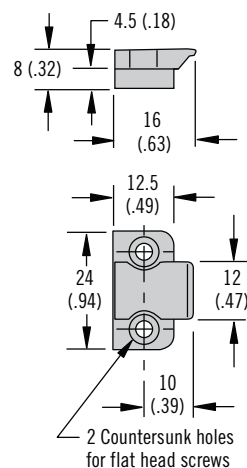

Part Number

See table

Assembly complete with keeper

Description	Part Number
Non-locking	V7-20-101-24
Locking keyed alike S008 (2 keys supplied)	V7-20-111-24