



ST-8A Hinge

Position control · Constant torque

- Holds in every position
- No adjustment required
- Long cycle life

Material and Finish

Zinc alloy, black paint

Performance Details

Cycle performance
20,000 cycles within ±20% of static torque specification

Installation Notes

Thread stud install with M3 nuts (not supplied)

Thru hole install with M3 (No. 4) screws (not supplied)

To ensure proper function, assembly must include a minimum of one Type A and one Type B hinge

Part Number

See table

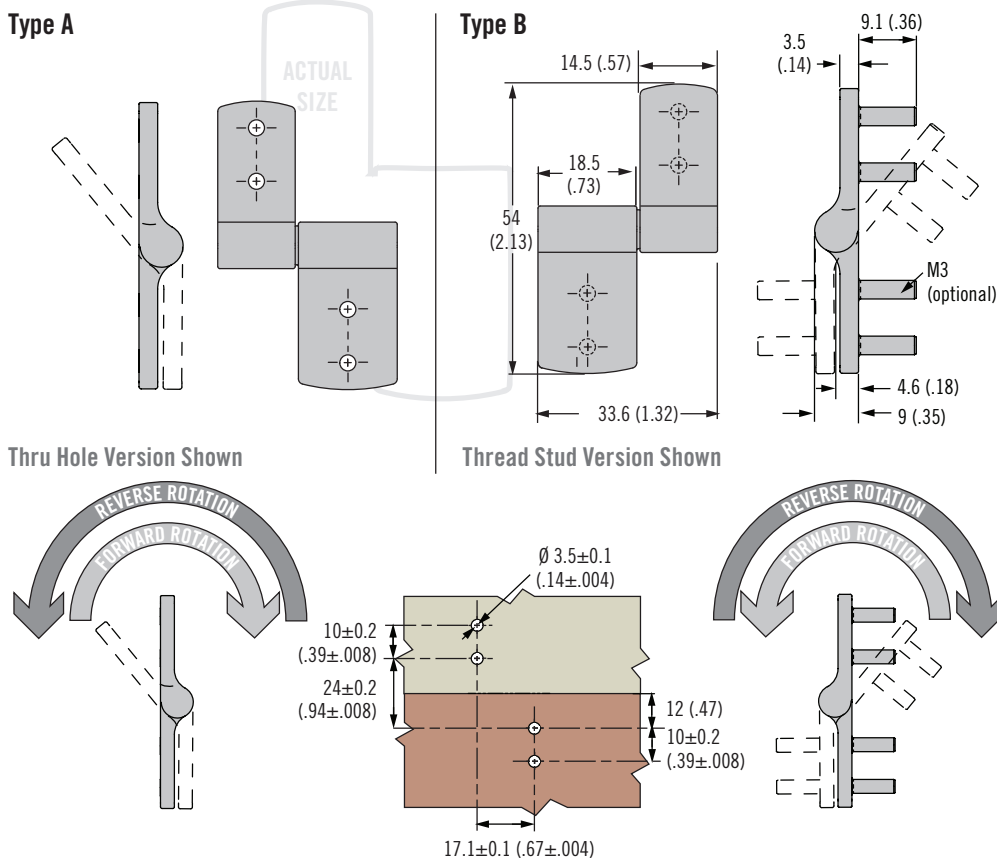

Symmetric Torque Version				
Part Number				Static Torque (forward and reverse) N·m (in·lbf)
M3 Thread Stud		Thru Hole		
Type A	Type B	Type A	Type B	
ST-8A1-40SA-50	ST-8A1-40SB-50	ST-8A-40SA-50	ST-8A-40SB-50	0.45 (4)
ST-8A1-60SA-50	ST-8A1-60SB-50	ST-8A-60SA-50	ST-8A-60SB-50	0.68 (6)
ST-8A1-80SA-50	ST-8A1-80SB-50	ST-8A-80SA-50	ST-8A-80SB-50	0.9 (8)

Asymmetric Torque Version					
Part Number				Forward Torque N·m (in·lbf)	Reverse Torque N·m (in·lbf)
M3 Thread Stud		Thru Hole			
Type A	Type B	Type A	Type B		
ST-8A1-40FA-50	ST-8A1-40FB-50	ST-8A-40FA-50	ST-8A-40FB-50	0.45 (4)	0.27 (2.4)
ST-8A1-60FA-50	ST-8A1-60FB-50	ST-8A-60FA-50	ST-8A-60FB-50	0.68 (6)	0.41 (3.6)
ST-8A1-80FA-50	ST-8A1-80FB-50	ST-8A-80FA-50	ST-8A-80FB-50	0.90 (8)	0.54 (4.8)
ST-8A1-100FA-50	ST-8A1-100FB-50	ST-8A-100FA-50	ST-8A-100FB-50	1.13 (10)	0.68 (6)
ST-8A1-40RA-50	ST-8A1-40RB-50	ST-8A-40RA-50	ST-8A-40RB-50	0.27 (2.4)	0.45 (4)
ST-8A1-60RA-50	ST-8A1-60RB-50	ST-8A-60RA-50	ST-8A-60RB-50	0.41 (3.6)	0.68 (6)
ST-8A1-80RA-50	ST-8A1-80RB-50	ST-8A-80RA-50	ST-8A-80RB-50	0.54 (4.8)	0.9 (8)
ST-8A1-100RA-50	ST-8A1-100RB-50	ST-8A-100RA-50	ST-8A-100RB-50	0.68 (6)	1.13 (10)

ST-11A Hinge

Position control · Constant torque

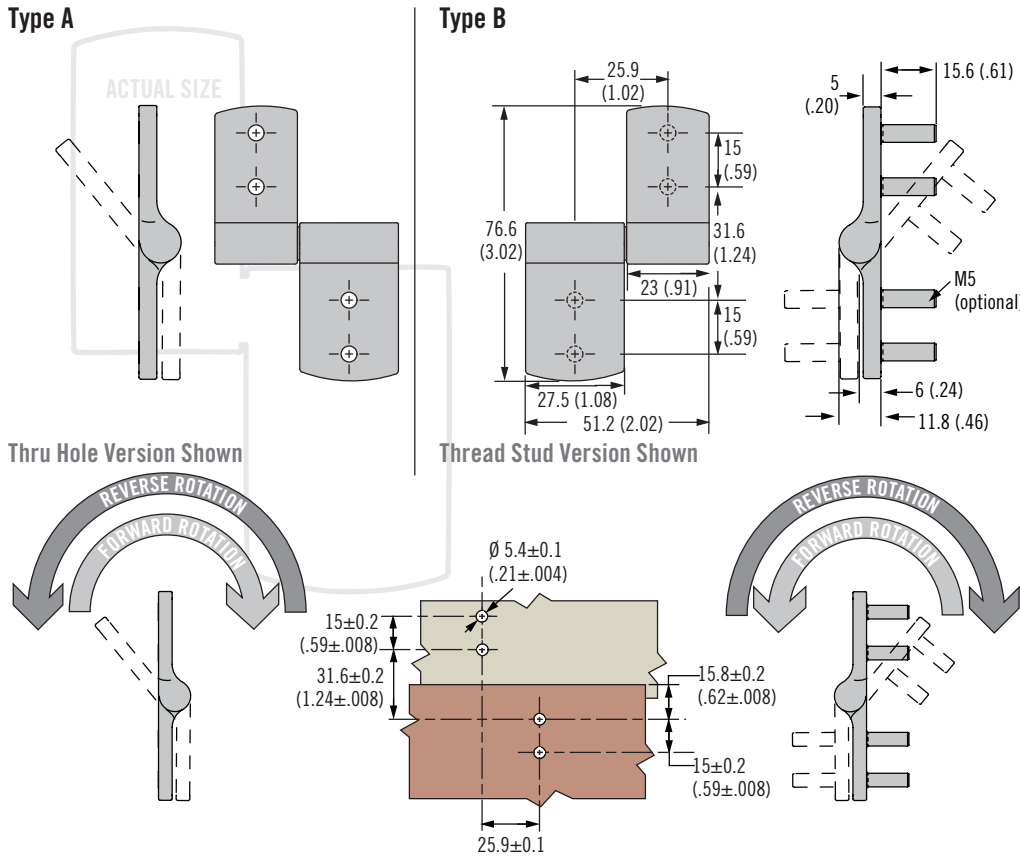

- Holds in every position
- No adjustment required
- Long cycle life

Material and Finish

Zinc alloy, black paint

Performance Details

Cycle performance
20,000 cycles within ±20% of static torque specification

Installation Notes

Thread stud install with M5 nuts (not supplied)

Thru hole install with M5 (No. 10) screws (not supplied)

To ensure proper function, assembly must include a minimum of one Type A and one Type B hinge

Part Number

See table

Symmetric Torque Version				
Part Number				Static Torque (forward and reverse) N·m (in·lbf)
M5 Thread Stud		Thru Hole		
Type A	Type B	Type A	Type B	
ST-11A1-140SA-50	ST-11A1-140SB-50	ST-11A-140SA-50	ST-11A-140SB-50	1.58 (14)
ST-11A1-200SA-50	ST-11A1-200SB-50	ST-11A-200SA-50	ST-11A-200SB-50	2.26 (20)
ST-11A1-260SA-50	ST-11A1-260SB-50	ST-11A-260SA-50	ST-11A-260SB-50	2.94 (26)

Asymmetric Torque Version					
Part Number				Forward Torque N·m (in·lbf)	Reverse Torque N·m (in·lbf)
M5 Thread Stud		Thru Hole			
Type A	Type B	Type A	Type B		
ST-11A1-140FA-50	ST-11A1-140FB-50	ST-11A-140FA-50	ST-11A-140FB-50	1.58 (14)	0.95 (8.4)
ST-11A1-200FA-50	ST-11A1-200FB-50	ST-11A-200FA-50	ST-11A-200FB-50	2.26 (20)	1.36 (12)
ST-11A1-260FA-50	ST-11A1-260FB-50	ST-11A-260FA-50	ST-11A-260FB-50	2.94 (26)	1.76 (15.6)
ST-11A1-320FA-50	ST-11A1-320FB-50	ST-11A-320FA-50	ST-11A-320FB-50	3.62 (32)	2.17 (19.2)
ST-11A1-140RA-50	ST-11A1-140RB-50	ST-11A-140RA-50	ST-11A-140RB-50	0.95 (8.4)	1.58 (14)
ST-11A1-200RA-50	ST-11A1-200RB-50	ST-11A-200RA-50	ST-11A-200RB-50	1.36 (12)	2.26 (20)
ST-11A1-260RA-50	ST-11A1-260RB-50	ST-11A-260RA-50	ST-11A-260RB-50	1.76 (15.6)	2.94 (26)
ST-11A1-320RA-50	ST-11A1-320RB-50	ST-11A-320RA-50	ST-11A-320RB-50	2.17 (19.2)	3.62 (32)