

REVISION HISTORY			
REV	DATE	BY	DESCRIPTION
A	14JUL2020	JJT/MJS	IP-2020-1763

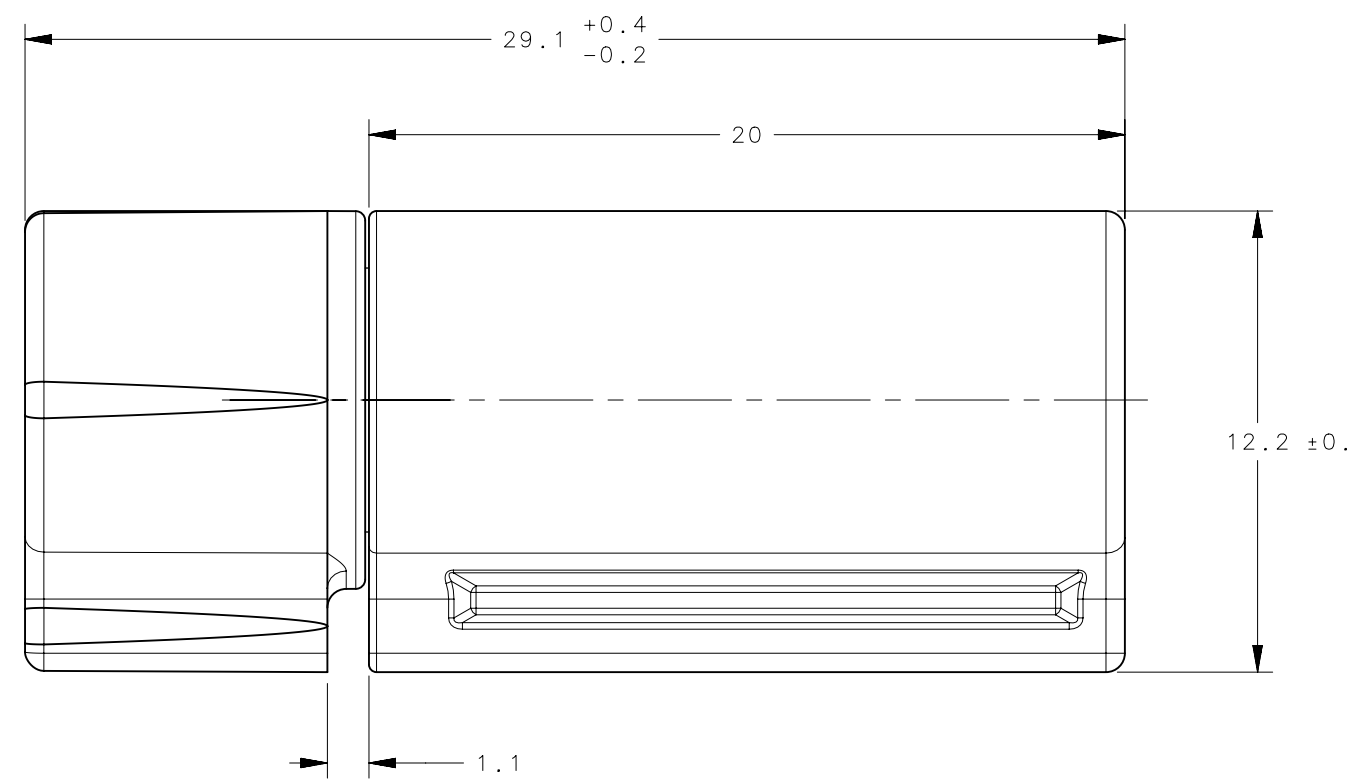
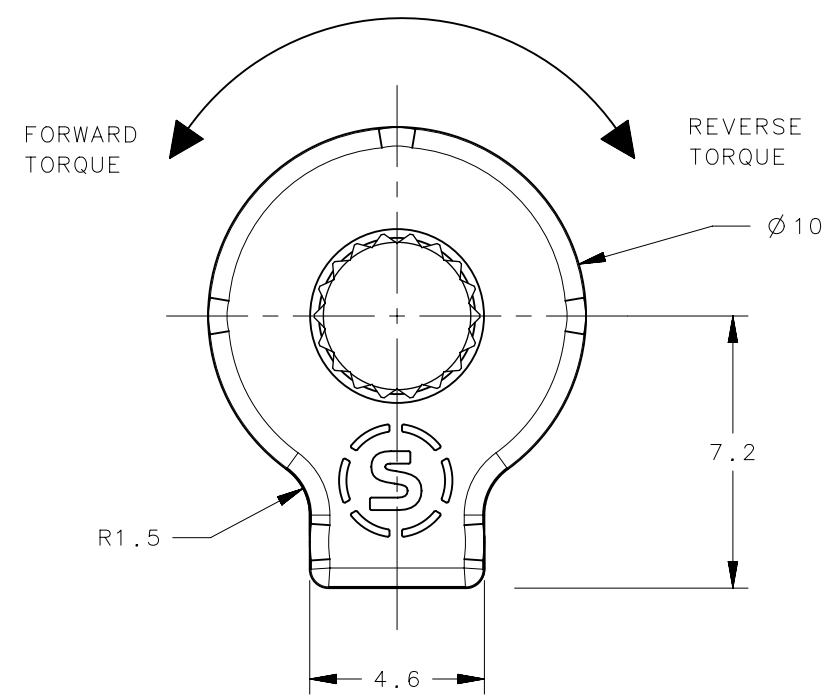
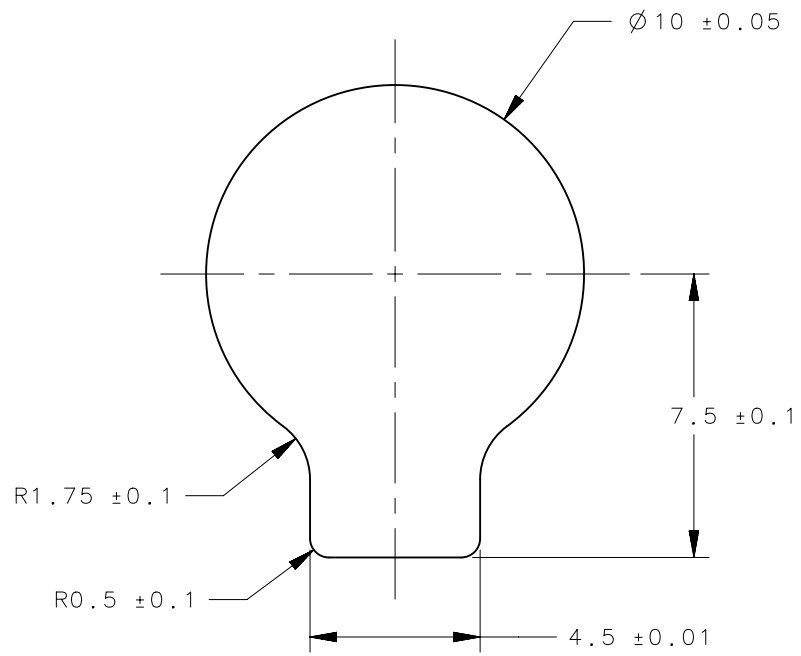

## PANEL PREPARATION

NOTES:

- CYCLE LIFE TO BE 20,000 CYCLES WITH LESS THAN 20% TORQUE CHANGE FROM MANUFACTURED VALUE.
- MATERIAL:
  - HOUSING: DIE CAST ZINC
  - INTERNAL COMPONENTS: HARDENED STEEL
  - BUSHINGS: PLASTIC
- MAX BACKLASH 1° AFTER 20,000 CYCLES
- RECOMMENDED PANEL PREPARATION FOR POLYMERS. FOR APPLICATIONS USING DIFFERENT MATERIALS, CONTACT SOUTHCO.

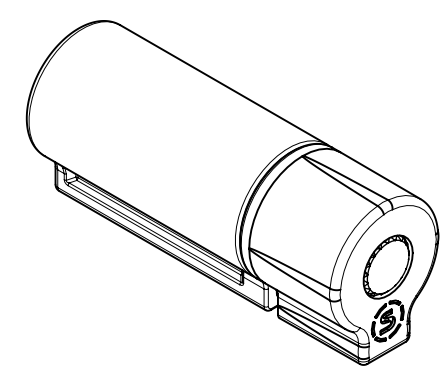

PART NUMBER	FORWARD TORQUE Nm (in-lbf)	REVERSE TORQUE Nm (in-lbf)
ST-10P-140S-33	1.58 (14)	
ST-10P-100S-33	1.13 (10)	
ST-10P-080S-33	0.90 (8)	
ST-10P-040S-33	0.45 (4)	
ST-10P-200F-33	2.26 (20)	1.58 (14) REF
ST-10P-160F-33	1.81 (16)	1.27 (11.2) REF
ST-10P-120F-33	1.36 (12)	0.95 (8.4) REF
ST-10P-080F-33	0.90 (8)	0.63 (5.6) REF
ST-10P-040F-33	0.45 (4)	0.32 (2.8) REF
ST-10P-200R-33	1.58 (14) REF	2.26 (20)
ST-10P-160R-33	1.27 (11.2) REF	1.81 (16)
ST-10P-120R-33	0.95 (8.4) REF	1.36 (12)
ST-10P-080R-33	0.63 (5.6) REF	0.90 (8)
ST-10P-040R-33	0.32 (2.8) REF	0.45 (4)

CPB NUMBER	2019-0401
SURFACE AREA	mm <sup>2</sup>
VOLUME	mm <sup>3</sup>
PROPRIETARY ITEM	
EXCEPT FOR USES EXPRESSLY GRANTED IN WRITING, INFORMATION DISCLOSED HEREON IS CONFIDENTIAL AND ALL RIGHTS, PATENT AND OTHERWISE, ARE RESERVED BY SOUTHCO, INC.	

THIRD ANGLE PROJECTION

MILLIMETERS [IN]

TOLERANCES UNLESS OTHERWISE NOTED

ALL DIMENSIONS WITHOUT TOLERANCES ARE FOR REFERENCE ONLY.

PER ASME Y14.5M-1994

**southco**<sup>®</sup>  
CONNECT • CREATE • INNOVATE

DESCRIPTION: HINGE & CONTROLLED MOTION DEVICE  
PRESS-IN HINGE, CONSTANT TORQUE

SIZE	SYSTEM	DWG NO.
B	NX	J-ST-10P-200

DRAWN BY: JJT    DATE: 03FEB2020    SCALE: 1:1    SHEET: 1 OF 1