

R4 Rotary Latch

Light-Duty · Concealed · Single and two stage

- Compatible with wide array of actuators
- EN 45545-3 E60 Compliant (Standard version only)
- Integrated bumper version for anti-vibration feature

Material and Finish

Steel, zinc plated or 304 stainless steel, passivated

Accessories

Striker bolts for standard version and integrated bumper version are different. See page 297 for both versions.

Cables and retainer clips see pages 322-323

Notes

Electromechanical rotary latch available see page 20

Single Stage - Perpendicular (left hand actuation shown)

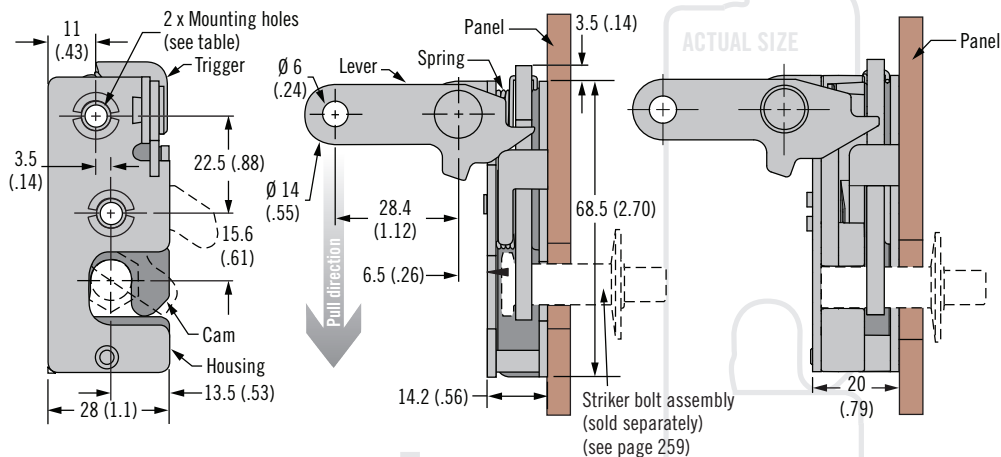

Integrated Bumper Version

(dimensions same as standard version except as shown)

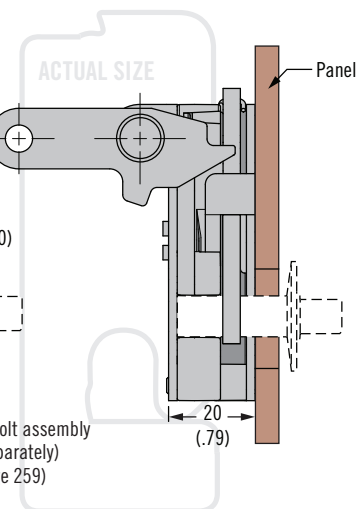

Single Stage - In-Line (left hand actuation shown)

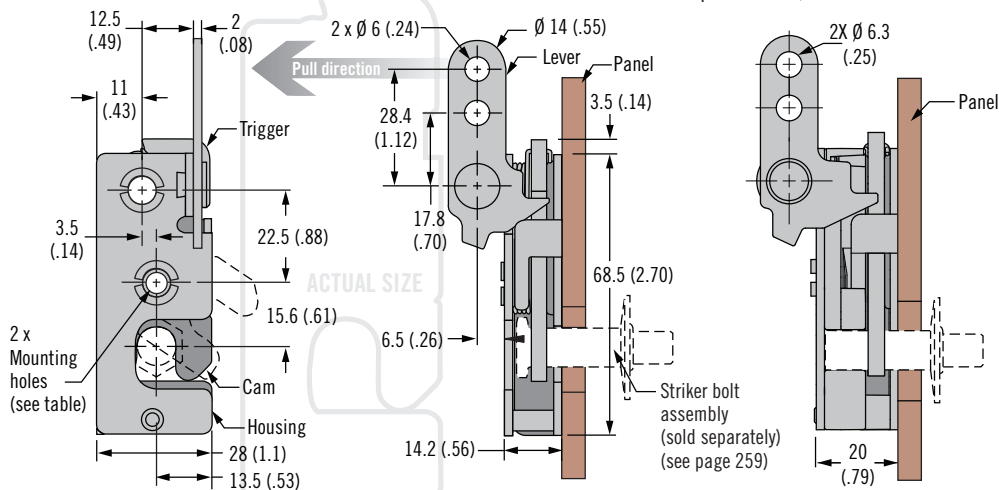

Integrated Bumper Version

(dimensions same as standard version except as shown)

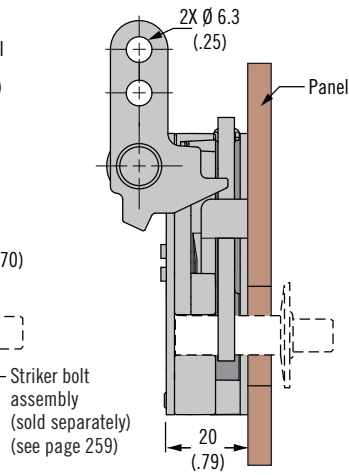

Part Number Selection

S Stage & Actuation
 1 Single stage, right hand
 2 Single stage, left hand
 3 Two stage, right hand
 4 Two stage, left hand

L Lever Type
 1 Perpendicular
 2 In-Line

I Mounting Style
 0 Ø7.2 (.283) thru
 1 1/4-20 thread
 2 M6 x 1 thread

B Base Style
 1 Standard
 5 Integrated bumper version

M Material
 10 Steel
 20 Stainless steel

R4 - 10 - S I - L O B - M

R4 Rotary Latch

Light-Duty · Concealed · Single and two stage



Single Stage - Two Point (left hand actuation shown)

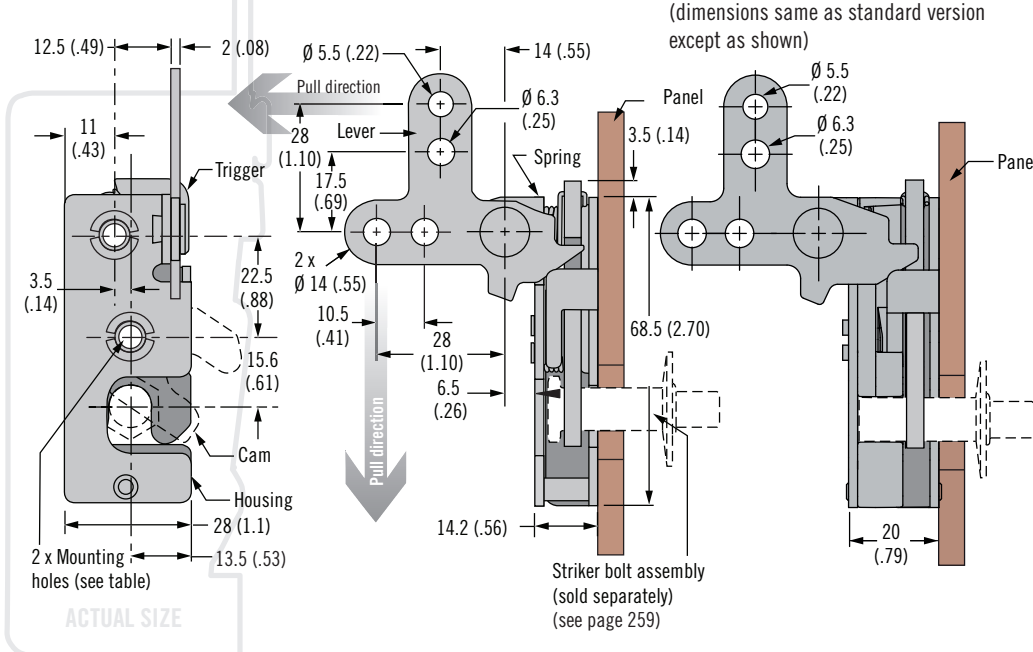

Integrated Bumper Version (dimensions same as standard version except as shown)

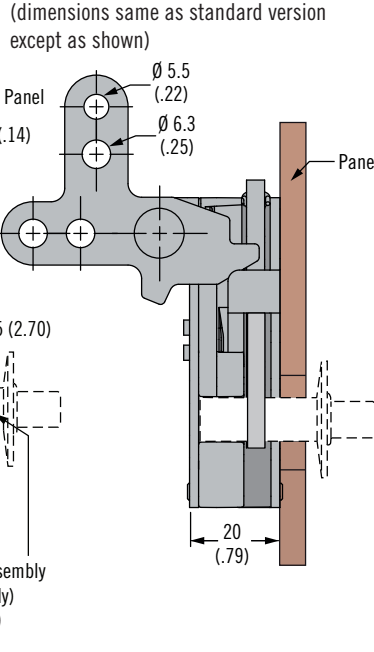

Single Stage - Hand Actuation

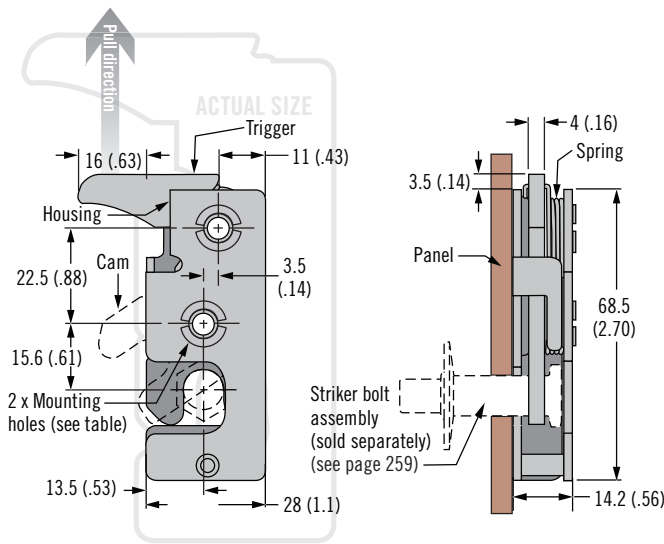

Integrated Bumper Version (dimensions same as standard version except as shown)

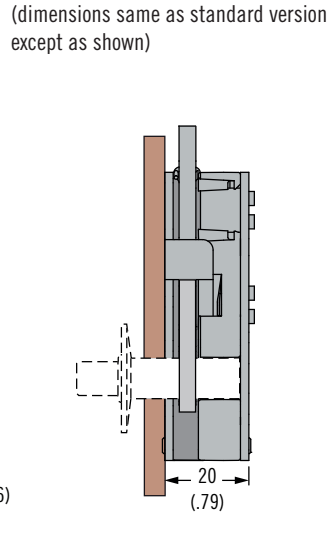

- Compatible with wide array of actuators
- EN 45545-3 E60 Compliant (Standard version only)
- Integrated bumper version for anti-vibration feature

Material and Finish

Steel, zinc plated or 304 stainless steel, passivated

Accessories

Striker bolts for standard version and integrated bumper version are different. See page 297 for both versions.

Cables and retainer clips see page 322-323

Notes

Electromechanical rotary latch available see page 20

Part Number Selection

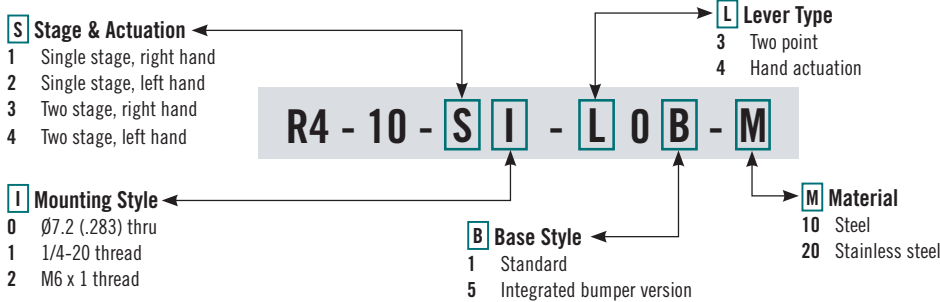

Dimensions in millimeters (inch) unless otherwise stated

www.southco.com/R4

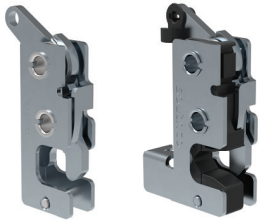

R4 Rotary Latch

Light-Duty · Concealed · Single and two stage

- Compatible with wide array of actuators
- EN 45545-3 E60 Compliant (Standard version only)
- Integrated bumper version for anti-vibration feature

Material and Finish

Steel, zinc plated or 304 stainless steel, passivated

Accessories

Striker bolts for standard version and integrated bumper version are different. See page 297 for both versions.

Cables and retainer clips see pages 322-323

Notes

Electromechanical rotary latch available see page 20

For electrical actuation option see page 43

Single Stage - Bottom

(left hand actuation shown)

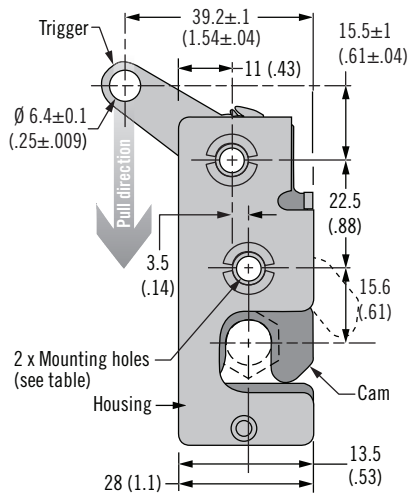

Integrated Bumper Version

(dimensions same as standard version except as shown)

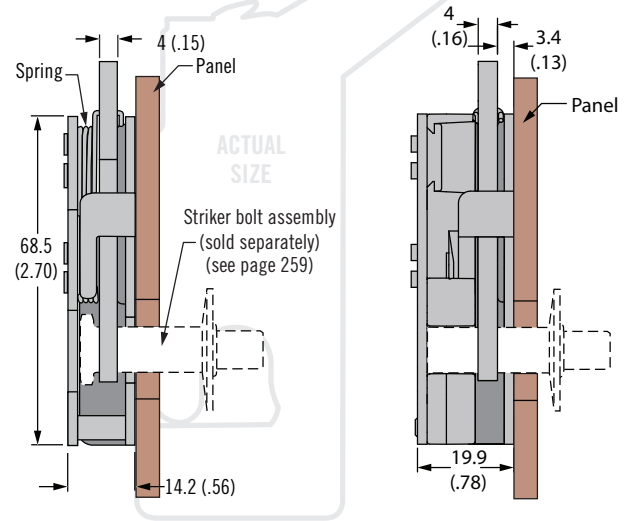

Single Stage - Bottom with Cable Bracket

(Right hand actuation shown)

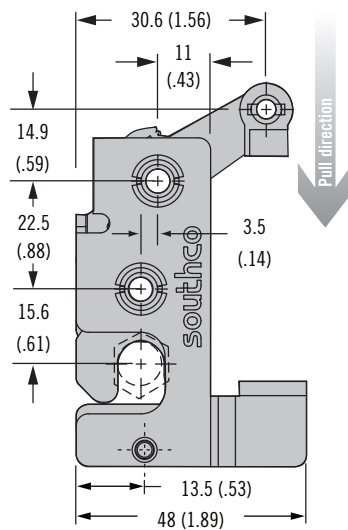

Integrated Bumper Version

(dimensions same as standard version except as shown)

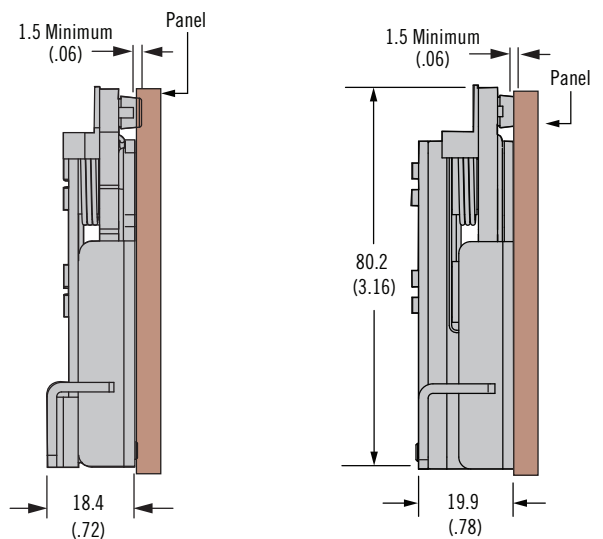

Part Number Selection

R4 - 10 - S I - 50 B - M

S Stage & Actuation

- 1 Single stage, right hand
- 2 Single stage, left hand
- 3 Two stage, right hand
- 4 Two stage, left hand

I Mounting Style

- 0 Ø7.2 (.283) thru
- 1 1/4-20 thread
- 2 M6 x 1 thread

B Base Style

- 1 Standard
- 2 Standard with cable bracket
- 5 Integrated bumper
- 6 Integrated bumper with cable bracket

M Material

- 10 Steel
- 20 Stainless steel

R4 Rotary Latch

Light-Duty · Concealed · Single and two stage



Single Stage - Top

(left hand actuation shown)

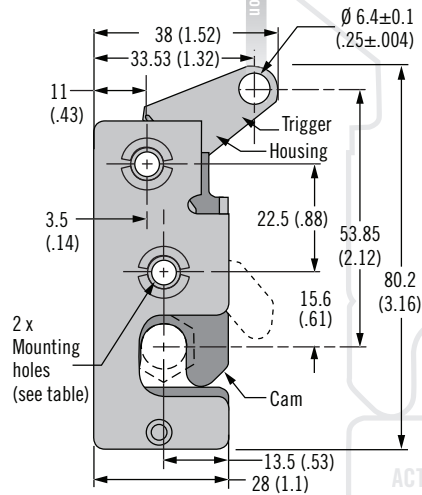

Single Stage - Direct Actuation

(left hand actuation shown)

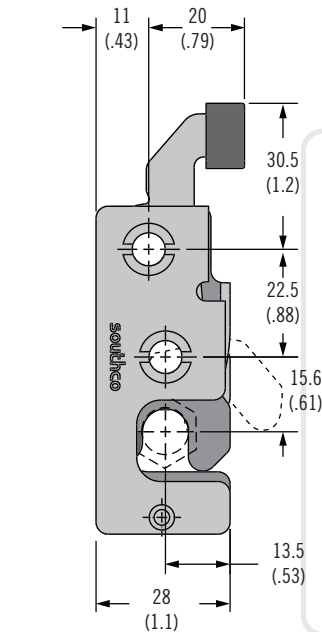

Integrated Bumper Version

(dimensions same as standard version except as shown)

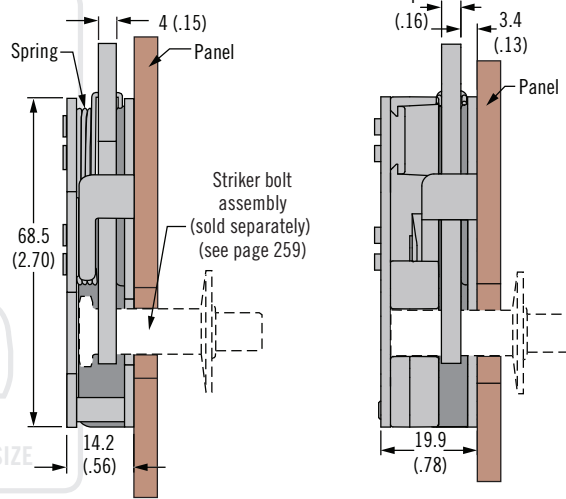

Integrated Bumper Version

(dimensions same as standard version except as shown)

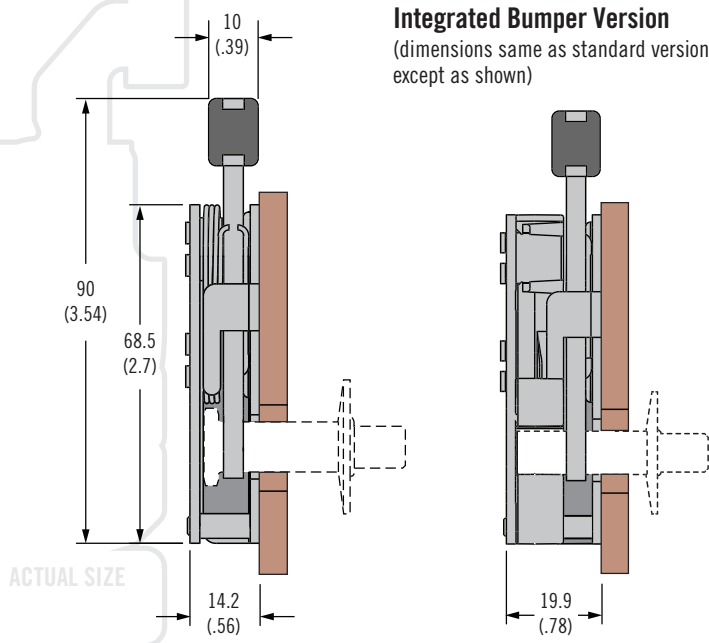

- Compatible with wide array of actuators
- EN 45545-3 E60 Compliant (Standard version only)
- Integrated bumper version for anti-vibration feature

Material and Finish

Steel, zinc plated

Accessories

Striker bolts for standard version and integrated bumper version are different. See page 297 for both versions.

Cables and retainer clips

see page 322-323

Trigger - use retaining clip

R4-0-43922-2

Lever - use retaining clip

R4-0-43922

Notes

Electromechanical rotary latch available see page 20

Part Number Selection

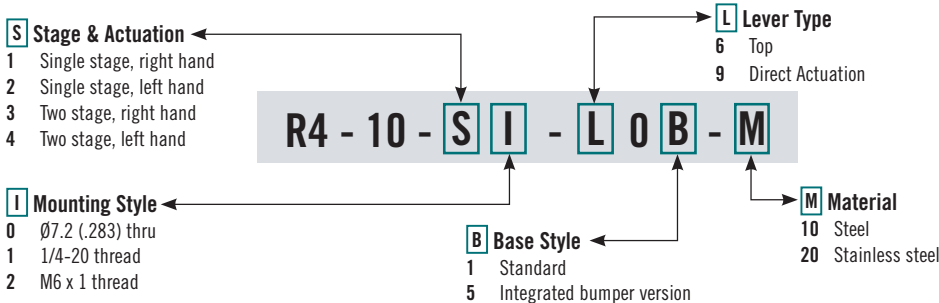

Dimensions in millimeters (inch) unless otherwise stated

www.southco.com/R4



R4 Rotary Latch

Light-duty · Concealed · Dual Trigger · Single and two stage

- Direct actuation, no cable or rod required
- Integrated bumper version for anti-vibration feature
- EN 45545-3 E60 Compliant (Standard version only)

Material and Finish

Steel, zinc plated or 304 stainless steel, passivated

Accessories

Striker bolts for standard version and integrated bumper version are different. See page 297 for both versions.

Notes

Electromechanical rotary latch available see page 20

For electrical actuation option for bottom lever designs, see page 43

Single Stage - Dual Trigger - Bottom
(left hand actuation shown)

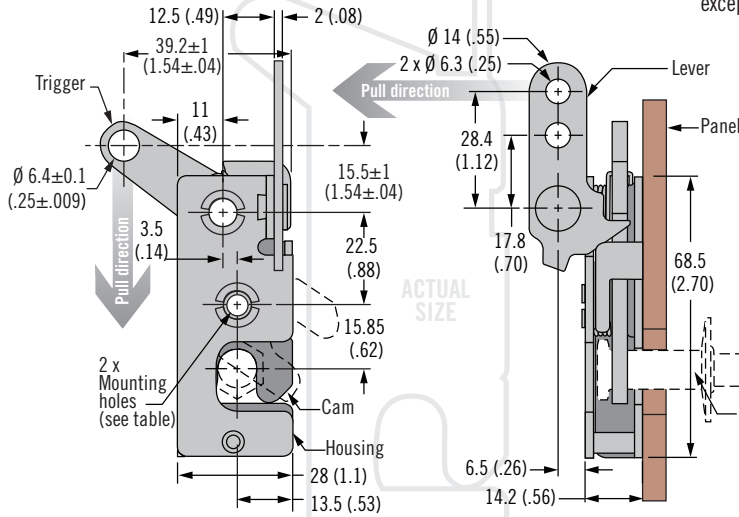

Integrated Bumper Version
(dimensions same as standard version except as shown)

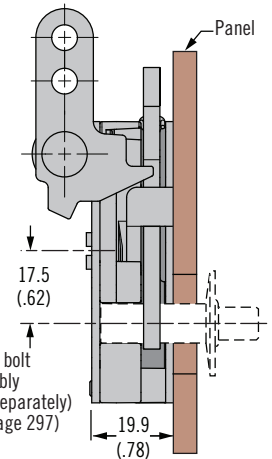

Single Stage - Dual Trigger - Top
(left hand actuation shown)

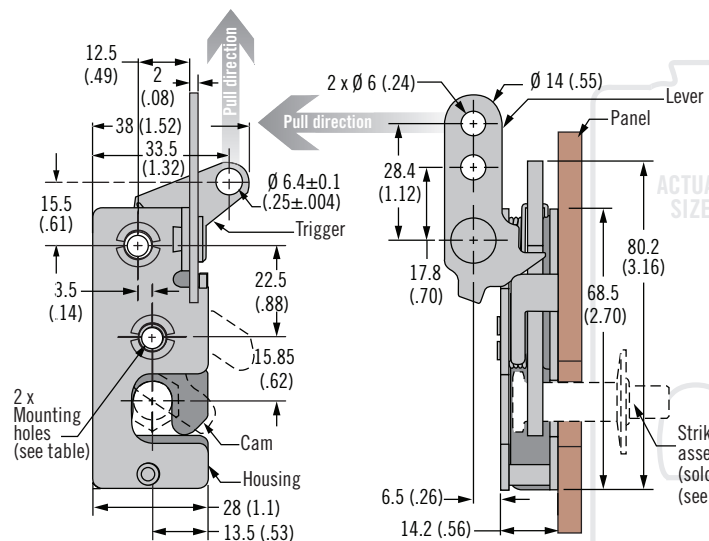

Integrated Bumper Version
(dimensions same as standard version except as shown)

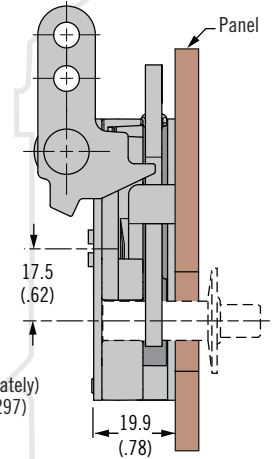

Part Number Selection

S Stage & Actuation

- 1 Single stage, right hand
- 2 Single stage, left hand
- 3 Two stage, right hand
- 4 Two stage, left hand

L Lever Type

- 7 Dual trigger, bottom
- 8 Dual trigger, top

I Mounting Style

- 0 $\varnothing 7.2$ (.283) thru
- 1 1/4-20 thread
- 2 M6 x 1 thread

B Base Style

- 1 Standard
- 5 Integrated bumper version

M Material

- 10 Steel

R4 - 10 - S I - L 0 B - M

R4 Rotary Latch

Striker bolt · Light-duty · Installation



Striker Bolt Assembly - Standard (sold separately)

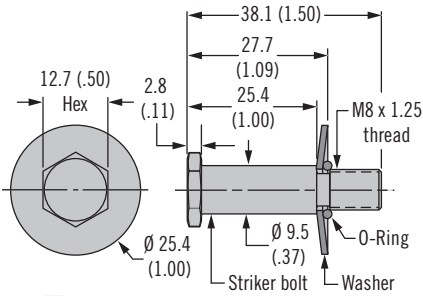

Striker Bolt Standard	
Part Number	Material
R4-90-121-10	Steel, Zinc Plated
R4-90-121-20	Stainless Steel

Striker Bolt Assembly - Integrated Bumper (sold separately)

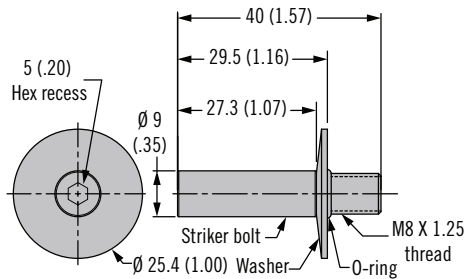

Striker Bolt Integrated Bumper	
Part Number	Material
R4-90-124-10	Steel, Zinc Plated
R4-90-124-20	Stainless Steel

Striker 90° Mounting Bracket

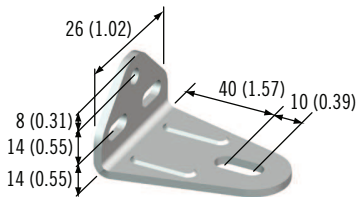

Striker Mounting Bracket	
Part Number	Material
R4-0-50114	Stainless Steel

Wire Form Strikers (sold separately)

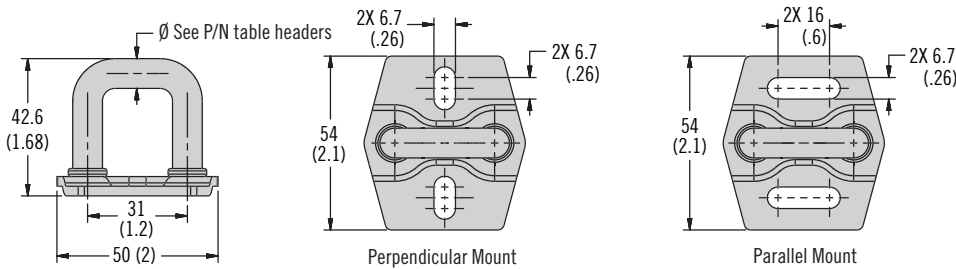

Wire Form Strikers - Standard Ø9.2 (.36)		
Part Number	Mount	Material
R4-90-101-10	Perpendicular	Steel, Zinc Plated
R4-90-101-15	Perpendicular	Steel, Black Zinc Nickel Plated
R4-90-101-77	Perpendicular	Steel, Zinc Nickel Plated
R4-90-102-10	Parallel	Steel, Zinc Plated
R4-90-102-15	Parallel	Steel, Black Zinc Nickel Plated
R4-90-102-77	Parallel	Steel, Zinc Nickel Plated

Wire Form Strikers - Integrated Bumper Ø9 (.35)		
Part Number	Mount	Material
R4-90-104-10	Perpendicular	Steel, Zinc Plated
R4-90-104-15	Perpendicular	Steel, Black Zinc Nickel Plated
R4-90-104-77	Perpendicular	Steel, Zinc Nickel Plated
R4-90-106-10	Parallel	Steel, Zinc Plated
R4-90-106-15	Parallel	Steel, Black Zinc Nickel Plated
R4-90-106-77	Parallel	Steel, Zinc Nickel Plated

• Strikers for R4-10 series rotary latch

Material and Finish

Steel, zinc plated Steel, zinc nickel plated, Steel, black zinc nickel plated, Stainless Steel, passivated

Operation

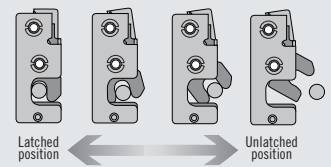

Part Number

See tables