

R2 Draw Latch

Concealed · Panel Fastening

- Provides a high strength concealed joint
- Operates quickly with a hex wrench
- Self adjusts to ensure a tight connection

Material and Finish

Steel, galvanized

Performance Details

Tab, Shallow, and Mortise Mount:

Average ultimate tensile load:
6200 N (1400 lbf)

Average ultimate shear load:
8900 N (2000 lbf)

Front Mount: Average ultimate
tensile load: 4000 N (900 lbf)

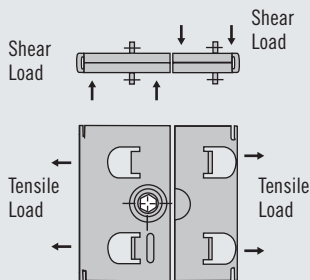

Latch

Tab Mount

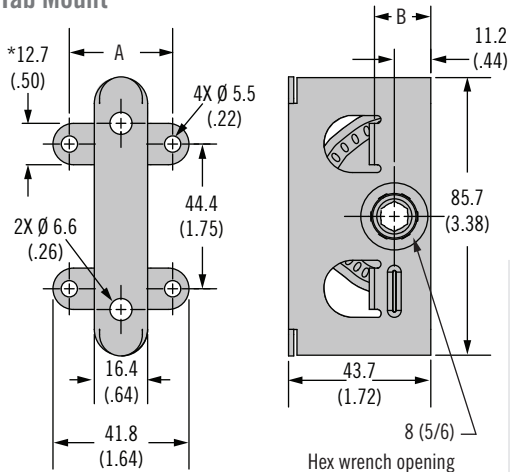

Receptacle

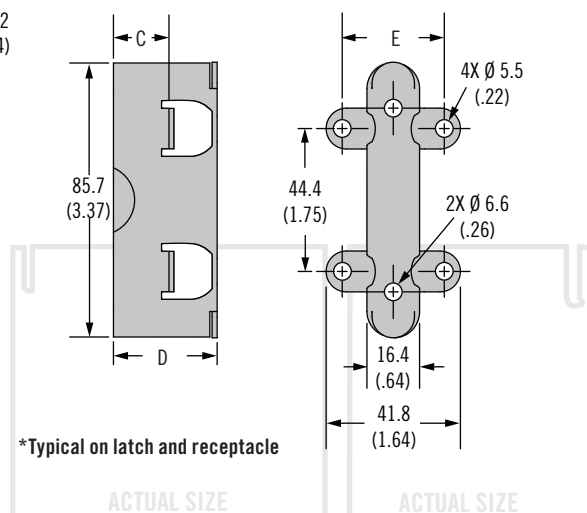

Mortise Mount

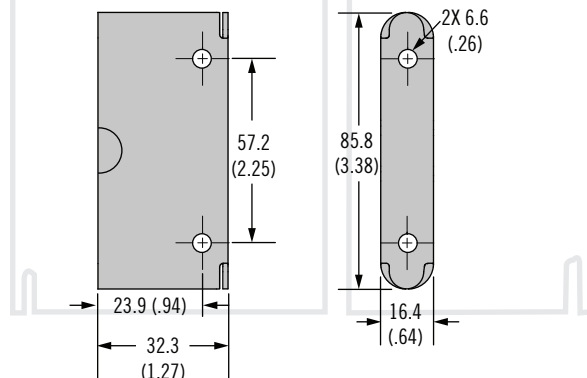
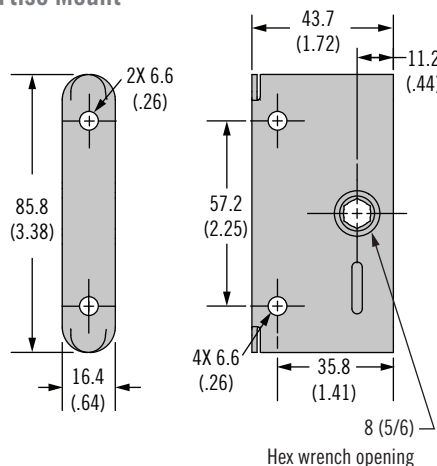

Front/Rear Mount

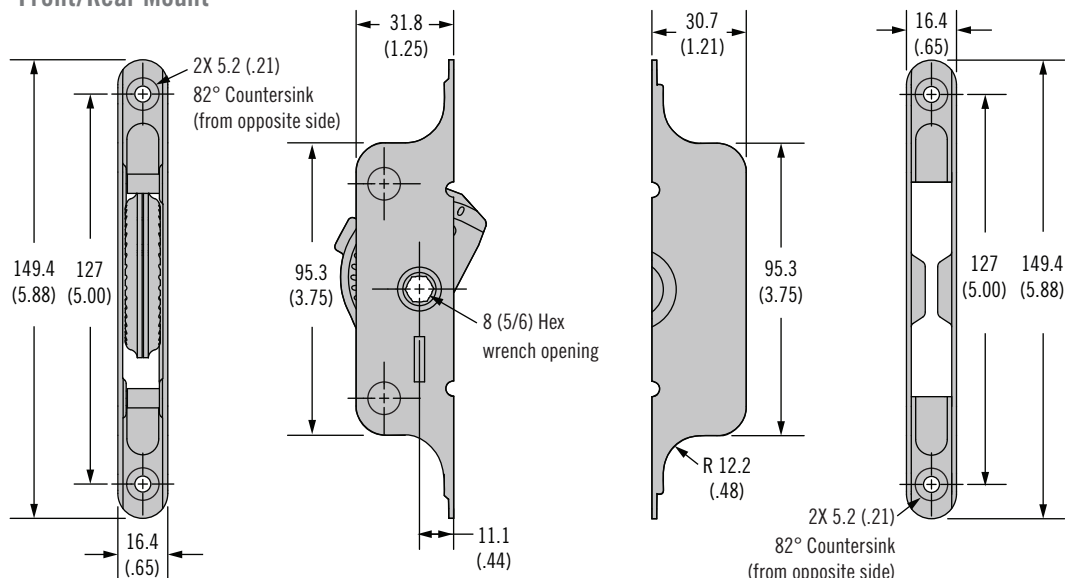

Other options available. For complete details on variety, part numbers, installation and specification, go to



Dimensions in millimeters (inch) unless otherwise stated

R2 Draw Latch

Concealed · Panel Fastening

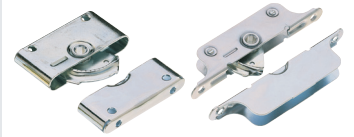

Tab Mount

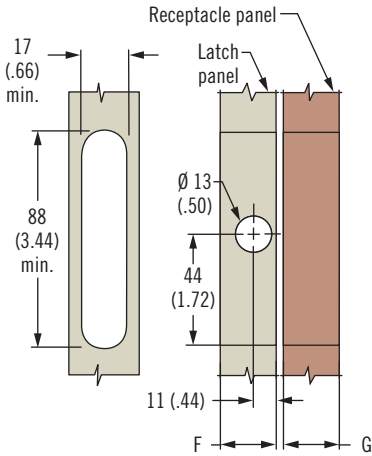

Mortise Mount

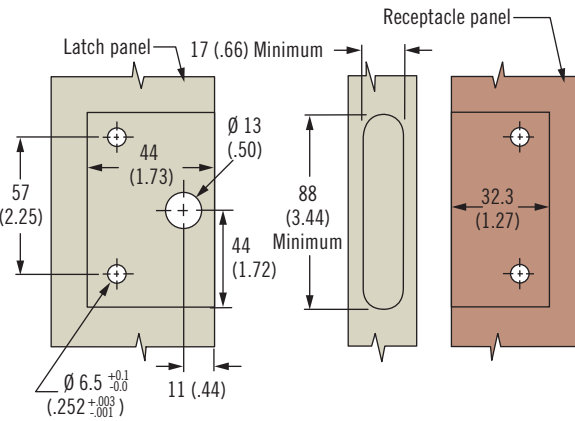

Front Mount

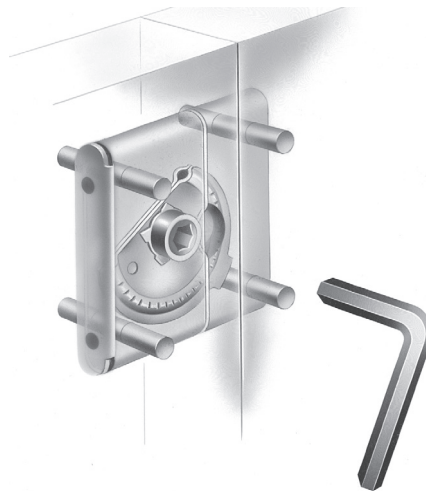
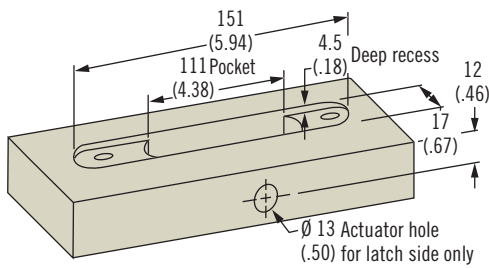

Rear Mount

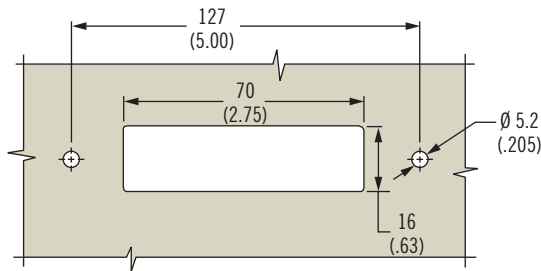

Installation Notes

Tab Mount: Install with Ø 5 (.205) rivets or M5 (No. 10) screws (not supplied)

Mortise Mount: Install with Ø 6 (1/4) rivets or M6 (1/4) screws (not supplied). A 1.6 (.06) gap should be maintained between latch and receptacle.

Front Mount - Wood application: Install with M5 (No. 10) flat head screws (not supplied). Note: Latch strength is dependant on mounting hardware and installation material

Rear Mount - Metal application: Install with 5 (.196) flathead rivets or M5 (No. 10) screws. Note: Maximum metal panel thickness should be 2.5 (.10)

Accessories

Actuation tool
Part number: 29-0059-02

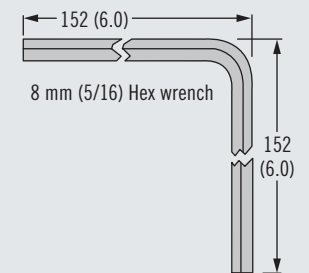

Mounting Style	Part Number	A	B	C	D	E	F	G
Shallow Tab Mount	Latch	R2-0259-17	31.8 (1.25)	17.3 (.68)	17.3 (.68)	32.3 (1.27)	31.8 (1.25)	19 (.75)
	Receptacle	R2-0257-17						
Deep Tab Mount	Latch	R2-0169-17	28.7 (1.13)	30.2 (1.19)	38.1 (1.50)	52.1 (2.05)	28.7 (1.13)	32 (1.25)
	Receptacle	R2-0160-17						
Mortise Mount	Latch	R2-0055-17	28.7 (1.13)	30.2 (1.19)	38.1 (1.50)	52.1 (2.05)	28.7 (1.13)	32 (1.25)
	Receptacle	R2-0002-17						
Front/Rear Mount	Latch	R2-0267-17	28.7 (1.13)	30.2 (1.19)	38.1 (1.50)	52.1 (2.05)	28.7 (1.13)	32 (1.25)
	Receptacle	R2-0268-17						

Part Number

See table
Order latch and receptacle separately

