



P2 Flush Pull - Lockable

Low profile · Lift or pull · Single hole mount

- Snap-in installation
- Lockable
- Lock core included or sold separately
- Cam sold separately

Material and Finish

Pull: ABS plastic, black

Lock parts:

Zinc alloy powder coated,
Brass, Steel zinc plated, Buna-N

Flammability Rating

UL94-HB or UL94-V0

Notes

"For pulls without lock core, lock core sold separately, see page 183.

"Cam sold separately. See our handbook page 191 or www.southco.com."

Type B (Counter-Clockwise) Version Shown

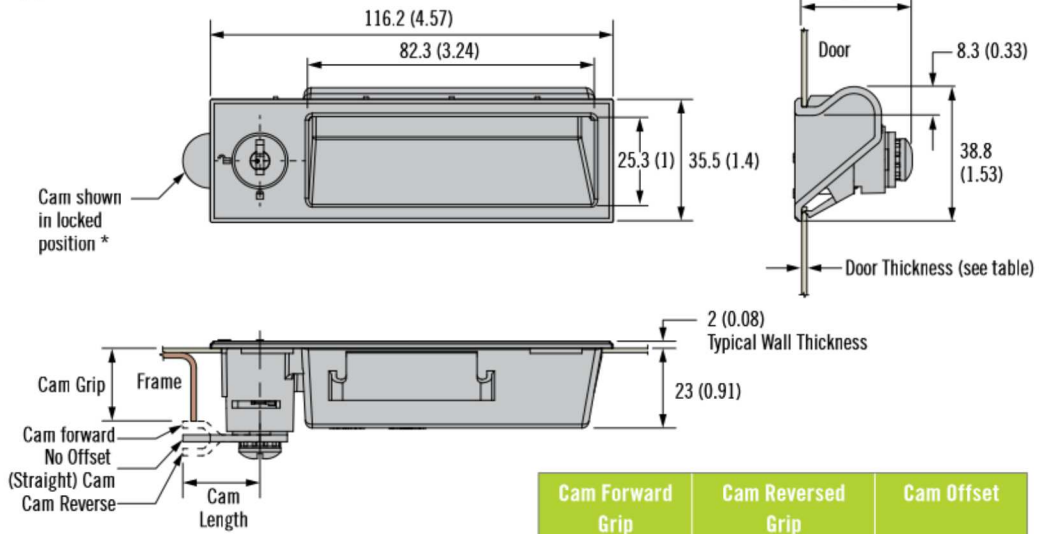

Cam Forward Grip	Cam Reversed Grip	Cam Offset
25 (0.98)	25 (0.98)	No Offset
21.8 (0.86)	28.2 (1.11)	3.2 (1.25)
18.6 (0.73)	31.4 (1.24)	6.4 (.250)
15.5 (0.61)	34.5 (1.36)	9.5 (.375)

* Cam Ordered Separately
For Cam Part Numbers and options see our handbook page 191 or www.southco.com

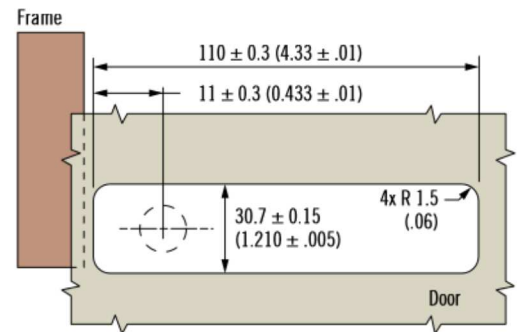
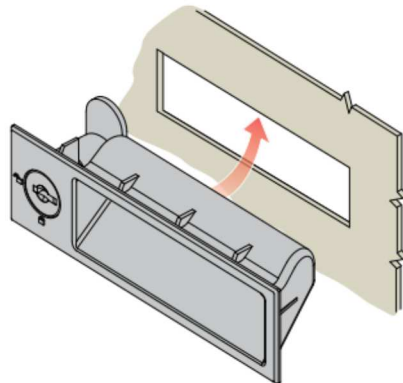

Part Number Selection

(*Cam Ordered Separately)

D Door Thickness Range

- 1.0 (.040) - 1.4 (.055)
- 1.4 (.055) - 1.8 (.070)
- 1.8 (.070) - 2.1 (.085)
- 2.1 (.085) - 2.5 (.100)

M Material

- 1 UL94-V0 PC/ABS
- 2 UL94-HB ABS

P2 - 4 D M - R L

R Rotation

- 1 Type A (Clockwise)
- 2 Type B (Counter-Clockwise)

L Lock Style

- 2 With lock core, keyed alike CH751 (with two flat keys supplied)
- 9 Without lock core (See our handbook page 183 or visit www.southco.com)

Dimensions in millimeters (inch) unless otherwise stated

Global Corporate Headquarters and Americas Customer Service & Technical Support Center
Concordville, PA – USA · Tel: (1) 610-459-4000 · Fax: (1) 610-459-4012

southco
CONNECT · CREATE · INNOVATE

Other options available. For complete details on variety, part numbers, installation and specification, go to



www.southco.com/P2

© Southco P2 875NA 04-13



Lock Cores - Disc Tumbler

Lock Core Part Number						
Keying	Key code	Bag qty	Shuttered stainless steel scalp	Non shuttered stainless steel scalp	Non shuttered black powder coated	Non shuttered chrome plated
KA	CH751	1	PK-39-72-13-KCH751	PK-132-13	PK-115-13	PK-116-13
KA	RS001	1	PK-39-72-13-RS001	PK-132-13-RS001	PK-29-15-13-RS001	PK-29-16-13-RS001
KD	10 CODES	10	PK-39-72-13-KD1010	PK-132-13-KD1010	PK-29-15-13-KD1010	PK-29-16-13-KD1010
KD	50 CODES	50	PK-39-72-13-KD1050	PK-132-13-KD1050	PK-29-15-13-KD1050	PK-29-16-13-KD1050
KD	125 CODES	125	PK-39-72-13-KD1125	PK-132-13-KD1125	PK-29-15-13-KD1125	PK-29-16-13-KD1125
MKKD	10 CODES	10	PK-39-72-13-MK1010	PK-132-13-MK1010	PK-29-15-13-MK1010	PK-29-16-13-MK1010
MKKD	50 CODES	50	PK-39-72-13-MK1050	PK-132-13-MK1050	PK-29-15-13-MK1050	PK-29-16-13-MK1050
MKKD	125 CODES	125	PK-39-72-13-MK1125	PK-132-13-MK1125	PK-29-15-13-MK1125	PK-29-16-13-MK1125

Keys	Part Number
Master Key (1)	PK-24-01
Control (Removal) Key (1)	PK-11-03

Lock Cores - Tool Operable

Head Style	Lock Core Part Number			
	Phillips recess	Slotted	4 mm Hex recess	8 mm Hex recess
Chrome plated	PK-0-34027-01	PK-0-43489-01	PK-0-34323-01	PK-0-40374-01
Black powder coated	PK-0-34027-50	PK-0-43489-50	PK-0-34323-50	PK-0-40374-50

Key code selection

- KA - Keyed Alike:**
All lock cores are the same key code
- KD - Keyed Differently:**
Multiple key codes provided in a non-master key system
- MKKD - Master Keyed, Keyed Differently:**
Multiple key codes provided in a master key system

Notes

Part Number includes 1 lock core and 2 keys

Lock Core Installation for CM-3 and CM-6 only (see page 188)

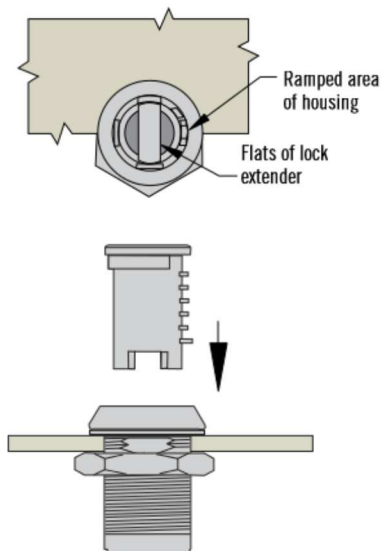

01 (Clockwise)

Lock Core Installed (01 Rotation)

Unlocked Position Locked Position

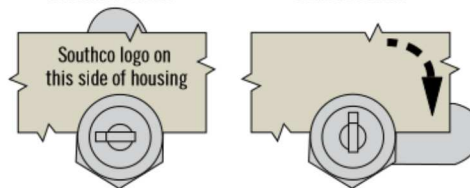

09 (Counter-Clockwise)

Lock Core Installed (09 Rotation)

Unlocked Position Locked Position

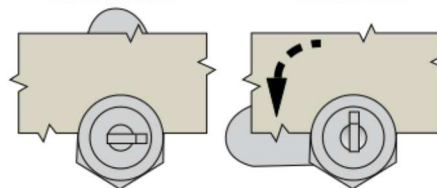

Southco logo on this side of housing

Dimensions in millimeters (inch) unless otherwise stated

Installation Notes

1. Prepare panel and install latches shown on page 188.
2. Latch should be in unlatched position. The flats of the lock extender should be aligned with the flats on the housing.
3. Take a lock core and orient the brass wafers to the internal ramped area of the housing. Push lock core into housing until it stops.
4. Insert key into lock core and turn to verify lock core is fully seated and operating properly.
5. Install cam.

CM Cam Locks

Cams & installation

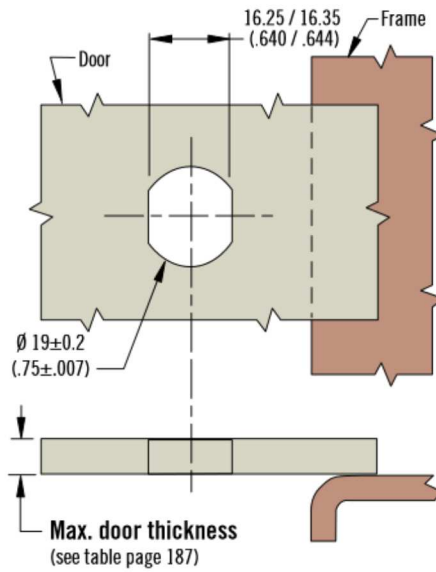
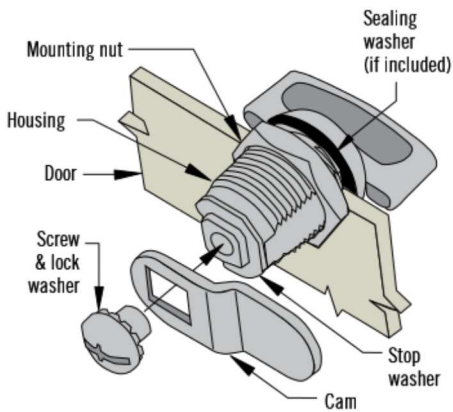

Installation Notes

1. Place sealing washer onto housing (if included) and put through the mounting hole (see panel preparation).
2. Install mounting nut and tighten to 5 N·m (44 in·lbf).
3. Install cam to assembly. Properly orientate for rotation and grip.
4. Install screw. Tighten to 4 N·m (35 in·lbf).

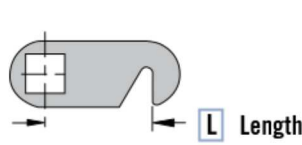
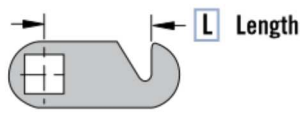
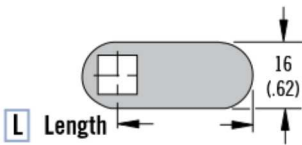
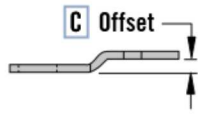
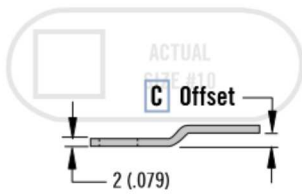

S C - No hook

S H - Hook type 1

S L - Hook type 2

Material and Finish

Cam: Steel plated

Part Number Selection

Order lock and cam separately

Cam part number (no lock)

For Lock selection see pages 188 - 190

