

ACCESS HARDWARE

MP Novibra Push-to-Close Latch · Medium · Plastic · Turn to Open

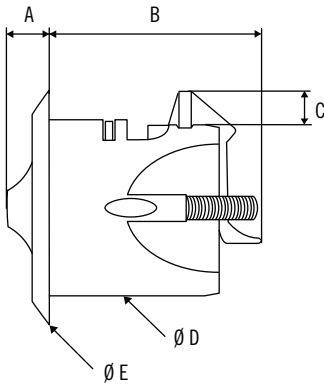

	Imperial		Metric
	Nominal	Decimal	
A	15/32	.472	12
B	1 3/4	1.752	44.5
C	13/32	.406	10
D	1 1/2	1.5	38
E	1 3/4	1.76	44.7



- Fast, easy installation
- Weatherproof face
- Long bolt travel with an adjustable striker plate

Panel Thickness Range:

3 - 22mm (1/8" - 7/8")

The Novibra is designed for hatches, doors, drawers, cockpit lockers, and similar type applications. The Novibra helps eliminate noise in the hatch, doors or drawers caused by engine vibration.

Available Options:

Colors: Choose from black, white, chrome, diamond brass, and satin, in any combination of Cup and Handle. Additional colors and custom color-matching available on request. Contact Southco for details.

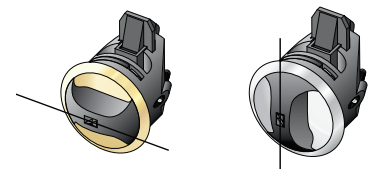

Type 1
(For drawers)

Type 2
(For doors)

Non vibration feature

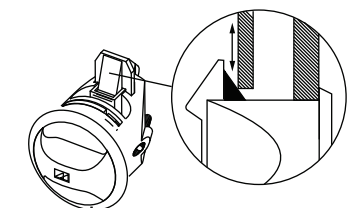

Panel Preparation

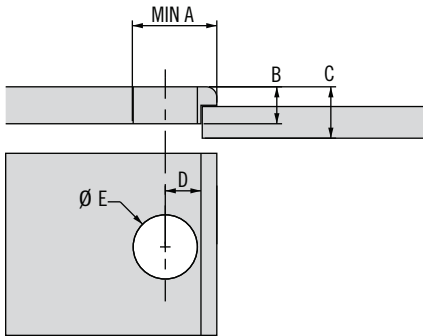

	Imperial		Metric
	Nominal	Decimal	
A	2	2	50
B	min. 1/8 max. 7/8	.118 .875	3 22.5
C	min. 7/8 max. 1 5/16	.875 1.313	23 33
D	1 7/32	1.219	31
E	1 33/64	1.516	38.5

Installation

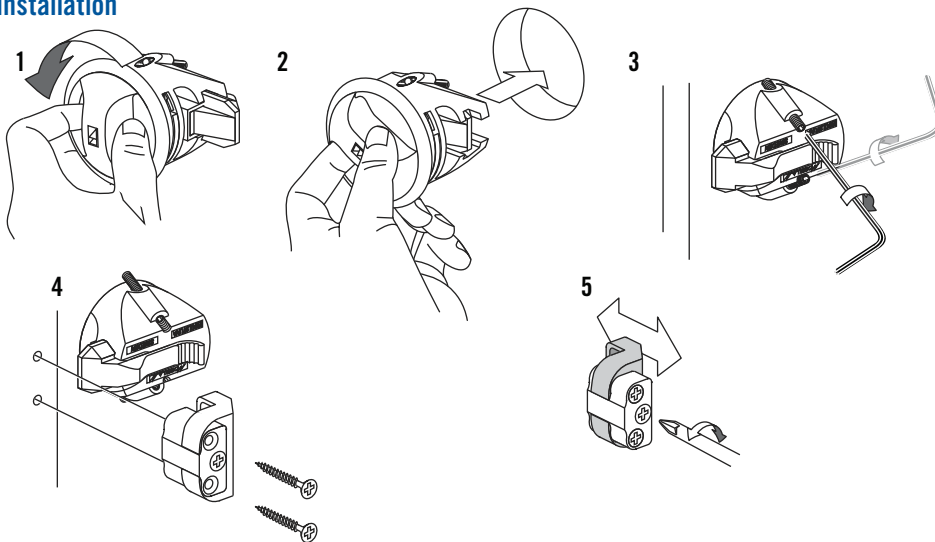

Part Number Selection

T Type
 1 For Drawers
 2 For Doors

C Cup
 1 Chrome
 2 Satin
 3 Brown
 4 Diamond Brass
 5 Black
 7 White

B Body
 5 Black
 7 White

H Handle
 1 Chrome
 2 Satin
 3 Brown
 4 Diamond Brass
 5 Black
 7 White

MP - 0 T - 103 - B C H

