



# M1 Push-to-Close Latch

Large · Stainless steel

- Single, round-hole installation
- Corrosion-resistant materials
- Inside actuation when locked or unlocked

### Material and Finish

Stainless steel 316 grade electro polished

### Performance Details

Max. working load: 835 N (187 lbf)

Operating temperature range: -18°C (0°F) to 60°C (140°F)

### Installation Notes

Max. tightening torque on mounting screws: 1.7 N·m (15 in·lbf)

### Accessories

Keeper

Part number: M1-525-19-4

For lock style 4

Key (pair)

Part number: M1-546



For lock style 7

Overmolded key S008 (pair)

Part number: M1-525-39-S008



Replacement mounting screw

Part number: M1-0-27358-02

### Part Number Selection

See page 71 for complimentary styled compression version

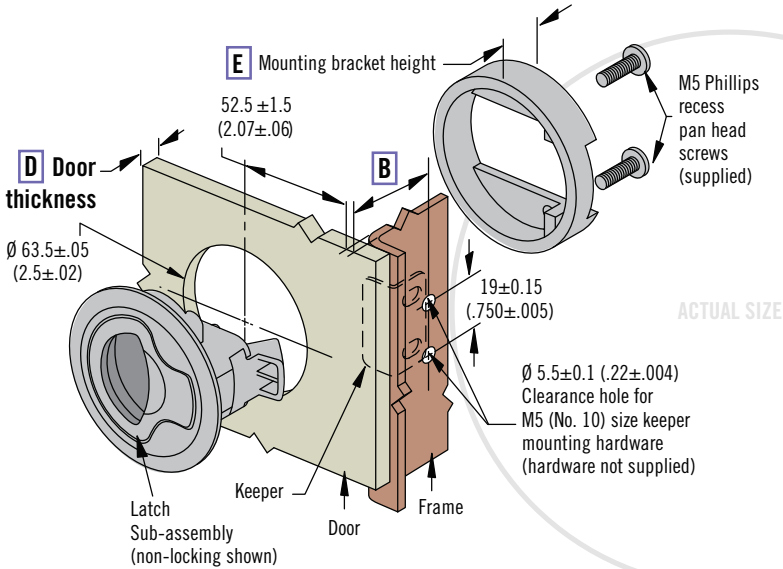
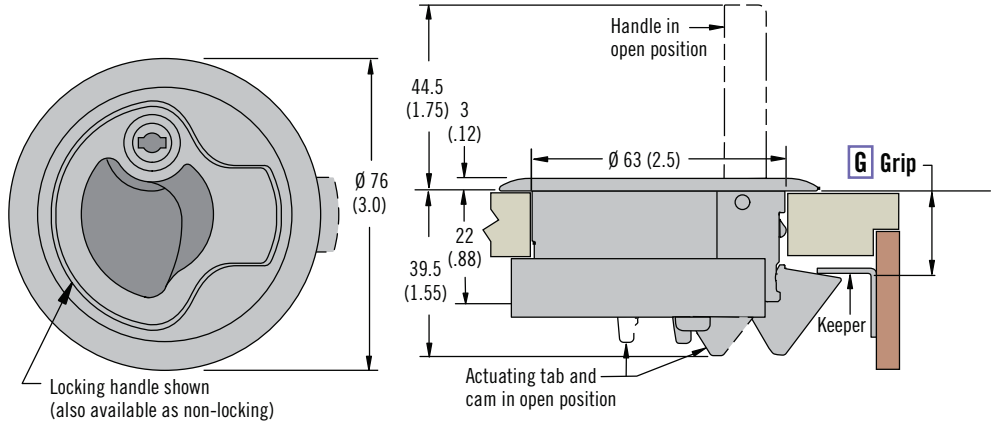

G Grip	E Mounting Bracket Height	D Door Thickness		B
		Min.	Max.	
20±0.5 (.75±.02)	22 (.875)	2 (.075)	12 (.475)	27 (1.10)
32±0.5 (1.25±.02)	22 (.875)	2 (.075)	12 (.475)	39 (1.54)
20±0.5 (.75±.02)	12 (.475)	12 (.475)	22 (.875)	27 (1.10)
32±0.5 (1.25±.02)	12 (.475)	12 (.475)	22 (.875)	39 (1.54)

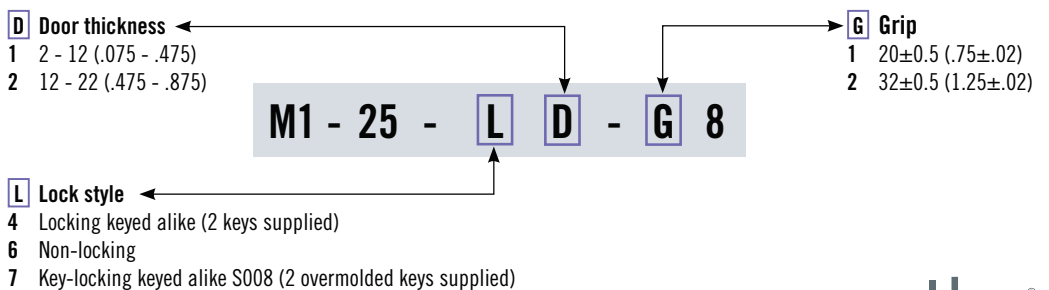

Dimensions in millimeters (inch) unless otherwise stated