



LG Quick-Release Pins

Single acting pins

- Positive locking
- Push button to release
- Hardened and ground for strength and precision

Material and Finish

Body: Hardened stainless steel
Handle: Aluminum, black anodized or stainless steel passivated

Notes

Southco is a QSLM certified manufacturer of quick-release pins. The *LOCKWELL*® Quick-Release Pins on this page can be manufactured to the specification of NAS 1333 thru NAS 1346 and MS 17984 thru MS 17987. Parts ordered to MS and NAS specification are certified to NAS 1332 and NASM 23460.

Additional pin configurations and sizes, including metric pins are available on request.

Handles - Aluminum

Style BA

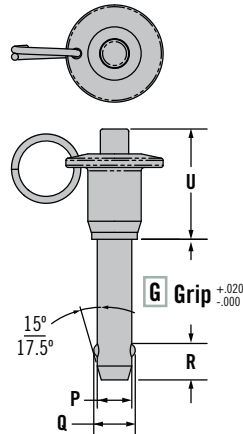

Style T

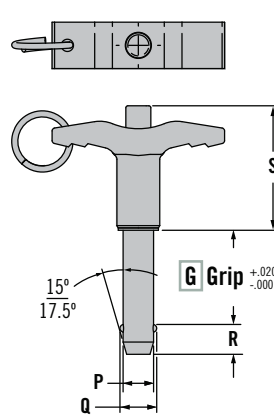

Style L

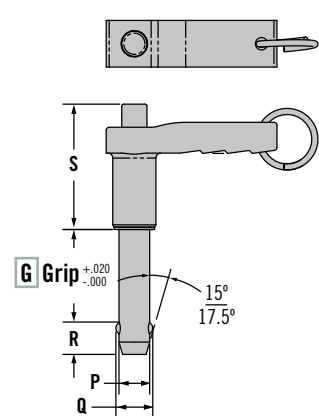

Handles - Stainless steel

Style B

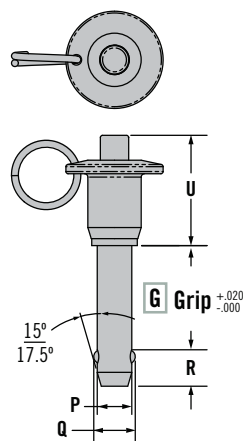

Style R

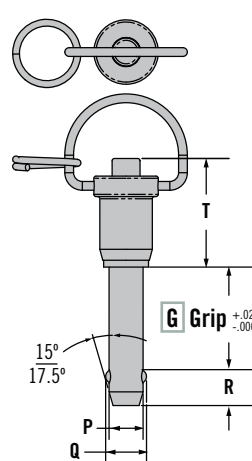

Style Y

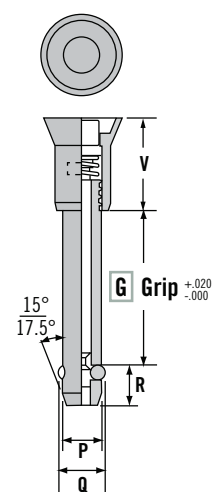

Nominal Pin Diameter	D Pin Size	Min. Tension Load Capabilities		Calculated Double Shear Strength	Ø Install Hole	
		2-Ball Construction	4-Ball Construction		Min.	Max.
3/16	3	200 lbf	260 lbf	5150 lbf	.190	.194
1/4	4	230 lbf	290 lbf	9200 lbf	.250	.254
5/16	5	510 lbf	630 lbf	14400 lbf	.3125	.3165
3/8	6	575 lbf	740 lbf	20600 lbf	.375	.379
7/16	7	710 lbf	920 lbf	28000 lbf	.4375	.4425
1/2	8	1160 lbf	1500 lbf	36800 lbf	.500	.505
9/16	9	1420 lbf	1840 lbf	46000 lbf	.5625	.5675
5/8	10	2070 lbf	2690 lbf	57500 lbf	.625	.630
3/4	12	2950 lbf	3835 lbf	82500 lbf	.750	.757
7/8	14	3900 lbf	5070 lbf	112500 lbf	.875	.882
1	16	5480 lbf	7120 lbf	147000 lbf	1.000	1.010

Nominal Pin Diameter	D Pin Size	Dimensions						
		P +0 -.0015	Q ±.005	R	S Max.	T Max.	U Max.	V Max.
3/16	3	.1885	.220	.260	1.270	.730	.830	.890
1/4	4	.2485	.289	.290	1.270	.780	.890	.950
5/16	5	.3110	.375	.330	1.270	.830	.930	.990
3/8	6	.3735	.440	.365	1.450	.940	1.040	1.090
7/16	7	.4360	.509	.380	1.470	.980	1.160	1.220
1/2	8	.4985	.594	.460	1.600	1.140	1.190	1.250
9/16	9	.5610	.666	.510	1.600	1.140	1.410	1.470
5/8	10	.6235	.750	.580	1.700	1.400	1.500	1.560
3/4	12	.7485	.887	.670	1.720	1.625	1.680	1.740
7/8	14	.8735	1.046	.760	2.170	1.875	1.985	2.045
1	16	.9985	1.219	.890	2.170	2.000	2.140	2.200

Part Number Selection

Example: LG-4CBA1000F
 1/4 inch diameter, aluminum button handle, 1 inch grip length, 4-ball construction

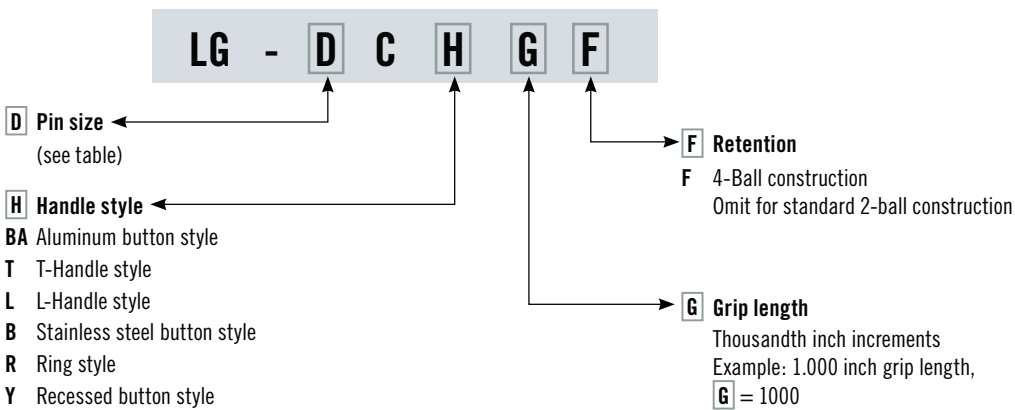

Dimensions in inches unless otherwise stated



www.southco.com/LG