

REVISION HISTORY			
REV	DATE	BY	DESCRIPTION
F	19OCT2018	RCS/EMI	PRN: P2018-2423

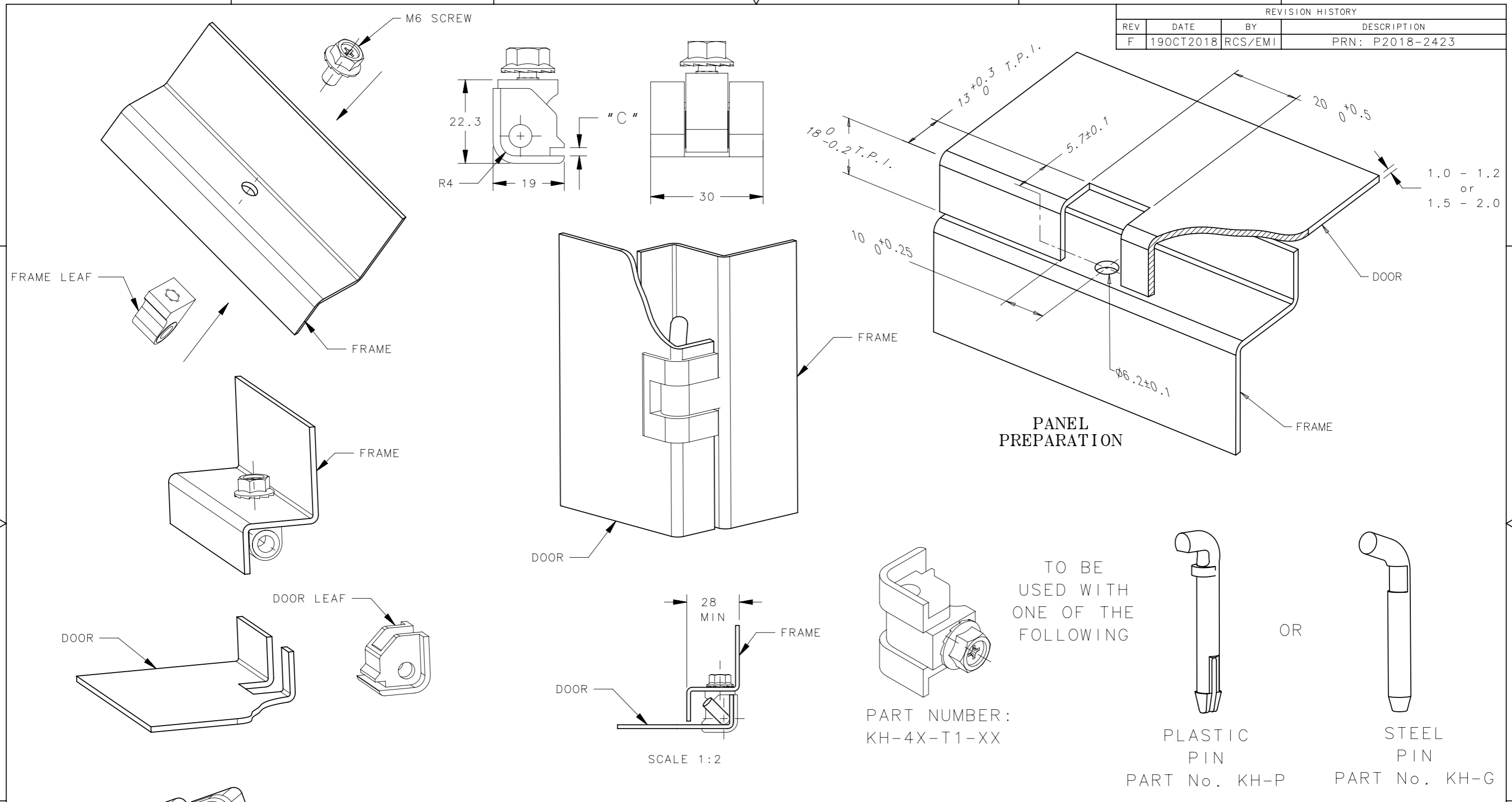

NOTES:
 A. COSMETIC SPECIFICATION:
 ALL SURFACES ARE TO CONFORM TO A CLASS "B" DESIGNATION AS DESCRIBED IN SOUTHCO COSMETIC SPECIFICATIONS:
 S-121-01 FOR CHROME PLATING
 S-121-03 FOR POWDER COATING
 B. PACKAGING: TRAY PACKAGED SHIPPED (50) PER BOX.
 C. INSTALLATION:
 1. LOOSELY ATTACH FRAME LEAF TO FRAME WITH M6 SCREW.
 2. SLIDE DOOR LEAF INTO CUTOUT IN DOOR.
 3. ALIGN HOLES IN FRAME LEAF AND DOOR LEAF AND INSERT PIN (PIN ORDERED SEPARATELY).
 4. TIGHTEN M6 SCREW TO FRAME.
 MAX TIGHTENING TORQUE: 5 N·m / 45 lbf·in.

KH-42-T1-50	CORNER HINGE	DIE CAST ZINC	BLACK POWDER COAT	1.5mm - 2.0mm	2.2mm
KH-42-T1-38	CORNER HINGE	DIE CAST ZINC	CHROME PLATED	1.5mm - 2.0mm	2.2mm
KH-41-T1-50	CORNER HINGE	DIE CAST ZINC	BLACK POWDER COAT	1.0mm - 1.2mm	1.5mm
KH-41-T1-38	CORNER HINGE	DIE CAST ZINC	CHROME PLATED	1.0mm - 1.2mm	1.5mm
PART NUMBER	TYPE OF COMPONENT	MATERIAL	FINISH	PANEL THICKNESS	C

THIRD ANGLE PROJECTION					
MILLIMETERS [IN]					
TOLERANCES UNLESS OTHERWISE NOTED		DESCRIPTION			
SURFACE AREA		KH CORNER HINGE, SMALL			
VOLUME		VERSION A			
PROPRIETARY ITEM		SIZE	SYSTEM	DWG NO.	
EXCEPT FOR USES EXPRESSLY GRANTED IN WRITING, INFORMATION DISCLOSED HEREON IS CONFIDENTIAL AND ALL RIGHTS, PATENT AND OTHERWISE, ARE RESERVED BY SOUTHCO, INC.		A3	NX	J-KH-42-T1	
PER ASME Y14.5M-1994		DRAWN BY	DATE	SCALE	SHEET
		AJH/DLH	13APR2005	1:1	1 OF 1

southco[®]
 CONNECT · CREATE · INNOVATE