



E5 Cam Latch

Zinc · Wing style · Fixed grip

- Single hole install
- Multiple key codes
- Easy finger grip

Material and Finish

Wing: Zinc alloy, black powder coated and steel, zinc plated

Performance Details

Maximum static load: 330 N (74 lbf)

Sealing Notes

NEMA 4 / IP65 achieved using gasket supplied

Installation Notes

Mounting nut maximum tightening torque: 10 N·m (88 in·lbf)

Screw Maximum tightening torque: 5 N·m (45 in·lbf)

Keys

See page 130

Notes

Wing style suitable for push-to-close action see page 128

For lock core selection and a complete overview of the *SOUTHCO*® Key-Choice System see page 158

Part Number Selection

Order latch and cam separately

Wing

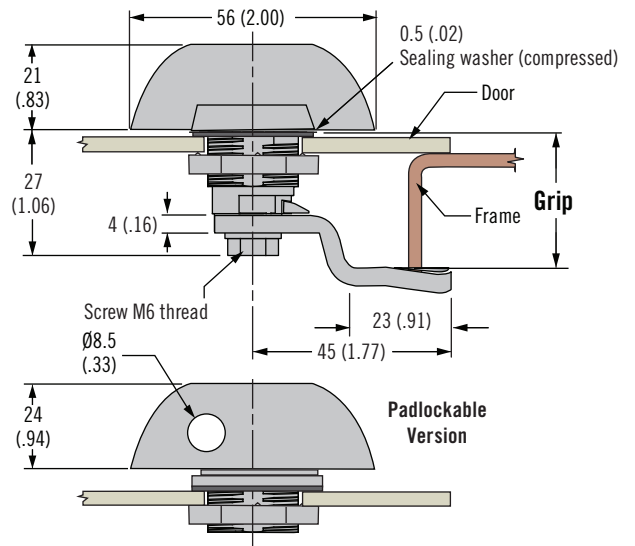
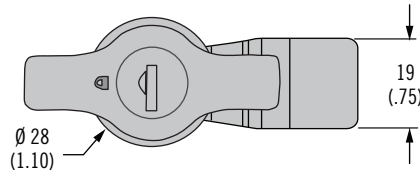

L Lock Styles

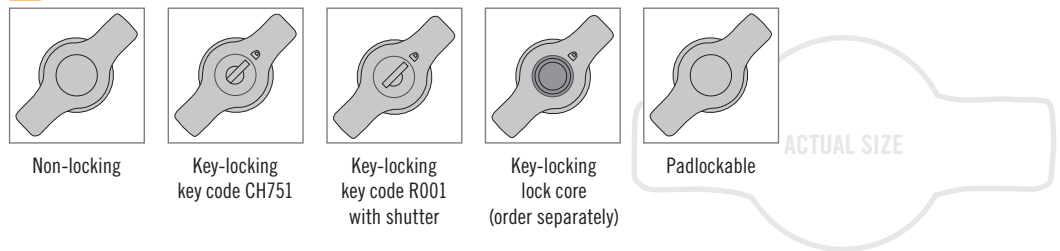

Latch Part Number
(no cam)

E5 - 9 - L 5 - UU1 - 1 K

K Key options

- 0 No keys supplied (order separately, see page 130)
- 3 1 Overmolded key supplied

L Lock style

- 30 Non-locking (omit last two digits of part number)
- 31 Key-locking black lock core keyed alike CH751
- 32 Key-locking stainless steel scalp and shuttered lock core keyed alike R001
- 33 Without lock core (omit last two digits of part number) Order lock core separately, see page 158
- 51 Padlockable, Type A clockwise to latch (omit last two digits in part number)
- 52 Padlockable, Type B counter-clockwise to latch (omit last two digits in part number)

Cam Part Number

E5 - 6 L G

L Lock style

- 0 Non-locking or Key-locking
- 1 Padlockable

G Grip

Grip	G	Grip	G	Grip	G	Grip	G
4 (.16)	03	14 (.55)	08	24 (.94)	13	34 (1.34)	18
6 (.24)	04	16 (.63)	09	26 (1.02)	14	36 (1.42)	19
8 (.31)	05	18 (.71)	10	28 (1.10)	15	38 (1.50)	20
10 (.39)	06	20 (.79)	11	30 (1.18)	16	40 (1.57)	21
12 (.47)	07	22 (.87)	12	32 (1.25)	17	42 (1.65)	22

