

E5 Cam Latch

Zinc · Wing style · Padlockable wing style · Fixed grip

- Single hole install
- Multiple key codes

Material and Finish

Wing: Zinc alloy, black powder coated and steel, zinc plated

Padlockable wing: Zinc alloy, chrome plated and steel, zinc plated

Performance Details

Max. static load: 330 N (74 lbf)

Sealing Notes

Wing style sealed to meet NEMA4 / IP65 standards

Installation Notes

Mounting nut max. tightening torque: 10 N·m (88 in·lbf)

Screw Max. tightening torque: 5 N·m (45 in·lbf)

Keys

See page 98

Notes

Wing style suitable for push-to-close action see pages 96 - 97

For lock core selection and a complete overview of the *SOUTHCO*® Key-Choice System see pages 182 - 183

Part Number Selection

Order latch and cam separately

Cam part number see table page 95

Part Number Selection

Order latch and cam separately

Cam part number see table page 95

Wing

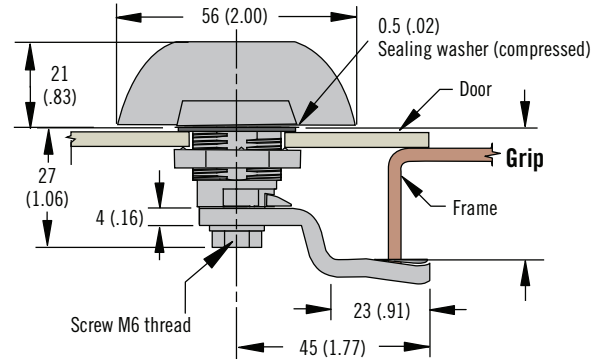
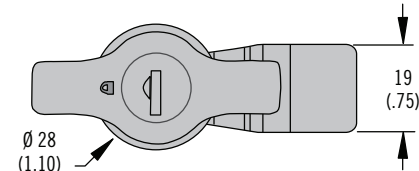

L Lock Styles

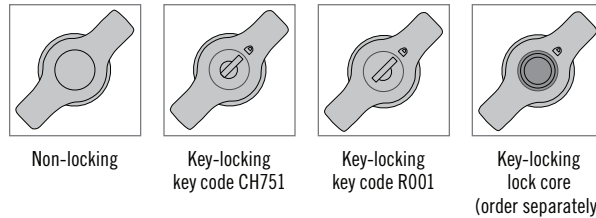

Latch Part Number (no cam)

(no cam)

E5 - 9 - L 5 - UU1 - 1 K

K Key options

- 0 No keys supplied (order separately)
- 3 1 Overmolded key supplied

L Lock style

- 30 Non-locking (omit last two digits of part number)
- 31 Key-locking black lock core keyed alike CH751
- 32 Key-locking stainless steel scalp and shuttered lock core keyed alike R001
- 33 Without lock core (omit last two digits of part number)
Order lock core separately, see pages 182 - 183

Padlockable Wing

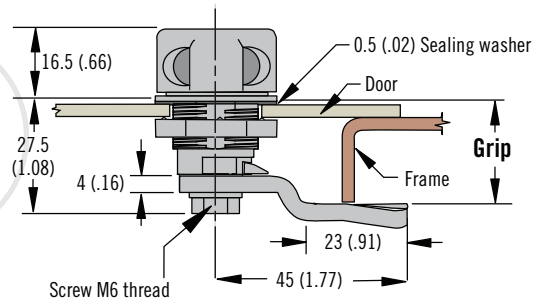
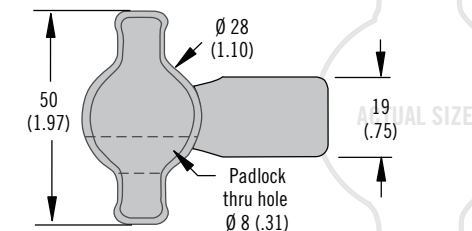

R Rotation

- 1 Type B counter-clockwise to latch
- 2 Type A clockwise to latch

Latch Part Number (no cam)

E5 - 31 - 5 R 2 - UU0

Dimensions in millimeters (inch) unless otherwise stated