

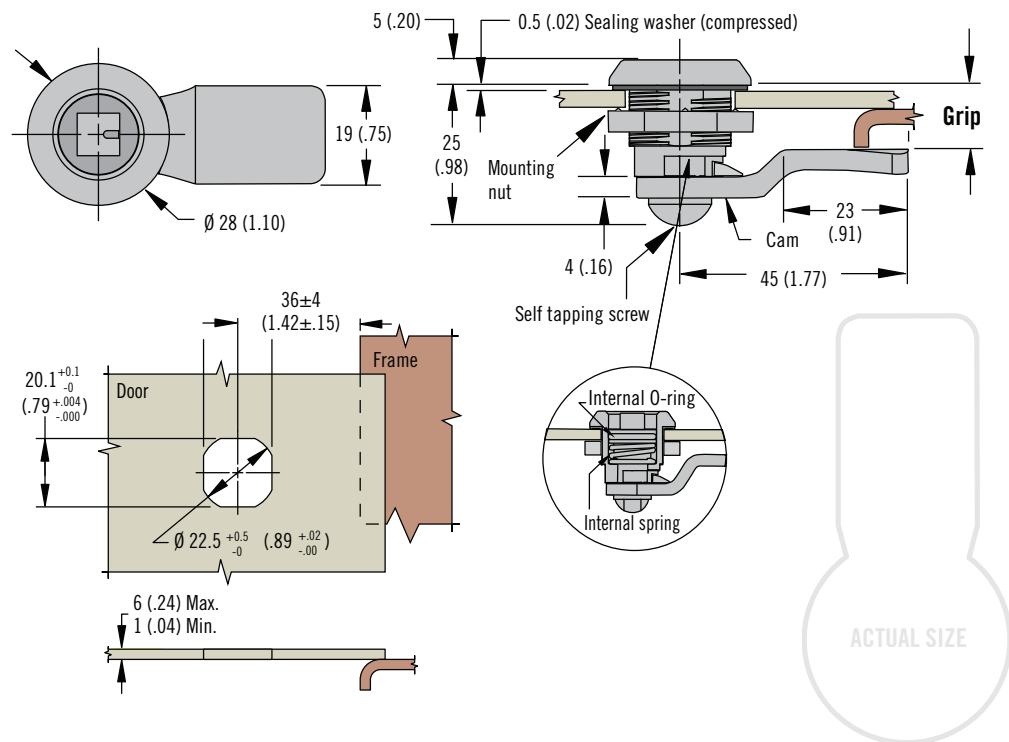

E5 Cam Latch

Glass-filled nylon · Tool operated · Fixed grip



- Single hole install
- Latched / unlatched indicator

Material and Finish
Glass-filled nylon and steel, zinc plated

Performance Details
Max. static load: 300 N (67 lbf)

Installation Notes
Mounting nut:
Max. tightening torque:
4.25 N·m (38 in·lbf)
Screw Max. tightening torque:
3.1 N·m (27 in·lbf)

Keys and Accessories
See pages 98 - 101

H Head Styles

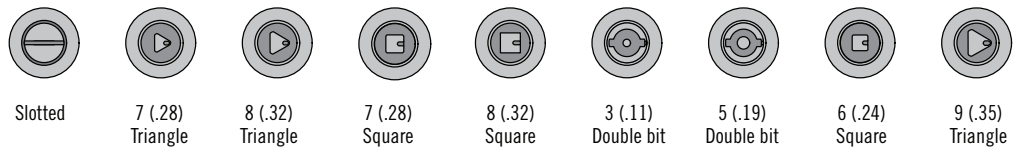

Latch Part Number (no cam) → **E5 - 6 - H 3 - UU1**

H Head style

00 Slotted	05 8 (.32) Square
02 7 (.28) Triangle	06 3 (.11) Double bit
03 8 (.32) Triangle	07 5 (.19) Double bit
04 7 (.28) Square	14 6 (.24) Square
	15 9 (.35) Triangle

Part Number Selection

Order latch and cam separately

Cam Part Number Table (order separately from latch)							
Grip +2(.08) - 0 (.00)	Part Number	Grip +2(.08) - 0 (.00)	Part Number	Grip +2(.08) - 0 (.00)	Part Number	Grip +2(.08) - 0 (.00)	Part Number
4 (.16)	E5-6003	14 (.55)	E5-6008	24 (.94)	E5-6013	34 (1.34)	E5-6018
6 (.24)	E5-6004	16 (.63)	E5-6009	26 (1.02)	E5-6014	36 (1.42)	E5-6019
8 (.31)	E5-6005	18 (.71)	E5-6010	28 (1.10)	E5-6015	38 (1.50)	E5-6020
10 (.39)	E5-6006	20 (.79)	E5-6011	30 (1.18)	E5-6016	40 (1.57)	E5-6021
12 (.47)	E5-6007	22 (.87)	E5-6012	32 (1.25)	E5-6017	42 (1.65)	E5-6022

Dimensions in millimeters (inch) unless otherwise stated