



E3 VISE ACTION® Compression Latch

Stainless steel housing · Tool operated

Compact · Fixed or adjustable grip · 19.1mm size

- Minimal panel intrusion
- Consistent pre-set compression
- Premium finish
- Corrosion resistance
- Tool operated for security
- EN 45545-3 E60 Compliant

Material and Finish

Stainless steel 304 and 316

Performance Details

Compression: 6.4 mm (.25 in)
 Maximum static load:
 Adjustable Grip: 600 N (136 lbf)
 Fixed Grip: 450 N (100 lbf)

Sealing Notes

NEMA 4 and IP65 enabled by using supplied flange gasket

Installation Notes

Recommended tightening torque for the mounting nut is 20 N·m (176 in-lbf)
 Adjustable Grip: Position cam so latching function can be achieved comfortably by hand.
 Fixed Grip: Mounting screw torque 10 N·m (88 in-lbf)

Keys and Accessories

See pages 118-121

FIXED GRIP

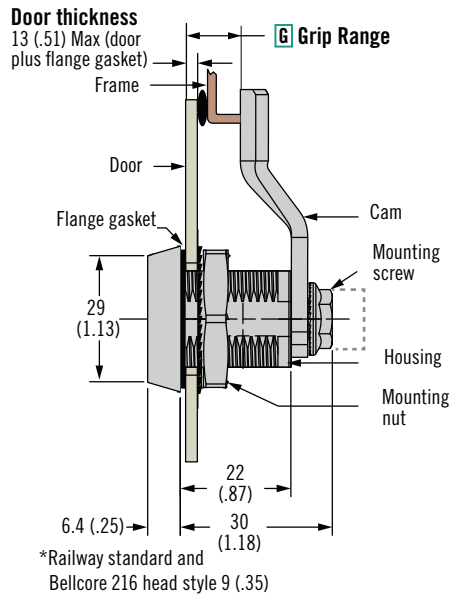

ADJUSTABLE GRIP

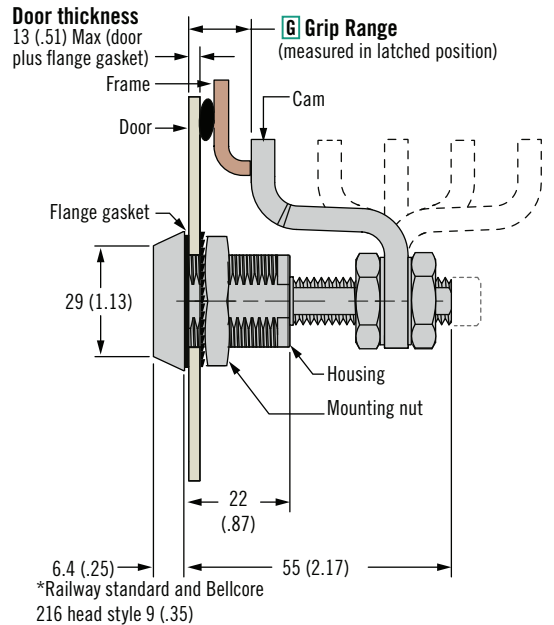

Latch open

Type "A" clockwise to latch

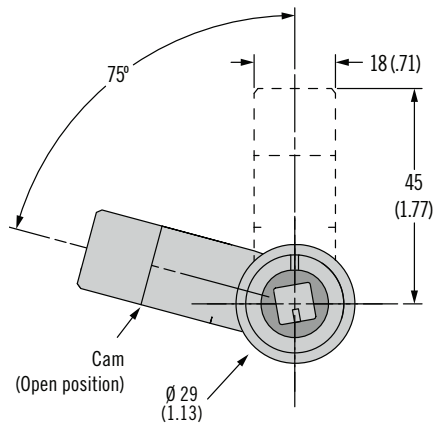

Latch closed

Type "A" clockwise to latch

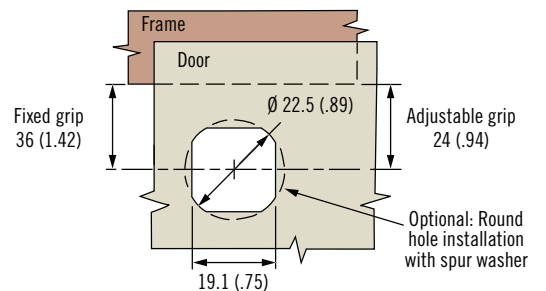
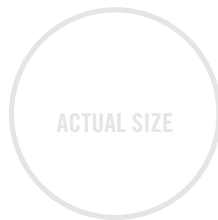
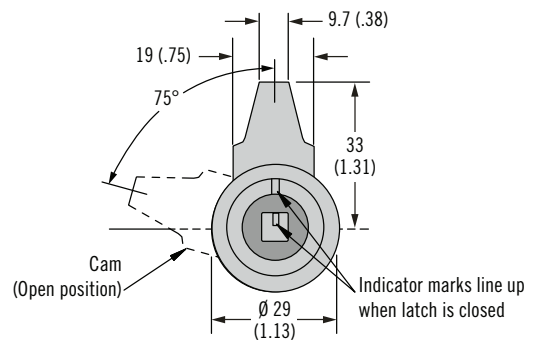

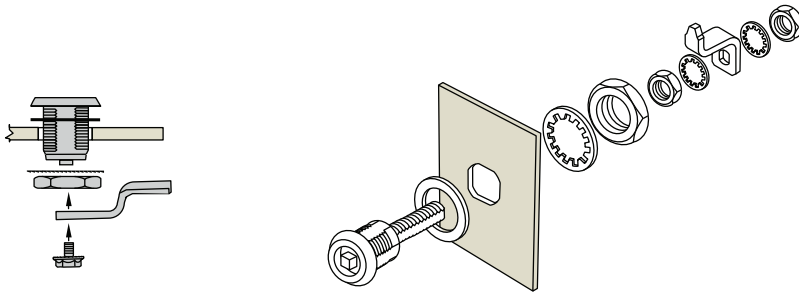

FIXED GRIP

E3 - C R H - UUO

ADJUSTABLE GRIP

E3 - C R H - OO

Part Number Selection

See table
Order latch and cam separately.

H Head Styles

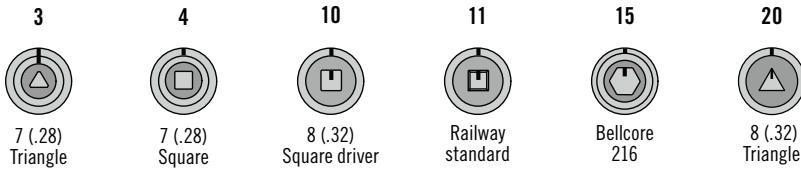

R Rotation

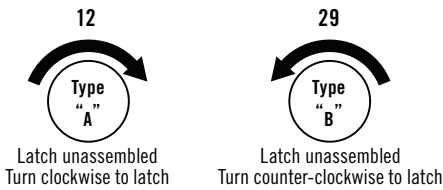

R Rotation

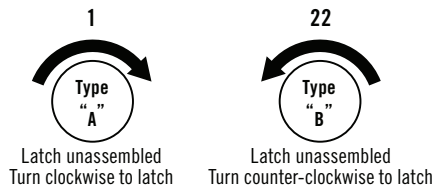

Cam Part Number (order separately from latch)			
Grip	Part Number	Grip	Part Number
4 (.16)	E3-28-700-24	24 (.94)	E3-28-710-24
6 (.24)	E3-28-701-24	26 (1.02)	E3-28-711-24
8 (.31)	E3-28-702-24	28 (1.10)	E3-28-712-24
10 (.39)	E3-28-703-24	30 (1.18)	E3-28-713-24
12 (.47)	E3-28-704-24	32 (1.26)	E3-28-714-24
14 (.55)	E3-28-705-24	34 (1.34)	E3-28-715-24
16 (.63)	E3-28-706-24	36 (1.42)	E3-28-716-24
18 (.71)	E3-28-707-24	38 (1.50)	E3-28-717-24
20 (.79)	E3-28-708-24	40 (1.57)	E3-28-718-24
22 (.87)	E3-28-709-24	42 (1.65)	E3-28-719-24

Cam Part Number Table (order separately from latch)			
Minimum Grip	Maximum Grip	Cam Type	Part Number
3.3 (.13)	14.7 (.58)	Deep offset cam, forward	E3-28-201-24
56.6 (2.23)	66.5 (2.62)	Deep offset cam, reversed	
14.6 (.57)	30.3 (1.19)	Offset cam, forward	E3-28-202-24
42 (1.65)	57.7 (2.27)	Offset cam, reversed	
28.2 (1.13)	44.5 (1.75)	Straight cam	E3-28-203-24

Select grip from Cam table if your grip is between two options choose the smaller grip

