



E3 VISE ACTION® Compression Latch

Zinc and plated steel · Tool or hand operated
Adjustable grip · 19.1mm size

- Consistent pre-set compression
- Easy grip adjustment
- Tool operated for security
- EN 45545-3 E10 Compliant

Material and Finish

Zinc alloy, powder coated or chrome plated and steel, zinc plated

Performance Details

Maximum static load:
450 N (100 lbf)

Sealing Notes

NEMA 4 / IP65 sealing is enabled by using optional flange gasket. Flange gasket part number: E5-17

Installation Notes

Caution: Position cam so latching function can be achieved comfortably by hand. Recommended tightening torque for the mounting nut is 20 N·m (176 in·lbf).

Keys and Accessories

See page 90

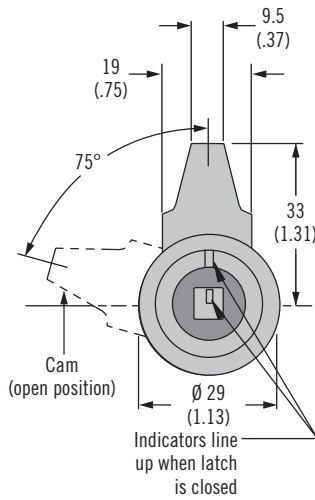

Door thickness

18 (.70) Maximum (door plus flange gasket)

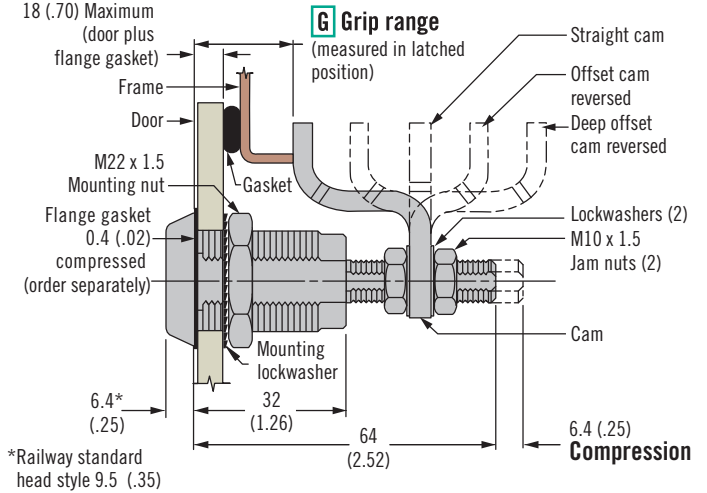

Railway Standard - Bellcore 216

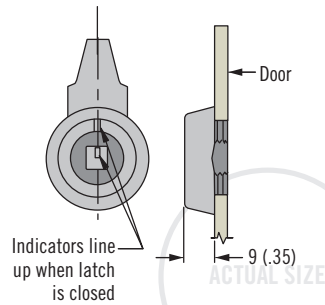

Other Tool Head Styles (slotted recess shown)

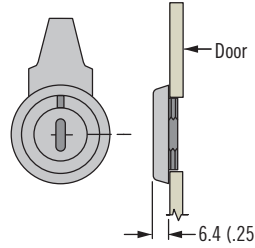

Knob Style

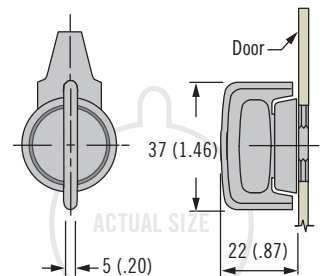

T-Handle Style

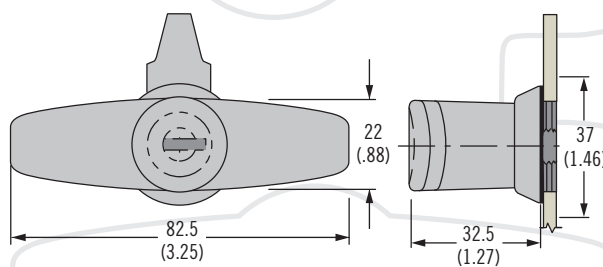

Wing Knob Style

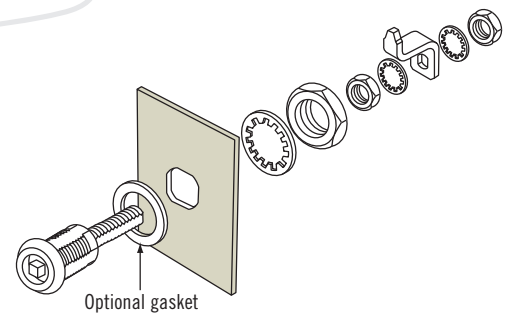
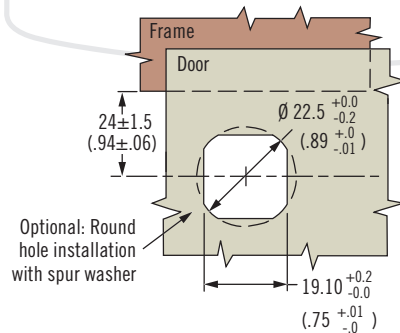
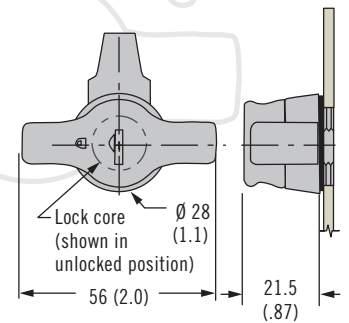

Other options available. For complete details on variety, part numbers, installation and specification, go to

INFO CLIC www.southco.com/E3

Dimensions in millimeters (inch) unless otherwise stated

southco
CONNECT · CREATE · INNOVATE

H Head Styles (other head styles available)

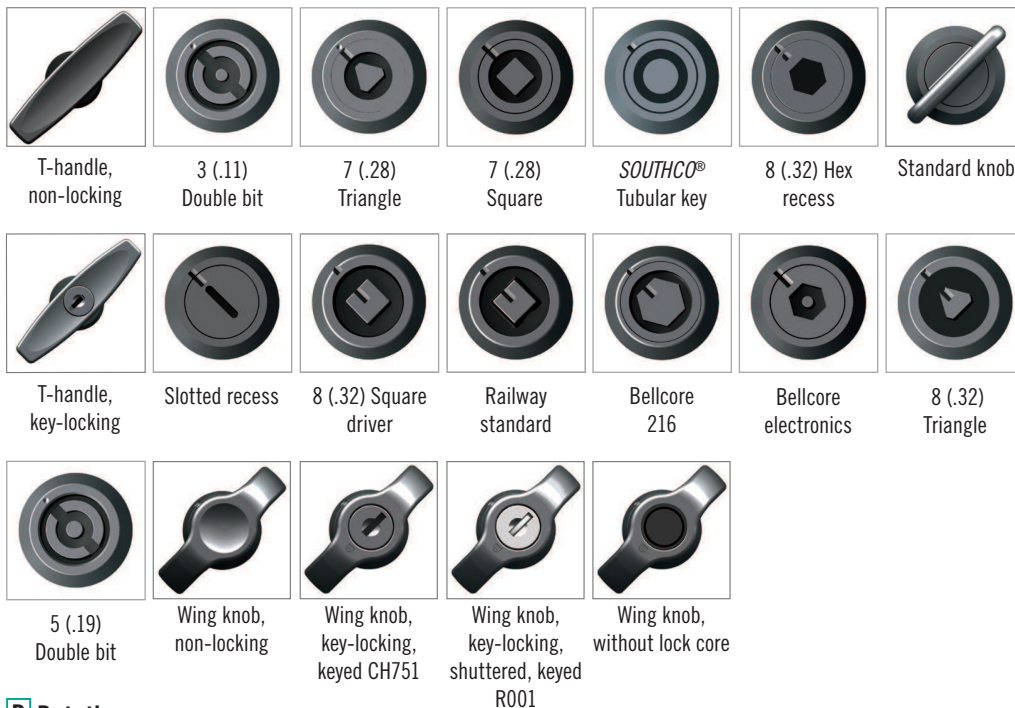

R Rotation

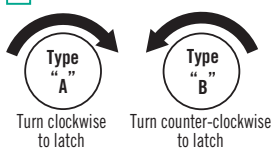

Part Number Selection

See table

E3 - R H - G F

R Rotation

- 1 Type A clockwise to latch
- 22 Type B counter-clockwise to latch

H Head style

- 1 T-handle, non-locking
- 2 3 (.11) Double bit
- 3 7 (.28) Triangle
- 4 7 (.28) Square
- 5 SOUTHCO® Tubular key
- 6 8 (.32) Hex recess
- 7 Standard knob
- 8 T-Handle, key-locking keyed CH751 (two flat keys supplied)
- 9 Slotted recess
- 10 8 (.32) Square driver
- 11 Railway standard
- 15 Bellcore 216
- 16 Bellcore electronics
- 20 8 (.32) Triangle
- 48 5 (.19) Double bit
- 50 Wing knob, non-locking
- 51 Wing knob, key-locking, keyed CH751 (1 overmolded key supplied)
- 58 Wing knob, key-locking, keyed R001 (1 overmolded key supplied)
- 59 Wing knob (no lock)

F Finish

- 1 Chrome plated
- 5 Black powder coated
- 7 Silver powder coated

G Grip	Minimum	Maximum	Cam Type
1	11.4 (.45)	27.2 (1.07)	Deep offset cam, forward
	66.3 (2.61)	76.2 (3.00)	Deep offset cam, reversed
2	25.4 (1)	41.1 (1.62)	Offset cam, forward
	52.6 (2.07)	68.3 (2.69)	Offset cam, reversed
3	38.9 (1.53)	54.6 (2.15)	Straight cam

