



E3 VISE ACTION® Compression Latch

Aluminum housing · Tool operated
Fixed or adjustable grip · 19.1mm size

- Light weight
- Consistent pre-set compression
- Premium finish
- Corrosion resistance
- Tool operated for security
- EN 45545-3 E30 Compliant

Material and Finish

Aluminum, anodized or powder coated
Black hard anodized assembly - Stainless Steel cam and hardware
All other finishes - Steel cam and hardware

Performance Details

Compression: 6.4 mm (.25 in)
Maximum static load: 530 N (120 lbf)
Complies with DIN EN 61373 vibration standard

Sealing Notes

NEMA 4 and IP65 enabled by using supplied flange gasket

Installation Notes

Recommended tightening torque for the mounting nut is 20 N m (176 in lbf).
Position cam so latching function can be achieved comfortably by hand.

Keys and Accessories

See pages 118-121

Part Number Selection

See table.

FIXED GRIP

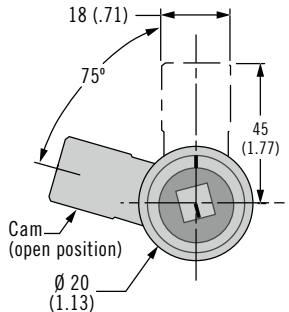
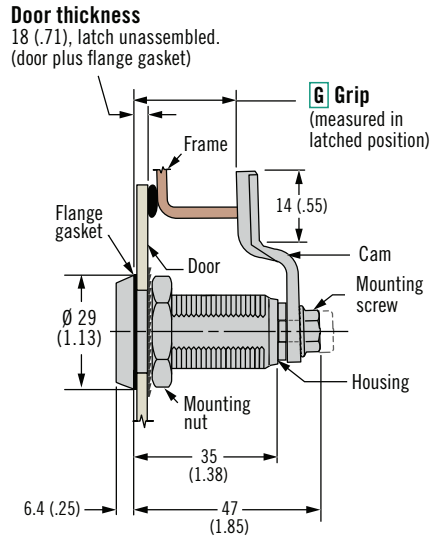

ADJUSTABLE GRIP

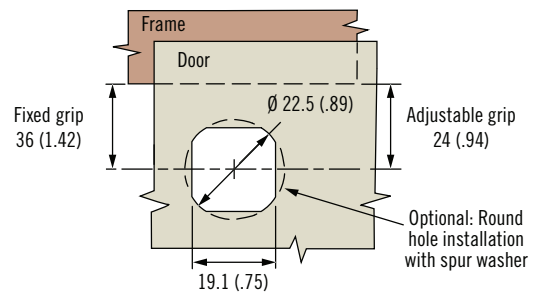
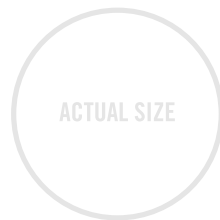
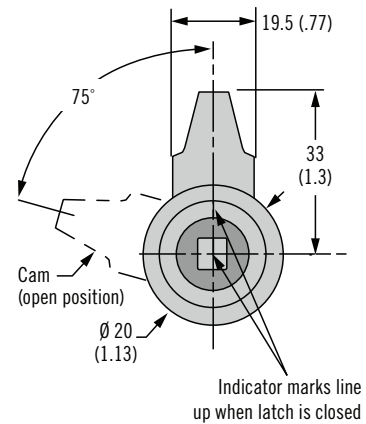
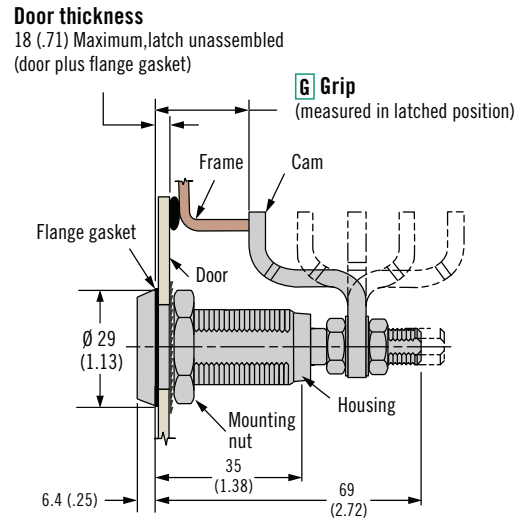

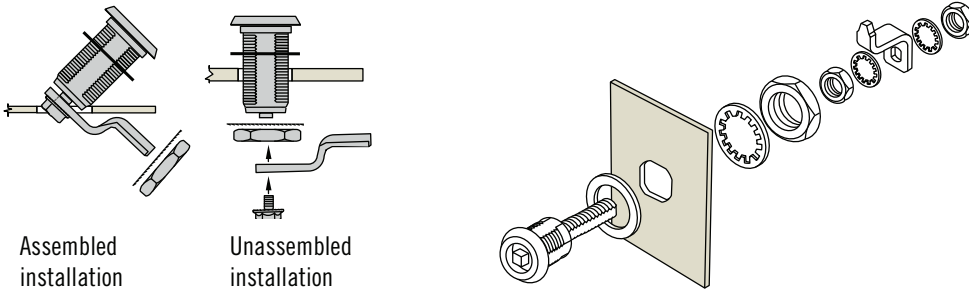

Part Number Selection

E3 - R H - G F

- F Finish**
 59 Black Hard Anodized
 06 Clear Powder Coat
 56 Black Powder Coat
 76 Silver Powder Coat

H Head Styles

- 3



7 (.28)
Triangle
- 4



7 (.28)
Square
- 6



8 (.32) Hex
recess
- 9



Slotted
recess
- 10



8 (.32)
Square driver
- 11



Railway
standard
- 15



Bellcore
216

FIXED GRIP

R Rotation

- 10



Type
"A"

Latch assembled
Turn clockwise to latch
- 12



Type
"A"

Latch unassembled
Turn clockwise to latch
- 27



Type
"B"

Latch assembled
Turn counter-clockwise to latch
- 29



Type
"B"

Latch unassembled
Turn counter-clockwise to latch

ADJUSTABLE GRIP

R Rotation

- 1

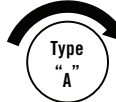

Type
"A"

Latch unassembled
Turn clockwise to latch
- 22

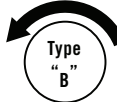

Type
"B"

Latch unassembled
Turn counter-clockwise to latch

G Grip Table

Total Grip	G	Max. Door Thickness for Assembled Latch	Total Grip	G	Max. Door Thickness for Assembled Latch
20 (.79)	00	1 (.04)	40 (1.57)	10	7 (.28)
22 (.87)	01	2 (.08)	42 (1.65)	11	
24 (.94)	02	4 (.16)	44 (1.73)	12	
26 (1.02)	03	5 (.20)	46 (1.81)	13	
28 (1.10)	04	6 (.24)	48 (1.89)	14	
30 (1.18)	05		50 (1.97)	15	
32 (1.25)	06		52 (2.05)	16	
34 (1.34)	07		54 (2.13)	17	
36 (1.42)	08		56 (2.20)	18	
38 (1.50)	09		58 (2.28)	19	

For Fixed Grip, if your grip is between two options choose the smaller grip

G Grip	Minimum	Maximum	Cam Type
1	16.4 (.64)	32.2 (1.26)	Deep offset cam, forward
	71.3 (2.80)	81.2 (3.19)	Deep offset cam, reversed
2	30.4 (1.19)	46.1 (1.81)	Offset cam, forward
	57.6 (2.26)	73.3 (2.88)	Offset cam, reversed
3	43.9 (1.72)	59.6 (2.34)	Straight cam