



E3 VISE ACTION® Compression Latch

Metal injection molding stainless steel housing · Tool or hand operated
Adjustable grip · 19.1mm size

- Consistent pre-set compression
- Easy grip adjustment
- Tool or hand operated
- EN 45545-3 E60 Compliant

Material and Finish

Stainless steel 316 and 304

Performance Details

Maximum static load:
556 N (125 lbf)

Sealing Notes

NEMA 4 and IP65 enabled using gasket supplied

Installation Notes

Caution: Position cam so latching function can be achieved comfortably by hand.

Recommended tightening torque for the mounting nut is 20 N·m (176 in·lbf).

Keys and Accessories

See page 90

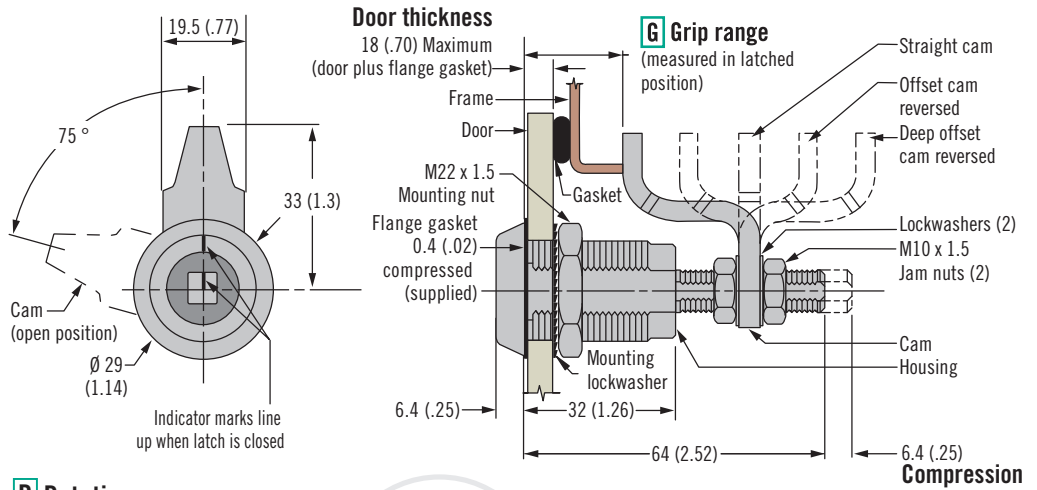

R Rotation

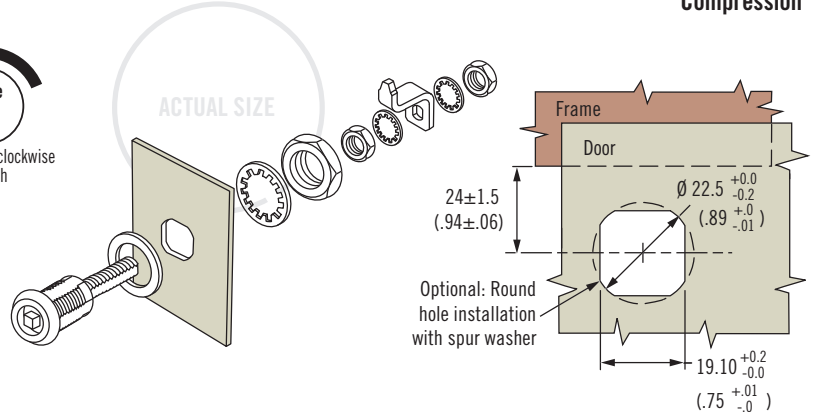
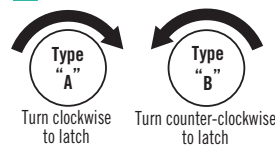

H Head Styles

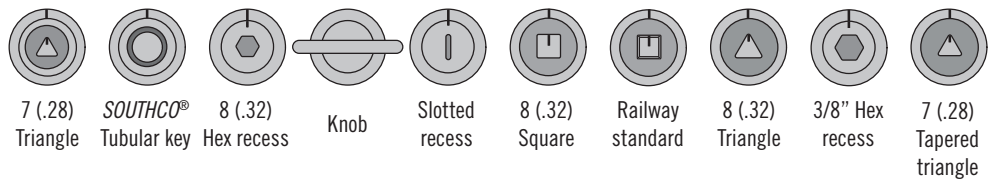

Part Number Selection

See table

E3 - R H - G F		G Grip	Minimum	Maximum	Cam Type
1	Type A clockwise to latch	1	11.4 (.45)	27.2 (1.07)	Deep offset cam, forward
			66.3 (2.61)	76.2 (3.00)	Deep offset cam, reversed
22	Type B counter-clockwise to latch	2	25.4 (1.00)	41.1 (1.62)	Offset cam, forward
			52.6 (2.07)	68.3 (2.69)	Offset cam, reversed
3	7 (.28) Triangle	3	38.9 (1.53)	54.6 (2.15)	Straight cam

R Rotation	F Finish
1 Type A clockwise to latch	2 Electropolished
22 Type B counter-clockwise to latch	12 Electropolished and hand buffed (bright)

H Head style	10 8 (.32) Square
3 7 (.28) Triangle	11 Railway standard
5 SOUTHCO® Tubular key	20 8 (.32) Triangle
6 8 (.32) Hex recess	37 3/8" Hex recess
7 Knob	39 7 (.28) Tapered triangle
9 Slotted recess	

Dimensions in millimeters (inch) unless otherwise stated

Other options available. For complete details on variety, part numbers, installation and specification, go to

INFO GLIC www.southco.com/E3