



E3 VISE ACTION® Compression Latch

Large · Zinc and plated steel · Hand operated · Adjustable grip

- Consistent pre-set compression
- Easy grip adjustment
- Hand operated

Material and Finish

Zinc alloy, powder coated or chrome plated and steel, zinc plated

Performance Details

Max. static load: 450 N (100 lbf)

Sealing Notes

NEMA 4 / IP65 sealing is achieved by using optional flange gasket. Flange gasket part number: E5-17

Installation Notes

Caution: Position cam so latching function can be achieved comfortably by hand. Recommended tightening torque for the mounting nut is 20 N·m (176 in·lbf).

Keys and Accessories

Key CH751 page 58
Washers and sleeve nut see page 60

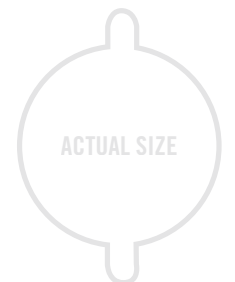
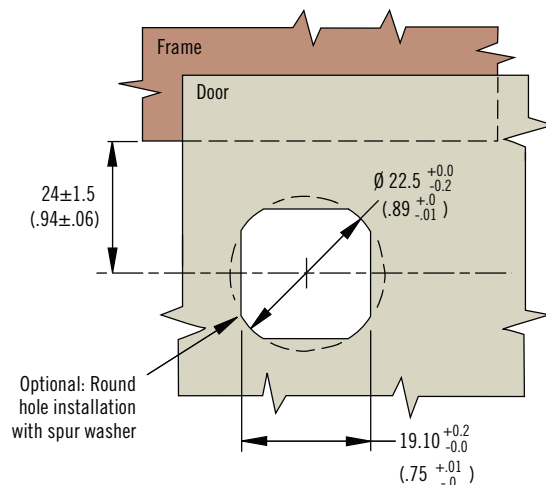
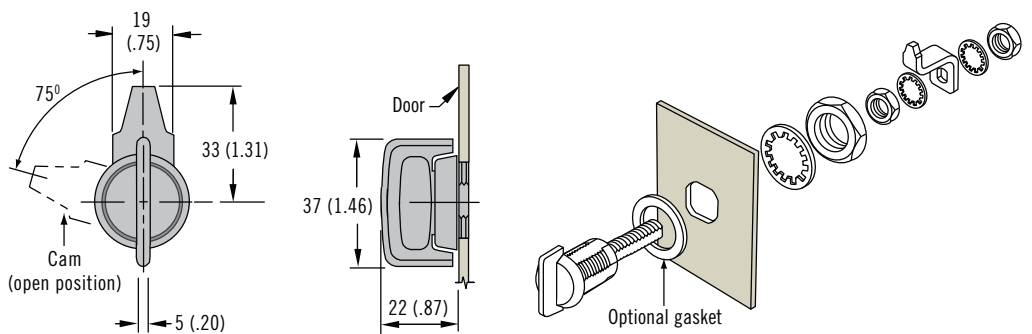
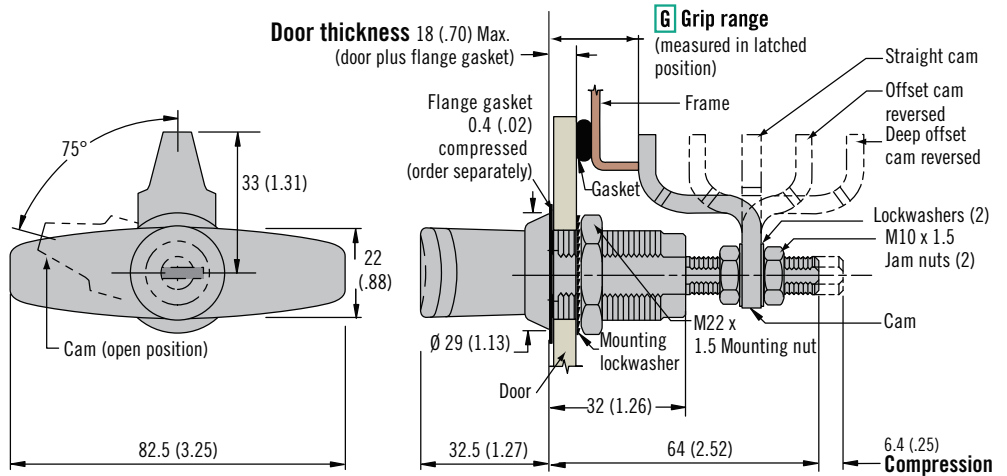

Dimensions in millimeters (inch) unless otherwise stated

H Head Styles



Standard knob



T-handle, key-locking



T-handle, non-locking

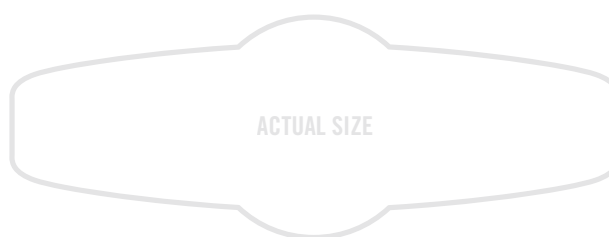

Part Number Selection

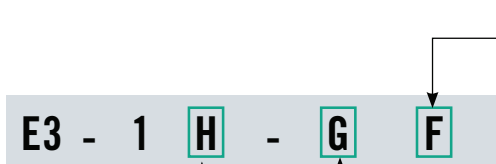

- F** Finish
- 1 Chrome plated
 - 5 Black powder coated
 - 7 Silver powder coated

- H** Head style
- 1 T-handle, non-locking
 - 7 Standard knob
 - 8 T-Handle, key-locking keyed CH751 (two flat keys supplied)

G Grip	Min.	Max.	Cam Type
1	11.4 (.45)	27.2 (1.07)	Deep offset cam, forward
	66.3 (2.61)	76.2 (3.00)	Deep offset cam, reversed
2	25.4 (1)	41.1 (1.62)	Offset cam, forward
	52.6 (2.07)	68.3 (2.69)	Offset cam, reversed
3	38.9 (1.53)	54.6 (2.15)	Straight cam

