

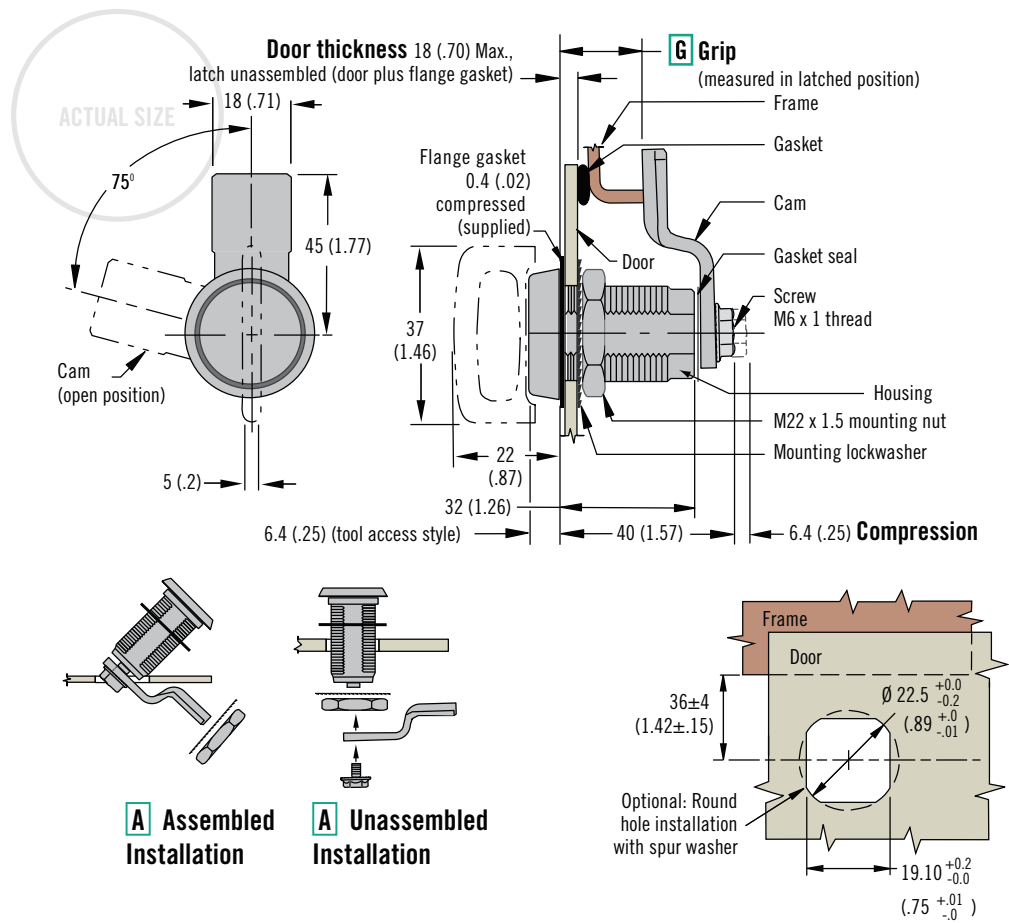

# E3 VISE ACTION® Compression Latch

Large · Metal injection molding stainless steel housing · Fixed grip



- Consistent pre-set compression
- Tool or hand operated
- Reduced internal protrusion

**Material and Finish**  
Stainless steel 316 and 304

**Performance Details**  
Max. static load: 445 N (100 lbf)

**Sealing Notes**  
NEMA 4 / IP65 achieved using gasket supplied

**Installation Notes**  
Recommended tightening torque for the mounting nut is 20 N·m (176 in·lbf), and for the mounting screw in 10 N·m (88 in·lbf)

**Keys and Accessories**  
See pages 58 - 61

**Part Number Selection**  
Select grip from table, if your grip is between two options choose smaller.

**H Head style**

- 5 SOUTHCO® Tubular key
- 6 8 (.32) Hex recess
- 7 Knob
- 9 Slotted recess
- 10 8 (.32) Square
- 11 Railway standard
- 20 8 (.32) triangle
- 37 3/8" Hex recess
- 39 7 (.28) Tapered triangle

**A Assembly status**

- 10 Assembled
- 12 Unassembled

**F Finish**

- 2 Electropolished
- 12 Electropolished and hand buffed (bright)

**E3 - A H - G F**

Grip Table											
Total Grip	G	Max. Door Thickness for Assembled Latch	Total Grip	G	Max. Door Thickness for Assembled Latch	Total Grip	G	Max. Door Thickness for Assembled Latch	Total Grip	G	Max. Door Thickness for Assembled Latch
15 (.59)	00	Use unassembled	25 (.98)	05	5 (.20)	35 (1.38)	10	7 (.28)	45 (1.77)	15	7 (.28)
17 (.67)	01	Use unassembled	27 (1.06)	06	6 (.24)	37 (1.46)	11		47 (1.85)	16	
19 (.75)	02	1 (.04)	29 (1.14)	07	7 (.28)	39 (1.53)	12		49 (1.93)	17	
21 (.83)	03	2 (.08)	31 (1.22)	08		41 (1.61)	13		51 (2.01)	18	
23 (.91)	04	4 (.16)	33 (1.30)	09		43 (1.69)	14		53 (2.09)	19	



Dimensions in millimeters (inch) unless otherwise stated

