

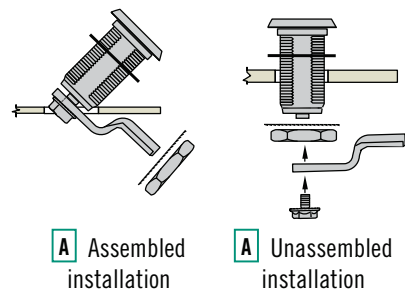

# E3 VISE ACTION® Compression Latch

Large · Machined stainless steel housing · Tool operated · Fixed grip

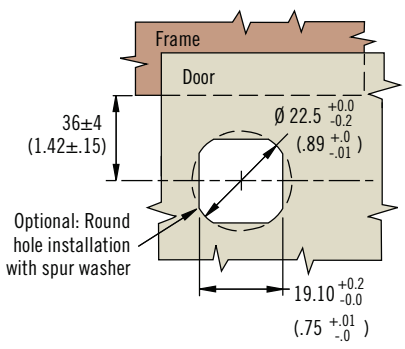
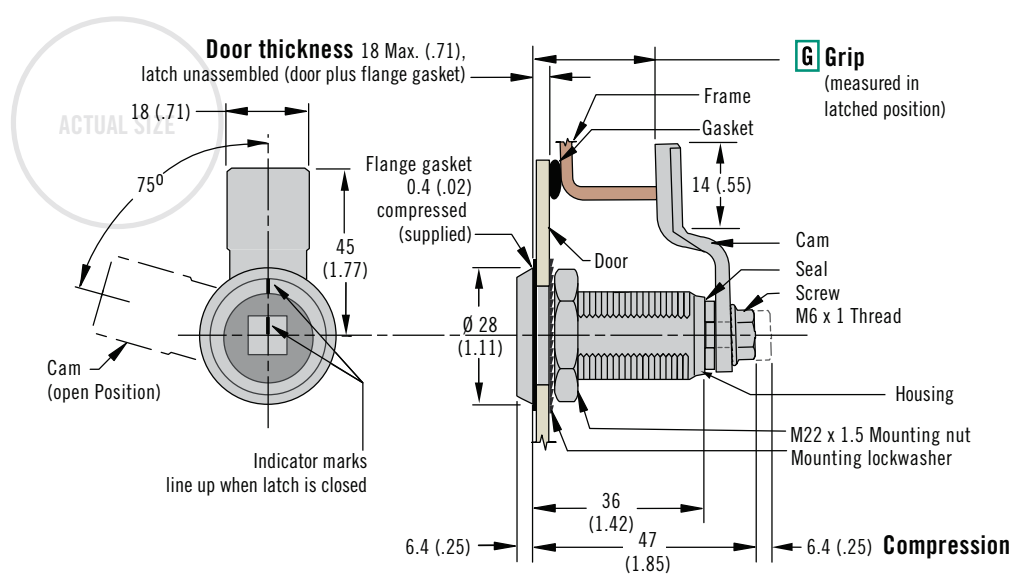

- Consistent pre-set compression
- Premium finish and corrosion resistance
- Reduced internal protrusion

**Material and Finish**  
Stainless steel (304 and 316 machined)

**Performance Details**  
Max. static load: 450 N (102 lbf)

**Sealing Notes**  
NEMA 4 and IP65 achieved using gasket supplied

**Keys and Accessories**  
See pages 58 - 61

**Installation Notes**  
Recommended tightening torque for the mounting nut is 20 N·m (176 in·lbf), and for the mounting screw is 10 N·m (88 in·lbf)

**Part Number Selection**

Select grip from table, if your grip is between two options choose smaller.

- H Head style**
- 2 3 (.11) Double bit
  - 3 7 (.28) Triangle
  - 4 7 (.28) Square
  - 5 SOUTHCO® Tubular key
  - 6 8 (.32) Hex recess
  - 9 Slotted recess
  - 10 8 (.32) Square
  - 11 Railway standard
  - 15 Bellcore 216

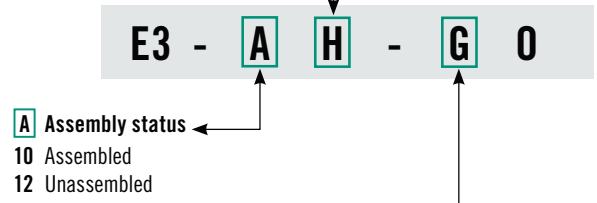

**G Grip Table**

Total Grip	G	Max. Door Thickness for Assembled Latch	Total Grip	G	Max. Door Thickness for Assembled Latch	Total Grip	G	Max. Door Thickness for Assembled Latch	Total Grip	G	Max. Door Thickness for Assembled Latch
20 (.79)	00	1 (.04)	30 (1.18)	05	7 (.28)	40 (1.57)	10	7 (.28)	50 (1.97)	15	7 (.28)
22 (.87)	01	2 (.08)	32.5 (1.28)	06		42 (1.65)	11		52 (2.05)	16	
24 (.94)	02	4 (.16)	34 (1.34)	07		44 (1.73)	12		54 (2.13)	17	
26 (1.02)	03	5 (.20)	36 (1.42)	08		46 (1.81)	13		56 (2.20)	18	
28 (1.10)	04	6 (.24)	38 (1.50)	09		48 (1.89)	14		58 (2.28)	19	



Dimensions in millimeters (inch) unless otherwise stated

