

DM Inserts

MonoSert rack attach

- Front install insert for rack attach applications

Material and Finish

Steel, zinc plated

Installation Notes

Max. tightening torque:
2 N•m (17.7 in•lbf)

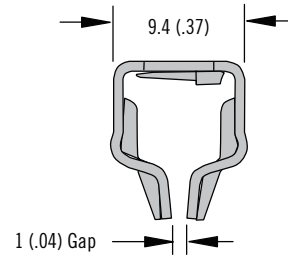
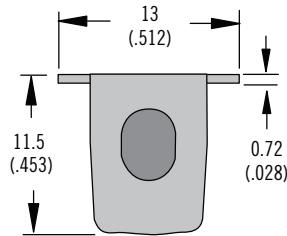
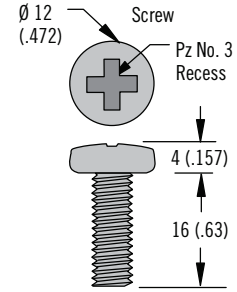
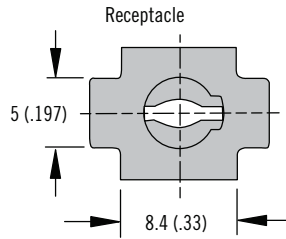

Standard Installation

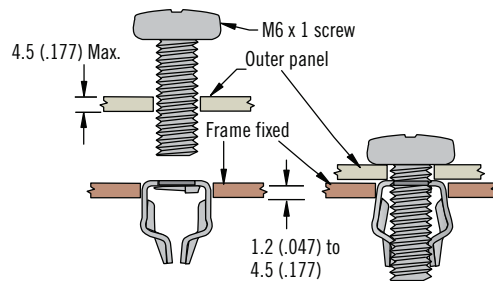

Alternative Installation

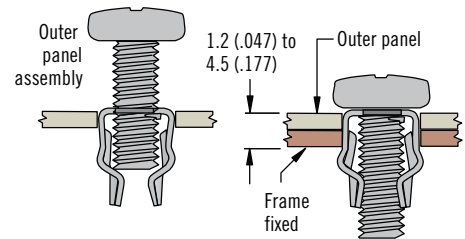

Part Number

See table

Part Number
DM-10-10216-10

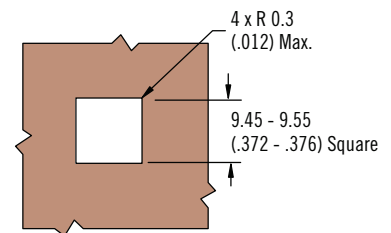

Other options available. For complete details on variety, part numbers, installation and specification, go to



Dimensions in millimeters (inch) unless otherwise stated

DM Inserts

DuoSert rack attach

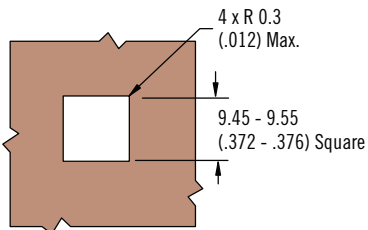
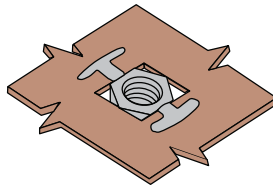
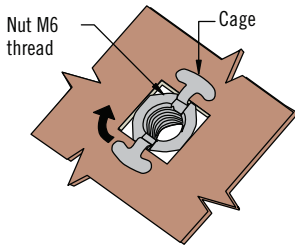
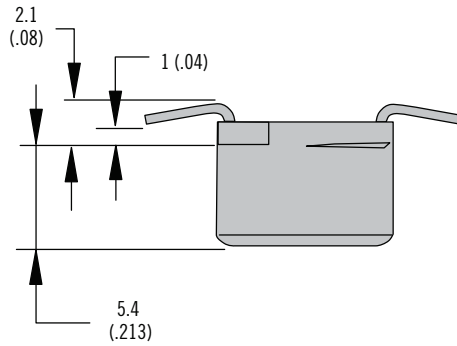
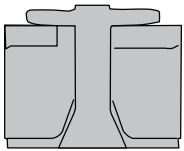
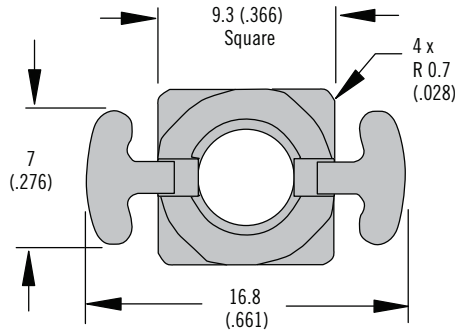

Part Number
DM-95-10-12-11

Receptacle only. (Screw not supplied)

• Front install insert for rack attach applications

Material and Finish

Zinc alloy and stainless steel, natural

Installation Notes

Max. tightening torque:

10 N•m (88.5 in•lbf)

Max. panel thickness:

1 - 1.2 (.039 - .047)

Recommended installation tool requires a flat blade screwdriver

Part Number

See table

