

D8-316-H K-200

REVISION HISTORY			
REV	DATE	BY	DESCRIPTION
E	13JUL2016	RNG/YGC	PRN: P2016-1639

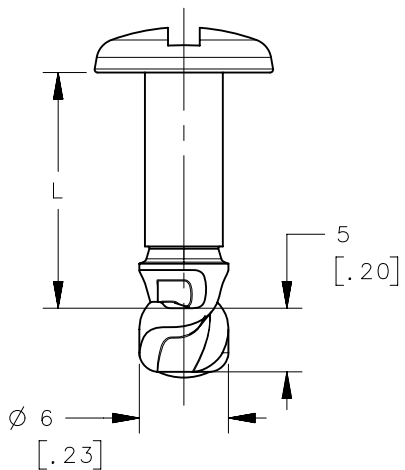

H-HEAD STYLE OPTIONS
 1-SLOTTED
 2-HEX RECESS
 7-PHILLIPS RECESS

K-STUD 'L' DIMENSIONS

K	'L'
	±.15 [.006]
08	8.0 [.32]
09	9.0 [.35]
10	10.0 [.39]
11	11.0 [.43]
12	12.0 [.47]
13	13.0 [.51]
14	14.0 [.55]
15	15.0 [.59]
16	16.0 [.63]
17	17.0 [.67]
18	18.0 [.71]
19	19.0 [.75]
20	20.0 [.79]
21	21.0 [.83]
22	22.0 [.87]
23	23.0 [.90]
24	24.0 [.94]
25	25.0 [.98]
26	26.0 [1.02]
27	27.0 [1.06]
28	28.0 [1.10]
29	29.0 [1.14]
30	30.0 [1.18]
31	31.0 [1.22]
32	32.0 [1.26]
33	33.0 [1.30]
34	34.0 [1.34]
35	35.0 [1.38]
36	36.0 [1.42]
37	37.0 [1.46]
38	38.0 [1.50]

SLOTTED	HEX RECESS	NO.3 PHILLIPS RECESS
ORIENTED WITH CAM	NOT ORIENTED WITH CAM	NOT ORIENTED WITH CAM

D8-316-XXX-200	STAINLESS STEEL	NONE	SEE NOTE 3
PART NUMBER	MATERIAL	HEAT TREATMENT	FINISH
THIRD ANGLE PROJECTION		 CONNECT • CREATE • INNOVATE	
MILLIMETERS [IN]			
TOLERANCES UNLESS OTHERWISE NOTED		DESCRIPTION PANEX QUARTER-TURN SIZE 6 STUD	
ALL DIMENSIONS WITHOUT TOLERANCES ARE FOR REFERENCE ONLY.		SIZE A4	SYSTEM NX
PROPRIETARY ITEM <small>EXCEPT FOR USES EXPRESSLY GRANTED IN WRITING, INFORMATION DISCLOSED HEREON IS CONFIDENTIAL AND ALL RIGHTS, PATENT AND OTHERWISE, ARE RESERVED BY SOUTHCO, INC.</small>		DWG NO. J-D8-316-XXX-200	
PER ASME Y14.5M-1994		DRAWN BY DMS/YGC	DATE 26MAR2012
		SCALE 2:1	SHEET 1 OF 1

- NOTES:
- PANEL PREPARATION Ø 7.2 [.28]/7.0 [.27].
 - STUD PART NUMBER D8-316-122-200 SHOWN.
 - FINISH: DRY FILM TOPCOAT WITH LUBRICANT.