

# PART NUMBER EXPLANATION

## D8-316-8LL-1XX

REVISION HISTORY			
REV	DATE	BY	DESCRIPTION
B	16APR2013	MWC/YGC	PRN: P2013-0882

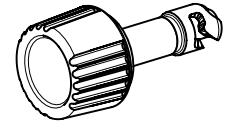

SCALE 1:1

LL	'L' ±.15 [.006]
08	8.0 [.32]
09	9.0 [.35]
10	10.0 [.39]
11	11.0 [.43]
12	12.0 [.47]
13	13.0 [.51]
14	14.0 [.55]
15	15.0 [.59]
16	16.0 [.63]
17	17.0 [.67]
18	18.0 [.71]
19	19.0 [.75]
20	20.0 [.79]
21	21.0 [.83]
22	22.0 [.87]
23	23.0 [.90]
24	24.0 [.94]
25	25.0 [.98]
26	26.0 [1.02]
27	27.0 [1.06]
28	28.0 [1.10]
29	29.0 [1.14]
30	30.0 [1.18]
31	31.0 [1.22]
32	32.0 [1.26]
33	33.0 [1.30]
34	34.0 [1.34]
35	35.0 [1.38]
36	36.0 [1.42]
37	37.0 [1.46]
38	38.0 [1.50]
39	39.0 [1.54]
40	40.0 [1.57]
41	41.0 [1.61]
42	42.0 [1.65]
43	43.0 [1.69]
44	44.0 [1.73]
45	45.0 [1.77]
46	46.0 [1.81]
47	47.0 [1.85]

STUD 'L' DIMENSIONS

STUD FINISH OPTIONS  
 121-SILVER GEOMET  
 130-DELTA PROTEKT SILVER  
 131-DELTA PROTEKT BLACK  
 170-BRIGHT CHROME  
 151-BLACK XYLAN XL  
 190-BRIGHT ZINC PLATE  
 191-BLACK ZINC PLATE

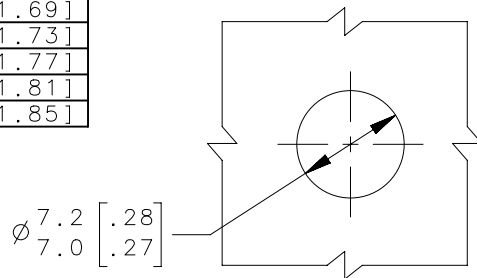
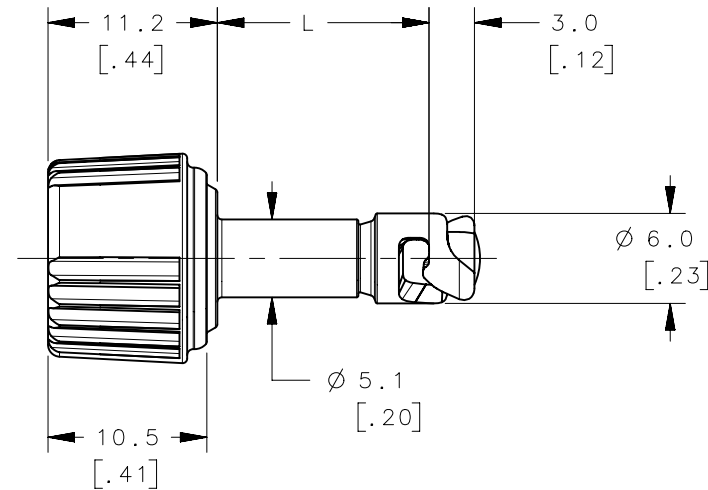
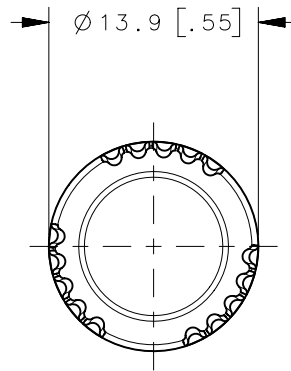

PANEL PREPARATION

D8-316-8LL-1XX		STUD	CASE HARDENED STEEL	SEE PART NUMBER EXPLANATION
PART NUMBER		TYPE OF COMPONENT	MATERIAL	FINISH
THIRD ANGLE PROJECTION		 <b>southco</b> <sup>®</sup> CONNECT • CREATE • INNOVATE		
MILLIMETERS [IN]				
TOLERANCES UNLESS OTHERWISE NOTED				
ALL DIMENSIONS WITHOUT TOLERANCES ARE FOR REFERENCE ONLY.				
PROPRIETARY ITEM		DESCRIPTION		
EXCEPT FOR USES EXPRESSLY GRANTED IN WRITING, INFORMATION DISCLOSED HEREON IS CONFIDENTIAL AND ALL RIGHTS, PATENT AND OTHERWISE, ARE RESERVED BY SOUTHCO, INC.		SNAP-ON KNOB HEAD STUD		
PER ASME Y14.5M-1994		SIZE	SYSTEM	DWG NO.
		A4	NX	J-D8-316-8
		DRAWN BY	DATE	SCALE
		MWC/YGC	14AUG2012	2:1
				SHEET
				1 OF 1