



D7 DZUS® Pilot Quarter-Turn Fasteners

Studs

Material and Finish

Studs: Steel, zinc plated plus chromate

Washer: Neoprene, black

Notes

Select stud and washer part number from table based on your panel thickness **P**

Part Number

See table

Order stud and washer separately

Studs

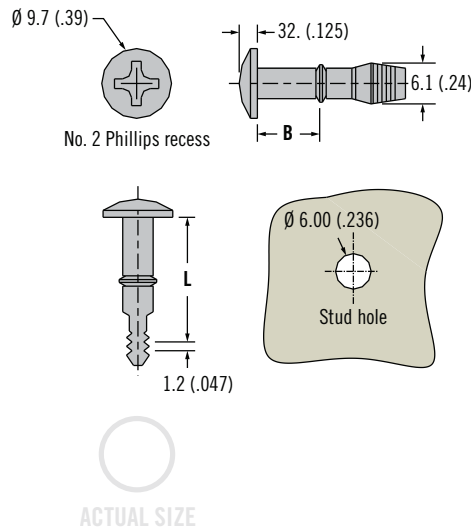

Washer

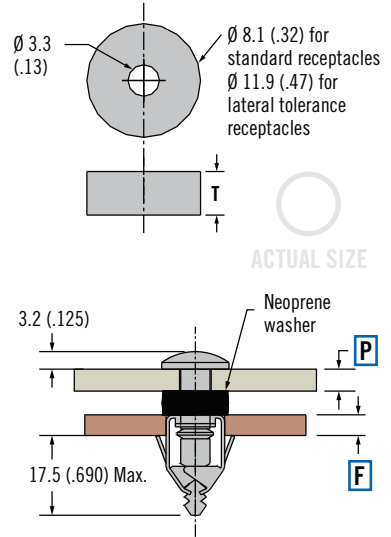

Panel Thickness P	Stud L	Stud B	T Washer Thickness	Part Number			
				Stud		Neoprene Washer	
				Black chromate	Bright chromate	For standard receptacle	For lateral tolerance receptacle
1.3 (.05) to 1.7 (.07)	16 (.63)	7.1 (.28)	4.1 (.16)	D7-265-716-191	D7-265-716-190	D7-275-040-400	D7-275-140-400
1.8 (.07) to 2.2 (.09)	16 (.63)	7.1 (.28)	3.6 (.14)	D7-265-716-191	D7-265-716-190	D7-275-035-400	D7-275-135-400
2.3 (.09) to 2.7 (.11)	17.8 (.70)	8.9 (.35)	5.1 (.20)	D7-265-718-191	D7-265-718-190	D7-275-050-400	D7-275-150-400
2.8 (.11) to 3.2 (.12)	17.8 (.70)	8.9 (.35)	4.6 (.18)	D7-265-718-191	D7-265-718-190	D7-275-045-400	D7-275-145-400
3.3 (.13) to 3.7 (.15)	17.8 (.70)	8.9 (.35)	4.1 (.16)	D7-265-718-191	D7-265-718-190	D7-275-040-400	D7-275-140-400
3.8 (.15) to 4.2 (.17)	17.8 (.70)	8.9 (.35)	3.6 (.14)	D7-265-718-191	D7-265-718-190	D7-275-035-400	D7-275-135-400
4.3 (.17) to 4.8 (.19)	20.0 (.79)	10.9 (.43)	5.1 (.20)	D7-265-720-191	D7-265-720-190	D7-275-050-400	D7-275-150-400

Material and Finish

Steel, zinc plated and thermoplastic black

Notes

Select stud and washer part number from table based on your panel thickness **P**

Part Number

See table

Stud, cup and spring shipped pre-assembled

Order retainer separately

Self-Ejecting Studs

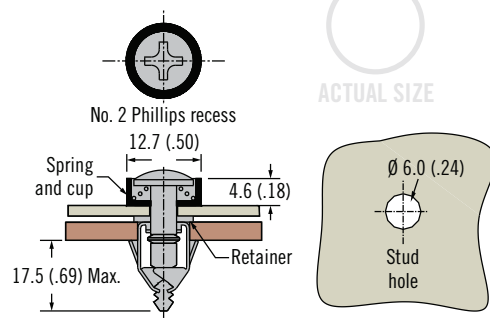

Retainer, Plastic

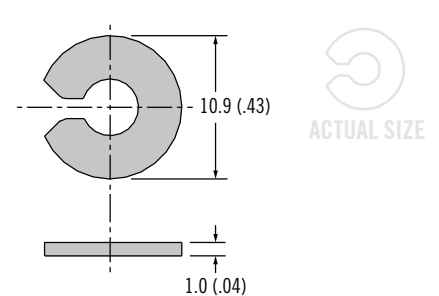

Panel Thickness P	Part Number	
	Black	Bright
0.5 - 3.0 (.02 - .12)	D7-290-718-191	D7-290-718-190
2.5 - 5.1 (.10 - .20)	D7-290-720-191	D7-290-720-190

Part Number
D7-275-203-040

D7 DZUS® Pilot Quarter-Turn Fasteners Receptacles



Standard

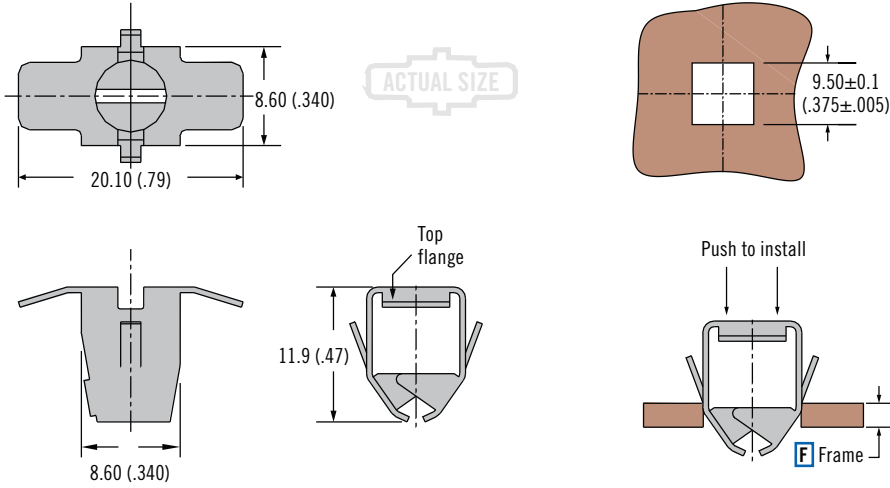

Material and Finish

Spring steel, zinc phosphate

Notes

Select receptacle based on frame thickness **F**

82

85

D8

D1

D4

D7

NY



Part Number

See table

Lateral Tolerance

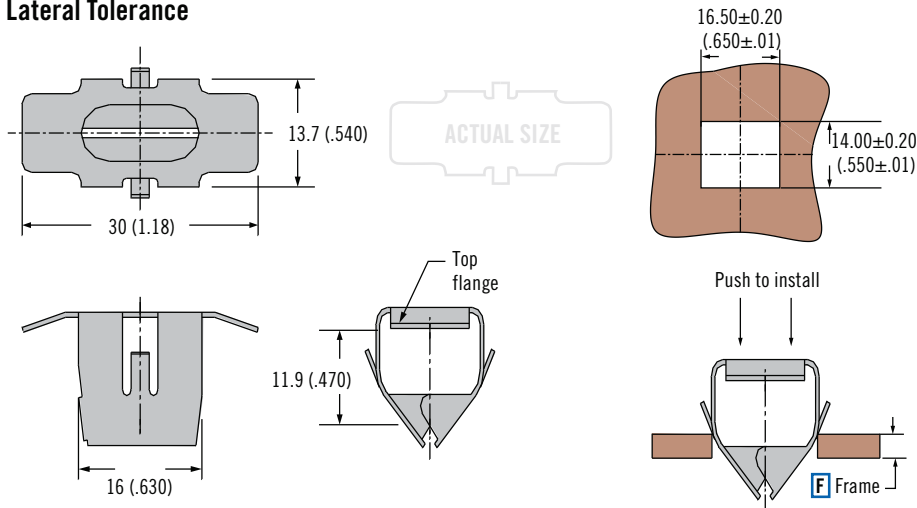

Material and Finish

Spring steel, zinc phosphate

Notes

Select receptacle based on frame thickness **F**

Part Number

See table



D7 DZUS® Arrow Quarter-Turn Fasteners Assembly

- Surface install
- Panel mounted assembly

Material and Finish

Acetal, black

Performance Details

Flammability rating: UL94-HB

ASTM E-162 Flame spread Index:

130

D7 Arrow Installation notes

200 series:

1. Press receptacle into outer panel.
2. Press stud into receptacle.
3. Press and turn stud to latch
4. Turn stud 90 degree to unlatch.

2000 series:

1. Separate Stud and receptacle from runner.
2. Press receptacle into outer panel.
3. Press stud into receptacle.
4. Press and turn stud to latch
5. Turn stud 90 degree to unlatch

Part Number

See table

200 Series: Order one receptacle and stud from the same size separately

2001 Series: Complete assembly supplied with runner attached as shown

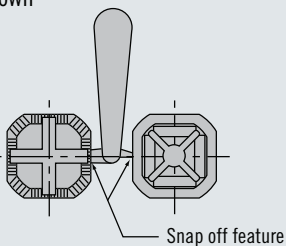

200 Series (order stud and receptacle separately)

Locked

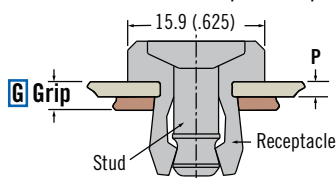

Released

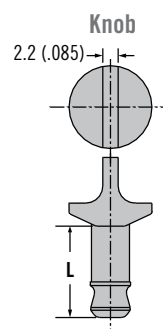
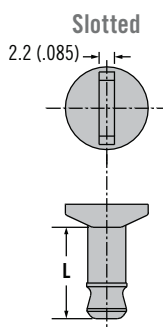
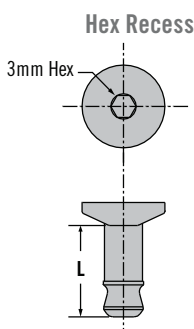
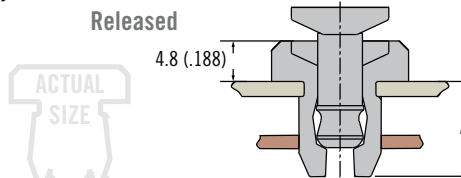

2001 Series

Latched

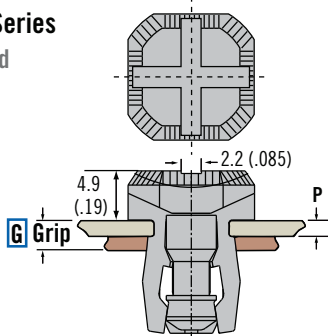

Unlatched

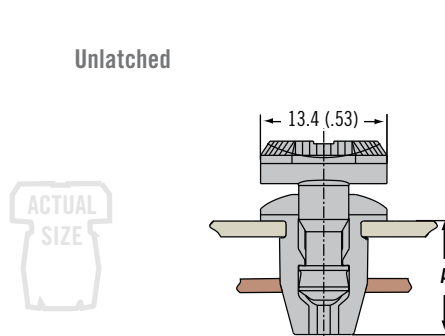

Installation

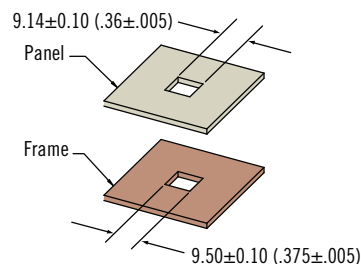
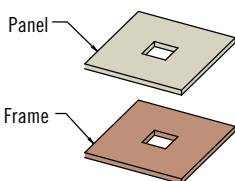

Series	A	Receptacle			Stud				
		Panel Thickness		Part Number	Grip Range		Part Number		
		Min.	Max.		Min.	Max.	Hex recess	Slotted recess	Knob
200	12.3 (.48)	0.50 (.020)	1.78 (.070)	D7-200-802-010	2.03 (.080)	5.08 (.200)	D7-200-701-010	D7-200-711-010	D7-200-721-010
	13.7 (.54)	1.80 (.071)	3.10 (.125)	D7-201-802-010	3.43 (.135)	6.35 (.250)	D7-201-701-010	D7-201-711-010	D7-201-721-010
2001	12.0 (.47)	Complete Assembly							
		0.05 (.020)	1.7 (.067)	~	2.5 (.098)	6.7 (.263)	D7-2001-010		