

CM Cam Locks

Cams & installation

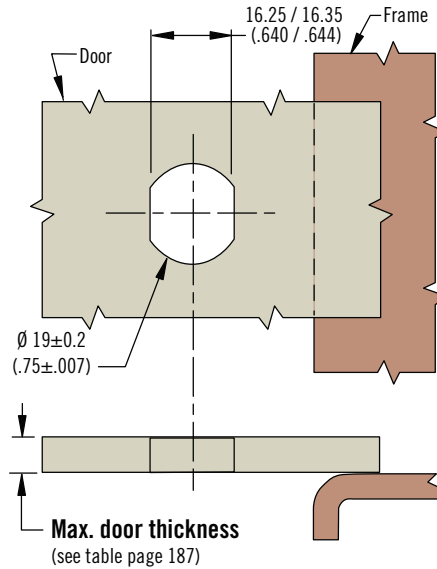
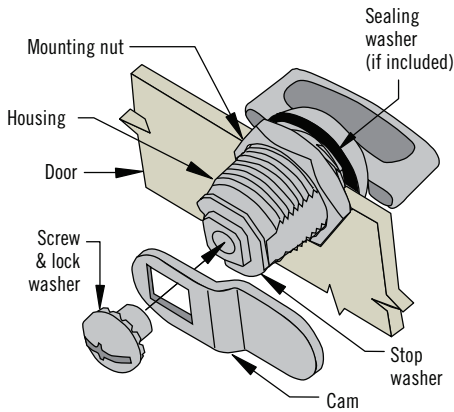

Installation Notes

1. Place sealing washer onto housing (if included) and put through the mounting hole (see panel preparation).
2. Install mounting nut and tighten to 5 N•m (44 in•lbf).
3. Install cam to assembly. Properly orientate for rotation and grip.
4. Install screw. Tighten to 4 N•m (35 in•lbf).

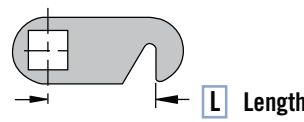
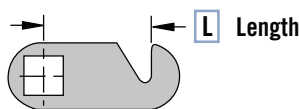
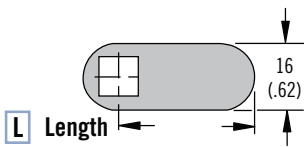
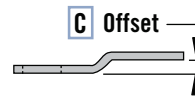
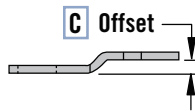
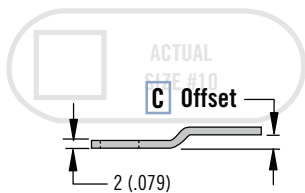

S C - No hook

S H - Hook type 1

S L - Hook type 2

Material and Finish

Cam: Steel plated

Part Number Selection

Order lock and cam separately
 Cam part number (no lock)
 For Lock selection see pages 188 - 190

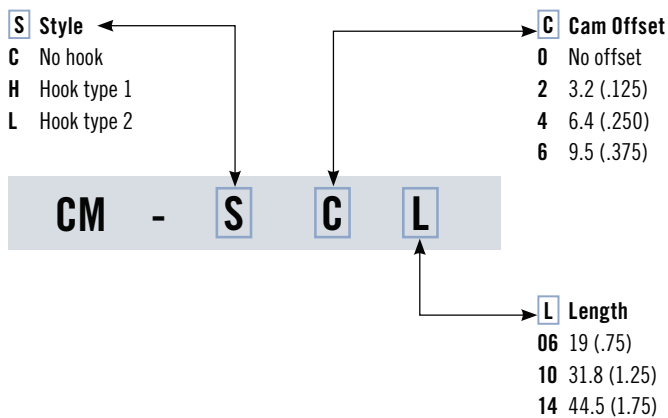

CM Cam Locks Selection



Cam Lock Selection Guide

1. Once you have determined the **CM Cam Lock** version that best meets your needs, calculate the **Cam Grip** for your application using the illustration below.

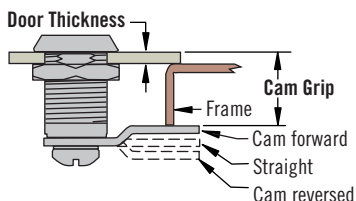

Notes: add 0.5 to your grip when using a sealed product.

2. In the **TAN** section below, locate the **Cam Grip** calculated for your application. If your grip falls between two values, use the higher value.

Notes: Certain grip values repeat in the table below. Use the value that results in the shortest housing possible based on the **Max. Door Thickness** allowed.

3. From this value, move right horizontally into the **GREY** section and verify your door thickness falls within the **Max. Door Thickness** listed. Once this is verified, the housing length is selected and is illustrated by the **Housing Length Number**.

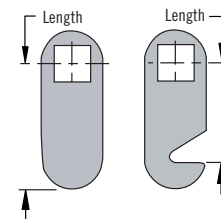

4. Returning to your original grip value in the **TAN** section, move down vertically into the **GREEN** section. The **GREEN** section illustrates the cams that are appropriate for your grip.

5. By determining the required cam orientation and length in the **BLUE** section, the appropriate **Cam Part Number** for your application is selected.

6. Proceed to the Cam Lock sections (CM-6, CM-3, CM-2, CM-5, and CM-1) to complete your **Part Number** selection.

Selection Guide

Cam Grips							Max. Door Thickness	Housing Length Number
20.7	17.5	14.3	11.1	8	4.8	1.6	2.4	7
25.4	22.2	19.1	15.9	12.7	9.5	6.4	7.1	1
31.8	28.6	25.4	22.2	19.1	15.9	12.7	13.5	2
38.1	34.9	31.8	28.6	25.4	22.2	19.1	19.8	6
44.5	41.3	38.1	34.9	31.8	28.6	25.4	26.2	3
50.8	47.6	44.5	41.3	38.1	34.9	31.8	32.5	4
57.2	54	50.8	47.6	44.5	41.3	38.1	38.9	5
Cam Part Number							Cam Length	Cam Orientation
Cam Reversed		Straight	Cam Forward					
CM-C606	CM-C406	CM-C206	CM-C006	CM-C206	CM-C406	CM-C606	19.1	No Hook
CM-C610	CM-C410	CM-C210	CM-C010	CM-C210	CM-C410	CM-C610	31.8	
CM-C614	CM-C414	CM-C214	CM-C014	CM-C214	CM-C414	CM-C614	44.5	
CM-L606	CM-L406	CM-L206	CM-H006	CM-H206	CM-H406	CM-H606	19.1	Left
CM-L610	CM-L410	CM-L210	CM-H010	CM-H210	CM-H410	CM-H610	31.8	
CM-L614	CM-L414	CM-L214	CM-H014	CM-H214	CM-H414	CM-H614	44.5	
CM-H606	CM-H406	CM-H206	CM-H006	CM-L206	CM-L406	CM-L606	19.1	Right
CM-H610	CM-H410	CM-H210	CM-H010	CM-L210	CM-L410	CM-L610	31.8	
CM-H614	CM-H414	CM-H214	CM-H014	CM-L214	CM-L414	CM-L614	44.5	

Also use the online configurator at www.southco.com