

# Southco® Push to Close Latches

## Sliding Flush Style

- Slide to open
- Mounts flush to the panel
- Operates from outside or inside the enclosure
- Optional keylock available
- Optional trimplate conceals mounting hardware

Push to Close Latches Visible

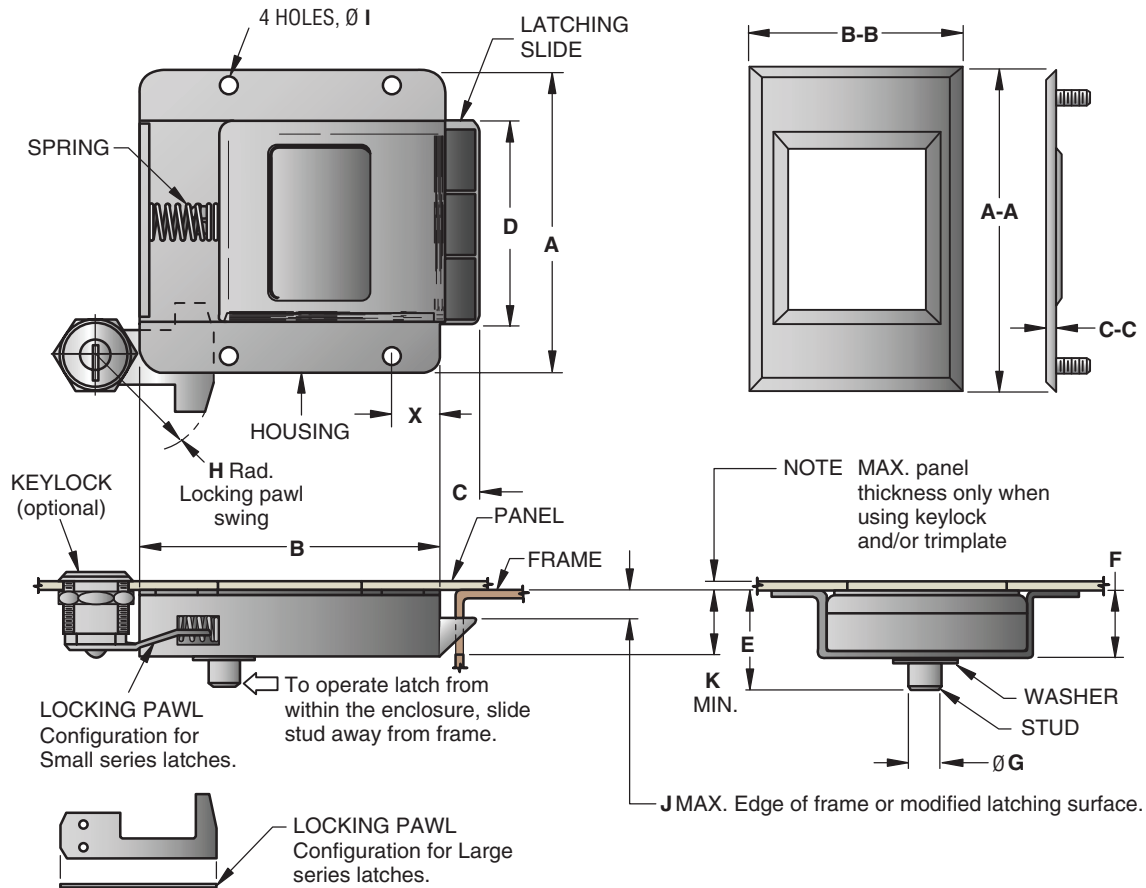

SIZE	DIMENSIONS									TRIMPLATE			WITH KEYLOCK		WITHOUT KEYLOCK	
	A	B	C	D	E	F	ØG	H	ØI	A-A	B-B	C-C	MAX. Panel Thickness	Part Numbers	MAX. Panel Thickness	Part Numbers
<b>With Mounting Trimplate</b>																
Small	89 (3.50)	88 (3.47)	10.5 (.41)	59 (2.31)	29.5 (1.16)	19 (.75)	9.5 (.38)	36.5 (1.44)	5.1 (.20)	95 (3.73)	63.5 (2.50)	2.5 (.10)	4 (.156)	B7-50-301-10 •	4 (.156)	B7-40-301-10 •
Large	118 (4.63)	117 (4.59)	14 (.55)	79 (3.13)	38.5 (1.51)	25 (.98)	12.7 (.50)	46 (1.81)	6.4 (.25)	126 (4.99)	85 (3.37)	3 (.12)	4.8 (.188)	B7-50-501-10 •	4.8 (.188)	B7-40-501-10 •
<b>Without Mounting Trimplate</b>																
Small	89 (3.50)	88 (3.47)	10.5 (.41)	59 (2.31)	29.5 (1.16)	19 (.75)	9.5 (.38)	36.5 (1.44)	5.1 (.20)	—	—	—	5.5 (.219)	B7-20-301-10 •	—	B7-10-301-10 •
Large	118 (4.63)	117 (4.59)	14 (.55)	79 (3.13)	38.5 (1.51)	25 (.98)	12.7 (.50)	46 (1.81)	6.4 (.25)	—	—	—	6.4 (.25)	B7-20-501-10 •	—	B7-10-501-10 •

SIZE	DIMENSIONS															FOR MOUNTING ASSEMBLIES WITHOUT TRIMPLATES				
	J MAX.	K MIN.	M ±0.3 (±.015)	N ±0.3 (±.015)	O ±0.2 (±.010)	P ±0.2 (±.010)	Q ±0.2 (±.010)	R ±0.2 (±.010)	S		T ±0.2 (±.010)	U ±0.2 (±.010)	Vr MAX.	ØW +0.1 -0.0 (+.003 -0.000)	X ±0.2 (±.010)	Y MIN.	English		Metric	
									MIN.	MAX.							Screw	Rivet	Screw	Rivet
Small	6.4 (.250)	16.5 (.65)	50 (2.00)	44 (1.72)	2 (.08)	79.5 (3.125)	47.5 (1.875)	14.3 (.56)	20.5 (.80)	23.5 (.92)	38 (1.50)	15 (.56)	6.5 (.25)	5.5 (.219)	15.5 (.61)	62 (2.44)	No.10	Ø 3/16	5 mm	Ø 5 mm
Large	7.9 (.313)	21.5 (.85)	68 (2.69)	58 (2.28)	3 (.11)	105 (4.125)	63.5 (2.500)	18.5 (.72)	24.5 (.97)	30 (1.22)	51 (2.00)	9 (.34)	8 (.32)	7 (.281)	20 (.80)	83 (3.25)	1/4	Ø 1/4	6 mm	Ø 6 mm

## Installation

1. Prepare door panel, and prepare frame if necessary.

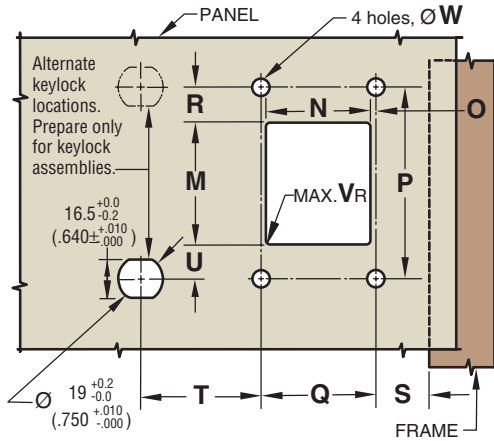

2. Pass integral studs of Trimplate through holes. Place latch over studs and secure with nut/lockwasher assemblies.

Latch used without Trimplate may be installed by welding or using rivets or screws.

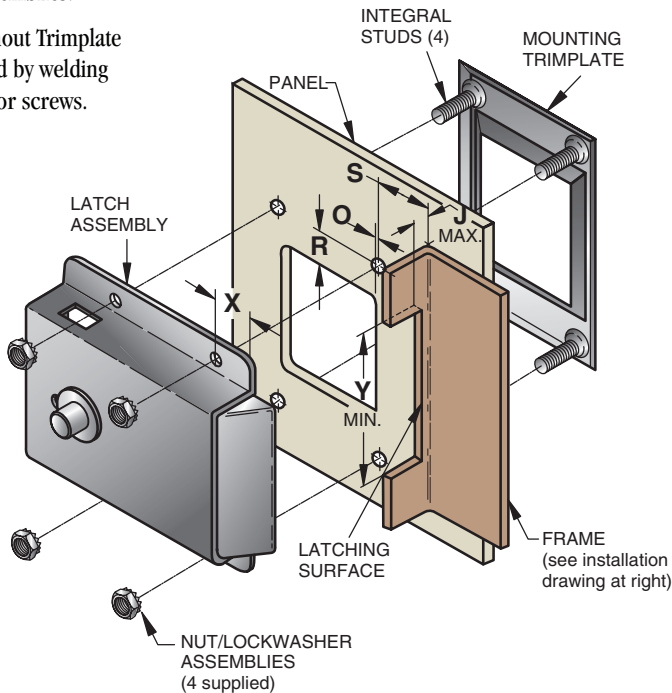

### For Keylock:

Prepare hole in door.

When installed, be sure pawl cleanly enters opening in side of housing.

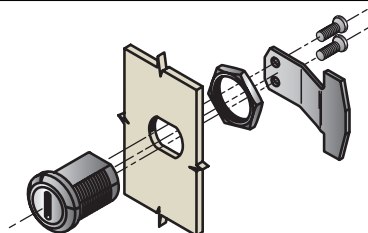

## Material and Finish

HOUSING: 1010 Steel, black powder coated.

SLIDE: Nylon, black.

WASHER: Acetal, black

STUD: Low carbon steel, zinc immersion coating.

TRIMPLATE: 1010 Steel, black powder coated.

NUT/LOCKWASHER ASSEMBLIES: Steel, zinc plated.

LOCK: Die-cast zinc, black powder coated. LOCKING PAWL: 1010 Steel, zinc plate chromate plus sealer.

MOUNTING SCREWS (locking pawl): Steel, zinc plated.

MOUNTING HEX NUT (for lock): Die-cast zinc, chemical protective coating.

KEY (2 Supplied): Brass, nickel plated.

Locks are keyed alike. Different key codes are available. Contact Southco for details.

## Product Strength Guidelines

(To assist in your product selection; samples are available for your evaluation.)

### Small

Maximum static load: 360 N (80 lbs.)

Average ultimate load: 640 N (140 lbs.)

### Large

Maximum static load: 530 N (120 lbs.)

Average ultimate load: 1200 N (260 lbs.)

**Flammability Rating:** UL 94 - HB

**Operating Temperature Range:**

-18°C (0°F) to 65°C (150°F)

millimeter (inch)  
millimeter  
(inch)

Dimensions without tolerances are for reference only.