

AC-40 Multi Point Actuator Push-Button Handle

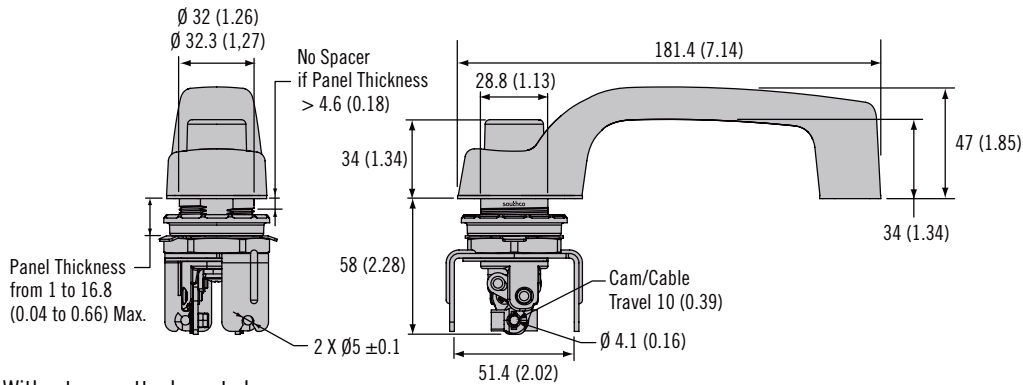

With cam attachment shown



Without cam attachment shown

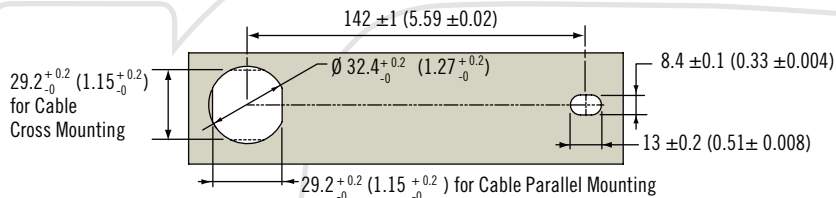
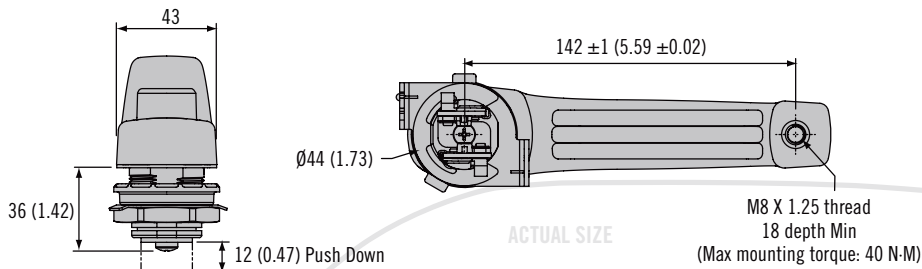

- Single or multi-point actuation capability
- Accommodates wide panel thickness
- Multiple key code options
- Easy Grip

Material and Finish

Button: Nylon
Housing: Zinc Die Cast or Stainless Steel
Lock Plug: Zinc Die Cast
Cam, Washer, Rivet:
Stainless Steel, Passivated

Part Number Selection

E End Style

- 1 With Cam attached
- 3 Without Cam attached

H Handle Material

- 1 Black GF nylon with zinc housing insert
- 2 Black GF nylon with stainless steel housing insert

B Button Material

- 1 Nylon with black molding

KC Key Codes
(Omit for locking options 1,2,4 and 5)
KD10 Keyed differently (10 codes)
MK10 Master keyed, keyed differently

M Mounting Method

- 1 Cable parallel (or no cable), with spacer mounting (must have if glass panel)
- 2 Cable parallel (or no cable), without spacer mounting
- 3 Cable cross with spacer mounting (must have if glass panel)
- 4 Cable cross without spacer mounting

L Locking Option

- 1 Reversible key (No keys - R001)
- 2 Reversible key (2 keys included - R001)
- 3 Reversible key (Multiple key codes - 2 keys included)
- 4 Standard key (No keys - CH751)
- 5 Standard key (2 keys included - CH751)
- 6 Standard key (Multiple key codes - 2 keys included)

AC - 40 - E L M - H B - KC

Dimensions in millimeters (inch) unless otherwise stated



Global Corporate Headquarters and Americas Customer Service & Technical Support Center
Tel: (1) 610-459-4000 · Fax: (1) 610-459-4012 · www.southco.com · info@southco.com



Other options available. For complete details on variety, part numbers, installation and specification, go to

www.southco.com/AC

© Southco AC-30/40 752NA 05-11