



AC-30 Multi Point Actuator Push-Button

- Single or multi-point actuation capability
- Accommodates wide panel thickness
- Multiple key code options
- Single hole install

Material and Finish

Button: Nylon
 Housing: Zinc or Stainless Steel
 Lock Plug: Zinc
 Cam, Washer, Rivet:
 Stainless Steel, Passivated

With cam attachment shown

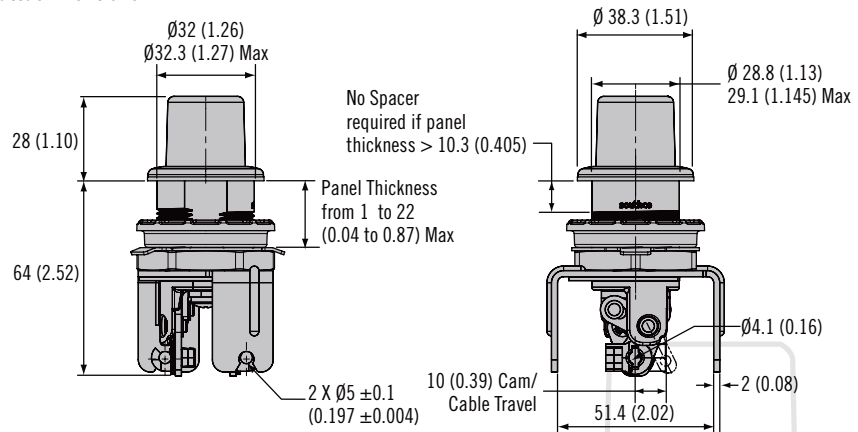

Without cam attachment shown

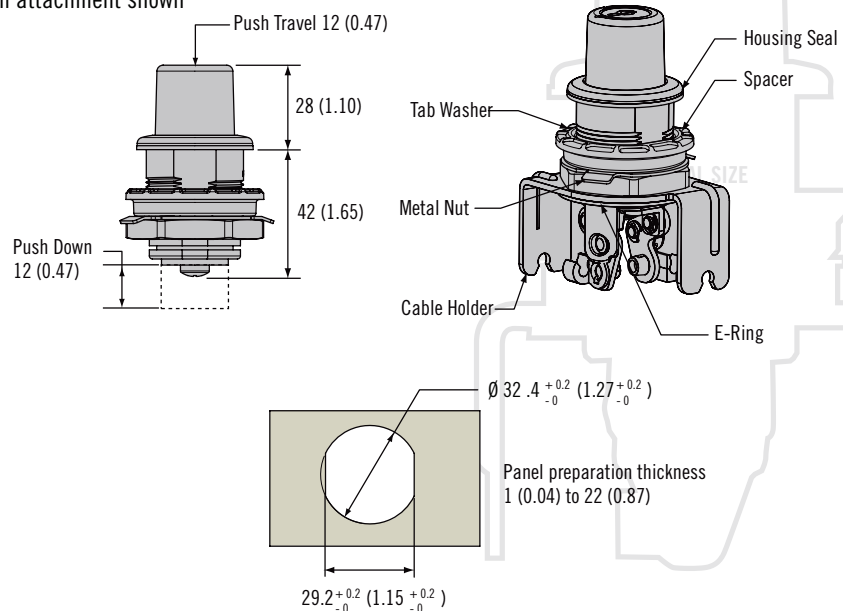

Part Number Selection

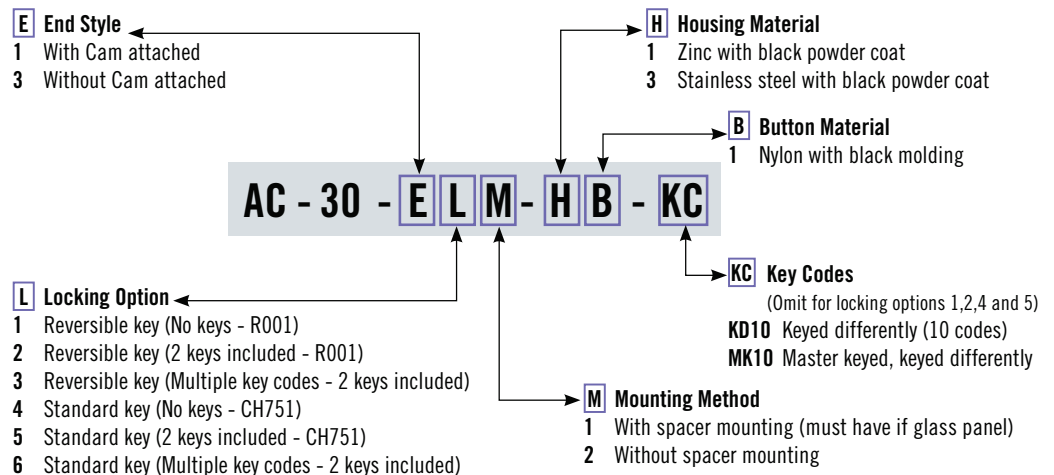

Other options available. For complete details on variety, part numbers, installation and specification, go to

INFO CLIC www.southco.com/AC

Dimensions in millimeters (inch) unless otherwise stated

southco
 CONNECT · CREATE · INNOVATE