

# Southco® Multi-point Latching Systems

## Rod-roller Compression System

- For 2- or 3-point latching
- Provides up to 3 mm (.12 in) of consistent compression
- Accommodates a wide range of frame and gasket variations
- Operates with multiple Southco® latch families

### Side View

Latched (Without Keeper)

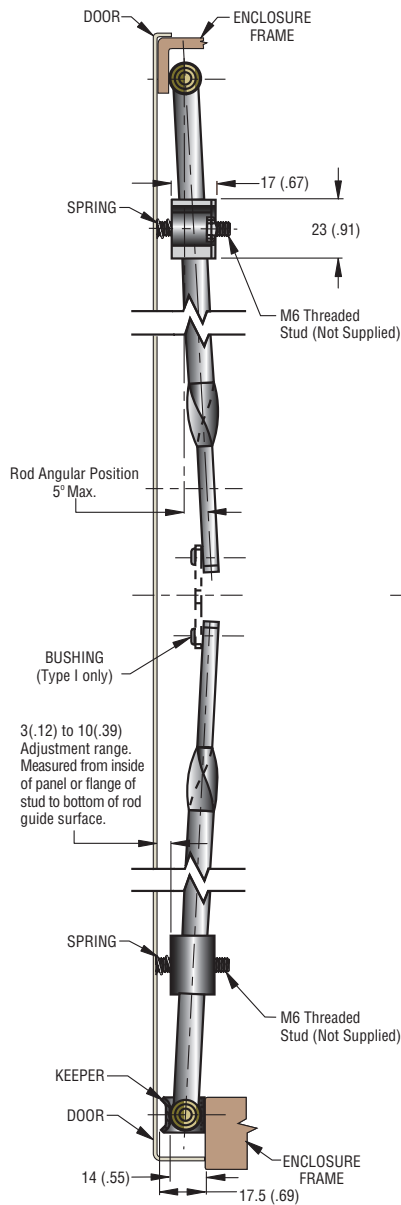

Latched (With Keeper)

### Viewed From Inside Enclosure

Latched (Without Keeper)

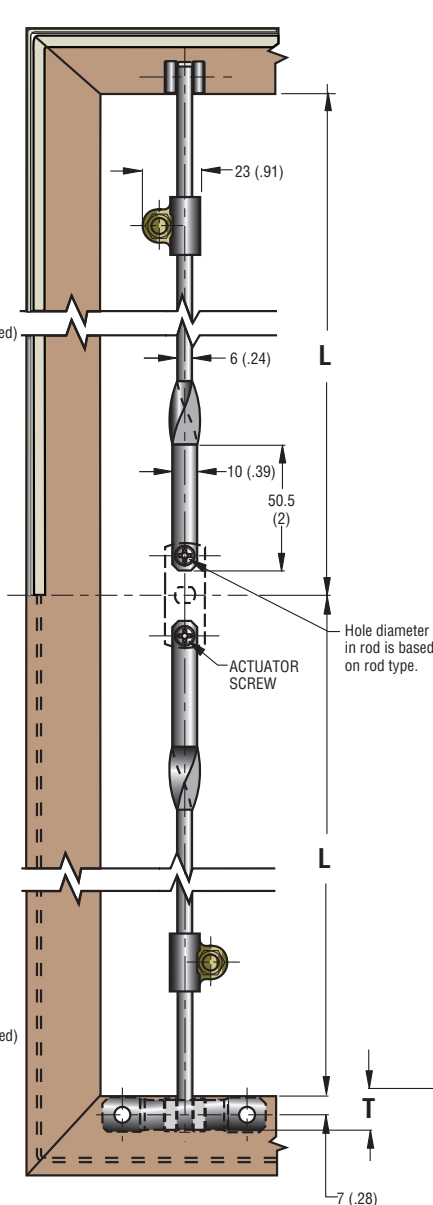

Latched (With Keeper)

Unlatched (Without Keeper)

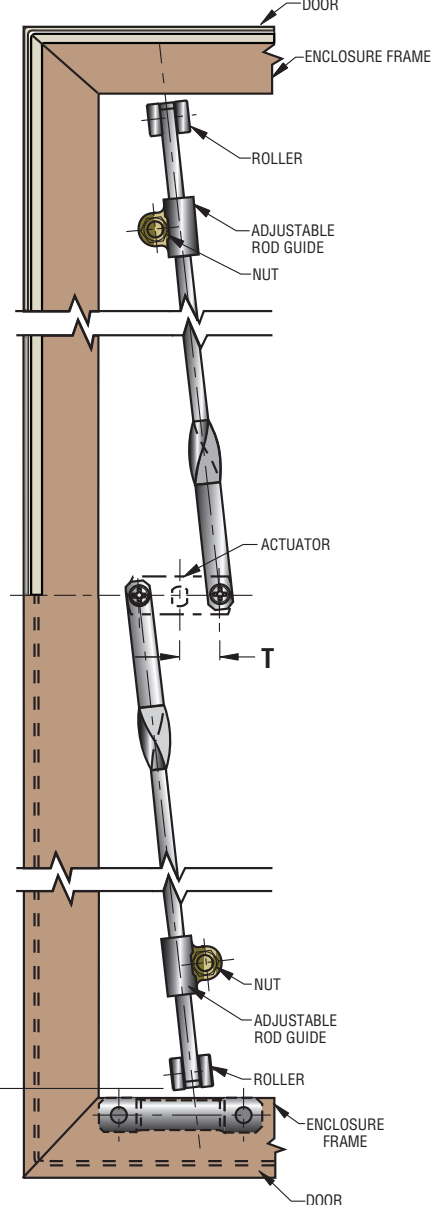

Unlatched (With Keeper)

### Keeper

PART NUMBER

A8-60 •

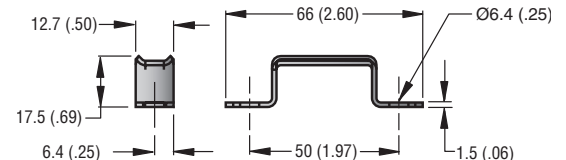

Multi-point Latching System

## To order rod assemblies and hardware

- Determine Southco latch family from table below. **Order one.**
- Select hardware package from table, **order one.**
- The keeper, part number A8-60, is **optional**. Order separately, **one or two.**
- Determine rod length (XXXX), in millimeters from 250 MIN. to 1500 MAX. using the following formula:  

$$L - T + 7 \text{ mm} = \text{XXXX}$$

L = latch pivot centerline to frame edge dimension  
 T = latch actuator throw (see table below)
- The rod assembly length determined in step 4 should be rounded down to the next smallest whole millimeter. Example: If you determine your rod length to be 624.6 mm, then the rod length (XXXX) is 0624. For rod assemblies under 250 mm or over 1500 mm call Southco for information.
- Order each rod separately. Some applications will require different rod lengths when the operating latch is mounted off-center.

7 mm = roller engagement constant  
 XXXX = rod length ordered by customer

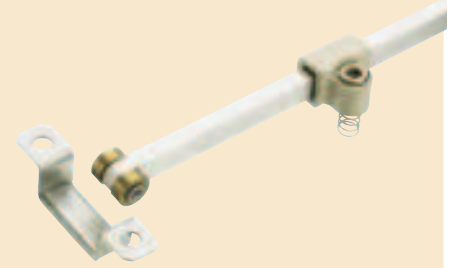

OPERATING LATCH FAMILIES	SIZE/STYLE	HARDWARE PART NUMBER*	ROD TYPE	T (IN MILLIMETERS)
No. E5 Quad Panel Latches	ALL	A8-24	I	23
No. 24 Flush (Cup) Latches	2 or 3 Point Latching Only (non-locking)	A8-25	I	17.5
No. 62 Lift-and-Turn Latches	Medium (Flush)	A8-22	I	16.1
	Medium			
	Large	A8-20	I	22.2
	Large (Flush)**	A8-25	I	31.8
	Heavy Duty**			
No. 68 Bail and T-handle Latches	Bail Handle	A8-20	I	22.2
	Large T-handle			
	Medium T-handle	A8-25	I	17.5
No. 92 L and T-handle	ALL	A8-21	II	19
No. E3 Vise-action Compression Latches	International Hex Driver and T-Handle	A8-25	I	27.4
No. 01 Flush Recess Latch	Mid-size	A8-31	III	19

\* Hardware package includes the following: rod guide support spring (2 each), M6 nut (2 each), M4x8 screws (2 each), plus additional hardware to install the rod roller system with the selected latch.  
 \*\* Order actuator separately - part number 62-19-501-15.

### Rod Assembly Part Number

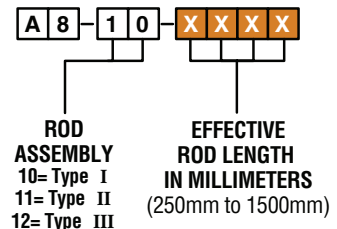

**EXAMPLE:**  
 If your effective rod length is 750 mm, substitute 0750 for the XXXX portion of the basic part number.  
**Example: A8-10-0750 for Type I, A8-11-0750 for Rod Type II or A8-12-0750 for Type III.**

### Material and Finish

RODS: Aluminum, natural.  
 ROLLERS: Brass, natural.  
 RIVETS: 7050 Aluminum, clear anodized.  
 ROD GUIDE: Nylon, natural.  
 SPRING: 302 Stainless steel, passivated.  
 NUT: Low carbon steel, zinc plated plus yellow chromate dip.  
 ACTUATOR SCREW: Steel, zinc alloy plated, bright chromate plus sealer.  
 THREADED BUSHING: Brass, natural.  
 KEEPER: 1010 Steel, zinc plate, chromate plus sealer.

### Product Strength Guidelines (Per Roller)

(To assist in your product selection; samples are available for your evaluation.)  
 Maximum static load: 225 N (50 lb.)  
 Average Ultimate Force: 1200 N (270 lb.)  
**Flammability Rating:** UL94-V0  
**Operating temperature range:**  
 -0°C (-18°F) to 100°C (210°F)

millimeter (inch)  
 millimeter  
 (inch)

Dimensions without tolerances are for reference only.

Multi-point Latching System

### Example: Ordering Information (Rod Type I)

#### Centered Operating Latch

Once you have determined your rod length, the latch location is **centered** on a 2000 mm cabinet which measures from inside one edge to inside the opposite edge of the frame. The operating latch is a No. 68 large T-handle. The components ordered are:

- Quantity 1, selected latch
- Quantity 1, installation hardware package, part number A8-20.
- Quantity 2, keepers (optional), part number A8-60.
- Quantity 2, rod assemblies A8-10-0984.

Ex.: 1000 mm - 22.2 + 7 = 984.8  
 XXXX = 0984.

#### Off-centered Operating Latch

To order unequal length rods for actuator latches located 50 mm **off-center** on a 2000 mm cabinet. The components ordered are as follows using a No. 68 Large T-Handle Latch:

- Quantity 1, selected latch
- Quantity 1, installation hardware package, part number A8-20.
- Quantity 2 keepers (optional), part number A8-60.
- Quantity 1 rod assembly of each length for each side of actuator latch: A8-10-1034 and A8-10-0934.

Ex.: 1050 mm - 22.2 + 7 = 1034.8,  
 XXXX = 1034;  
 950 mm - 22.2 + 7 mm = 934.8,  
 XXXX = 0934.

### Rod Type I

To attach rod to latch actuators having  $\varnothing 6.5 (.25)$  holes.

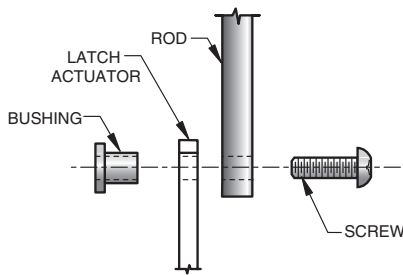

\*Important: Apply 1.7 N·m (15 lb·in) torque to secure bushing/screw assembly.

### Rod Type II

To attach rod to latch actuators having  $\varnothing 4.9 (.19)$  holes.

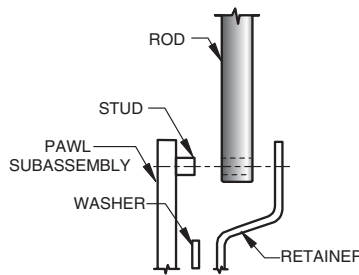

### Rod Type III

To attach rod to latch actuators having  $\varnothing 4.9 (.19)$  holes.

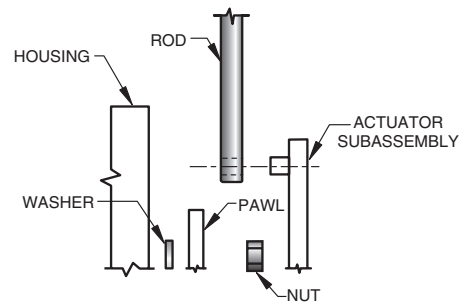

## Assembly Instructions

### (Rod Type I):

1. Attach each rod assembly to actuator using one M4 x 8 machine screw and threaded bushing. The rod end may be fastened to the top or bottom side of the actuator.
2. Place spring and rod guide on an M6 threaded stud. Depress rod guide, thread M6 nut onto stud, then adjust position of M6 nut for up to 3 mm (.12) roller engagement. The rod angular position must not exceed 5 degrees (max.), measured from the rod roller end (see page 2).

**Note:** The rod guide is designed with an integral nut locking feature to prevent nut from rotating. Failing to depress the rod guide before adjusting may strip the rod guide detent.

3. The keeper (when used) is fastened to the front side of the enclosure frame, with the edge parallel to the inside edge of the enclosure frame, using M6 hardware (not supplied). Otherwise the rollers can engage the back edge of the enclosure frame which must have a 3 mm (.12) minimum radius to help assure smooth roller engagement.
4. Actuator may be placed on either side of pawl depending on your grip requirements.

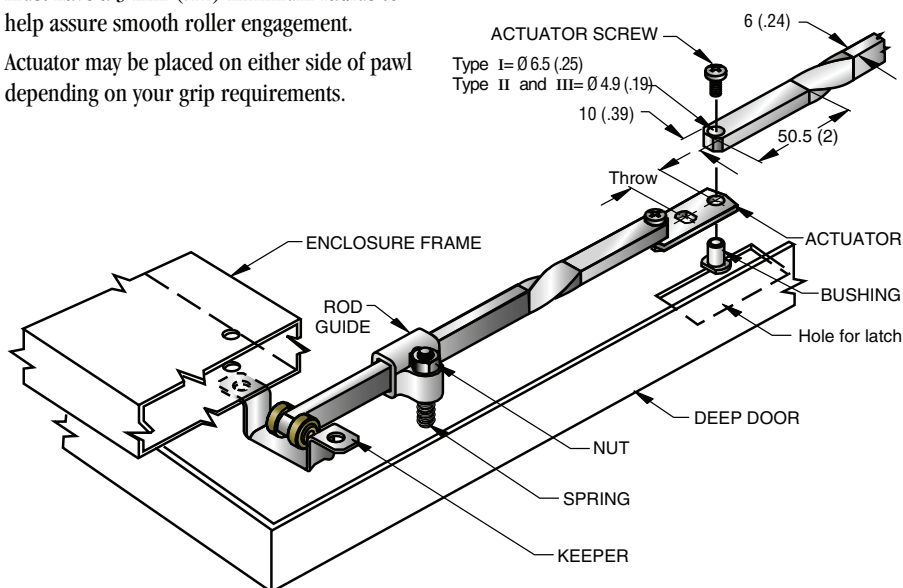

## Assembly Instructions

### (Rod Type II):

1. Place each rod assembly onto the stud of the pawl subassembly. Then place the M10 flat washer (from the rod assembly hardware package), retainer, lockwasher and M10 nut onto the latch shaft. The rod angular position must not exceed 5 degrees, maximum measured from roller end (see page 160).
2. Continue by referring to steps 2 - 4 of Rod Type I assembly instructions.

## Assembly Instructions

### (Rod Type III):

1. Place each rod assembly onto the stud of the actuator subassembly after the latch pawl has been installed. Then place the lockwasher and hex nut onto the latch shaft.
2. Continue by referring to steps 2 - 4 of Rod Type I assembly instructions.

## DOOR/FRAME PREPARATION (Viewed From Inside Enclosure)

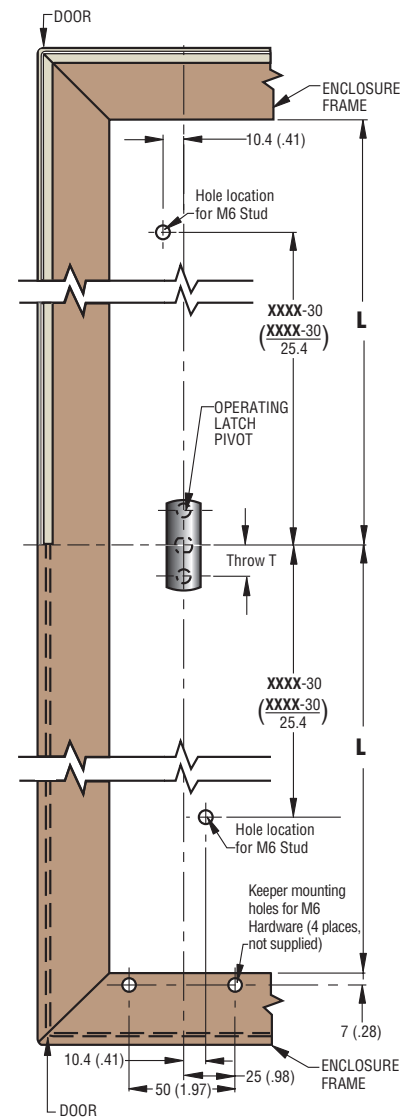

millimeter (inch)  
millimeter (inch)

Dimensions without tolerances are for reference only.