

A7 Compression Latch

Lever latch · Over-center action

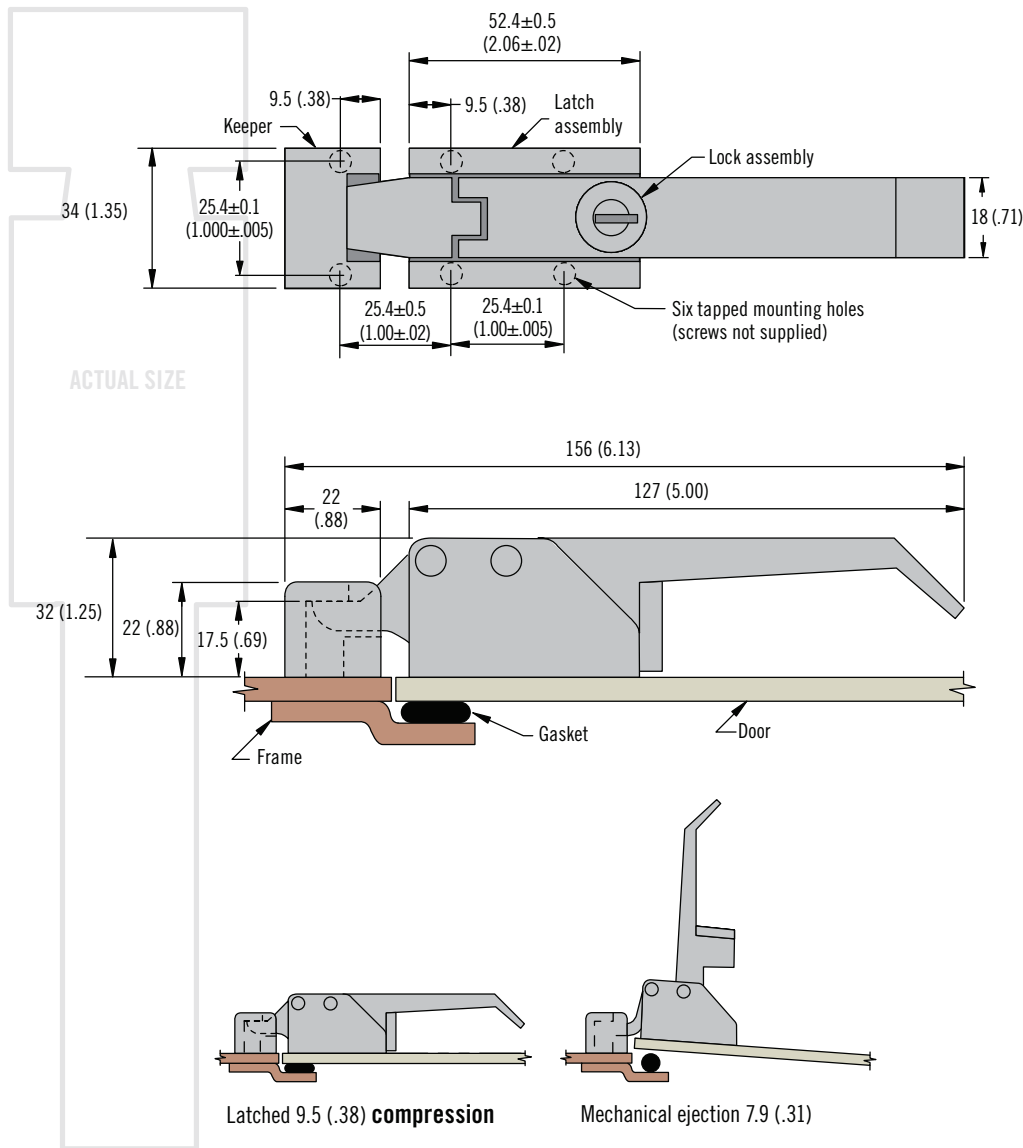

- Intuitive operation
- Built in leverage helps open stuck doors
- Consistent gasket compression

Material and Finish

Zinc alloy, powder coated or chrome plated and steel, zinc plated

Performance Details

Max. static load: 2200 N (500 lbf)

Keys

See page 58

Part Number Selection

L Lock Style

- 1 Non-locking
- 2 Key-locking keyed alike CH751 (two flat keys supplied)

F Finish

- 20 Black powder coated
- 30 Chrome plated
- 75 Satin silver coated

A7 - 1 0 - 3 T L - F

T Tapped mounting

- 0 Tapped mounting hole 10-32UNC x .38 deep
- 5 Tapped mounting hole M5 x 0.8 x 9.5 deep



Dimensions in millimeters (inch) unless otherwise stated



www.southco.com/A7