

Southco® Push to Close Latches

Quarter-turn to Open

- Tool-operated style offers added security
- Hand-operated style provides quick access
- Each style is available in two sizes

Tool Actuated Style

Hex tool actuated style is dimensionally identical to knob style except as shown.

Knob Actuated Style

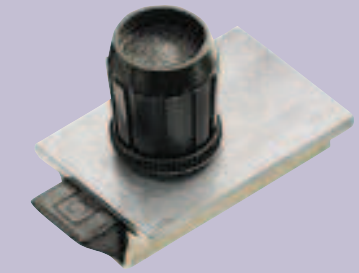
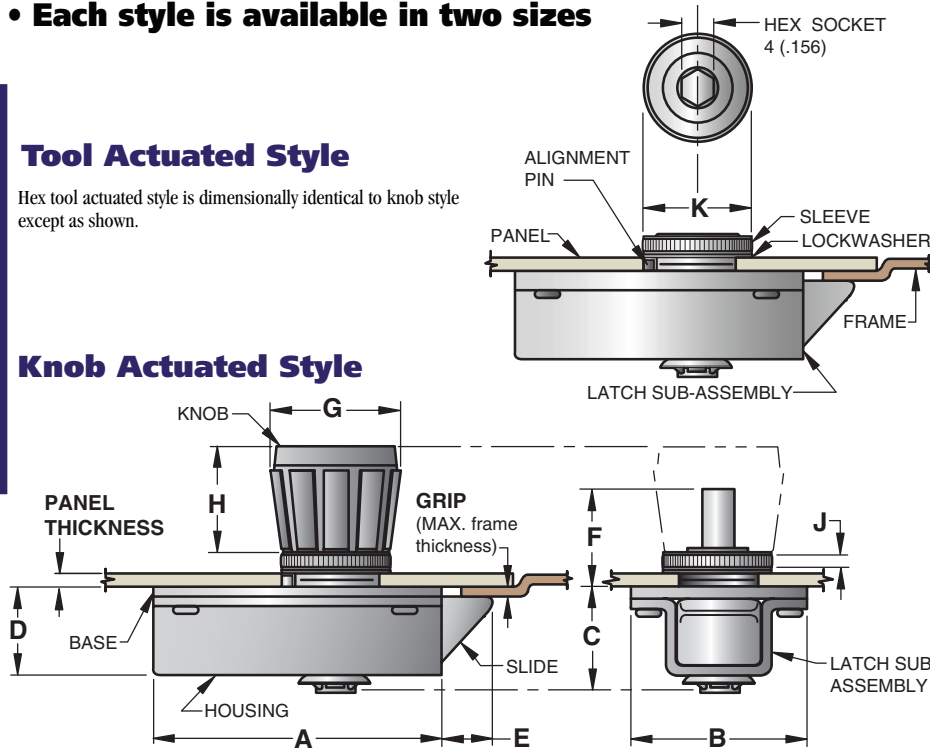

Material and Finish

HOUSING: 1010 Steel, zinc plated plus sealer.
 SLIDE and PINION: Die-cast zinc, black organic coating.
 BASE: Die-cast zinc with chemical protective coating.
 SPRING: 302 Stainless steel, passivated.
 RETAINER: Spring steel, zinc plated plus chromate dip.
 LOCKWASHER: Spring steel, zinc immersion coating.
 SLEEVE: Low carbon steel, black organic coating.
 KNOB: Nylon, black.

SERIES	PANEL THICKNESS		GRIP (Max. frame thickness)	DIMENSIONS										PART NUMBERS	
	MIN.	MAX.		A	B	C	D	E	F	G	H	J	K	Knob Actuated Style	Hex Tool Actuated Style
40	1 (.036)	3.2 (.125)	1.6 (.063)	35 (1.38)	23 (.91)	13.5 (.53)	11 (.43)	6.5 (.25)	14 (.55)	15 (.59)	15 (.59)	2.5 (.09)	14.5 (.56)	A6-40-112-10 •	A6-40-312-10
			3.2 (.125)			15 (.59)	12.5 (.49)							A6-40-114-10 •	A6-40-314-10 •
60	1 (.036)	4.8 (.188)	4.8 (.188)	52.5 (2.06)	32 (1.25)	21 (.83)	18.5 (.73)	9.5 (.38)	19 (.74)	24.5 (.97)	19 (.75)	3 (.13)	19 (.75)	A6-60-116-10 •	A6-60-316-10 •

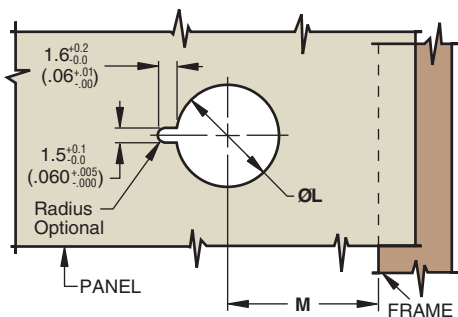

SERIES	Ø L	M	WRENCH PART NO.
40	11.2±0.1 (.437±.008)	16±1.5 (.63±.06)	A6-0-15640-11 •
60	16±0.1 (.625±.008)	24±2.2 (.94±.09)	A6-0-15641-11 •

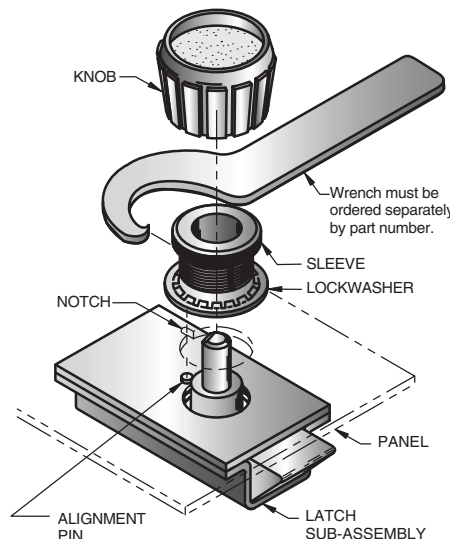

Installation

Prepare hole in panel as shown.

Pass shaft of latch through hole from back side of panel, fit alignment pin into notch, apply lockwasher and thread sleeve over shaft from front side of panel. **Note:** Alignment pin is for proper orientation and alignment of latch during installation only. When tightening sleeve, be sure to hold latch firmly in position.

This completes installation of tool actuated style. For knob style, orient shaped hole in knob with flat on shaft and press knob fully onto shaft.

millimeter (inch)
 millimeter (inch)

Dimensions without tolerances are for reference only.

Push to Close Latches Visible