

96 Hinge

Lift-off · Offset · Zinc

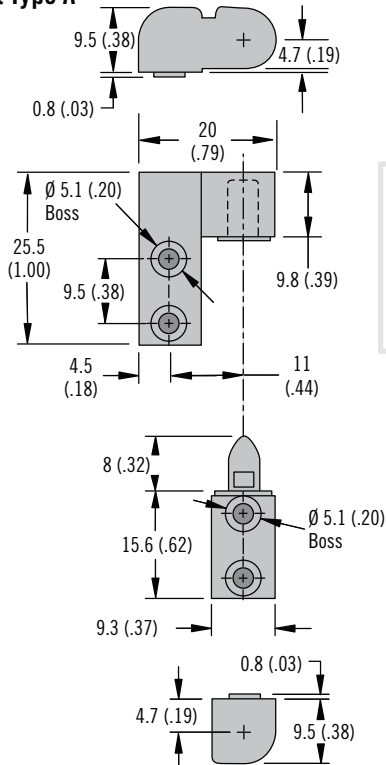

Offset Type A



Offset Type B

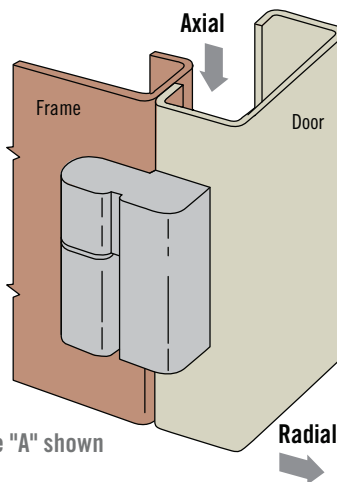
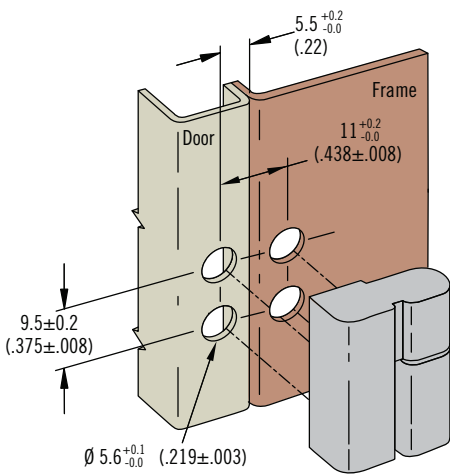
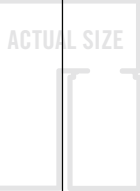
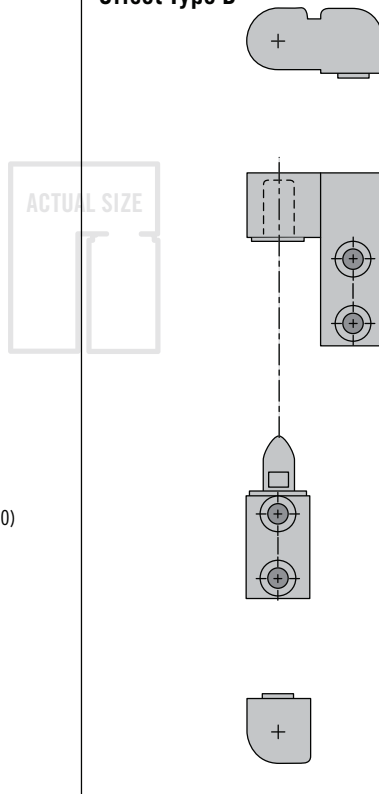

Type "A" shown

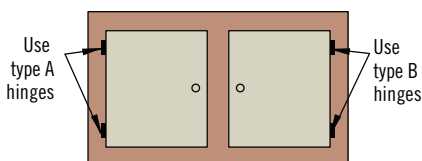

- Allows for quick, easy door removal
- Door can also be permanently installed

Material and Finish

Zinc alloy, black powder coated

Performance Details

	Radial Load	Axial Load
Max. static load	1100 N (250 lbf)	1250 N (280 lbf)
Average ultimate load	3300 N (750 lbf)	2600 N (580 lbf)

Installation Notes

Screws not supplied.

Recommended tightening torque for mounting screws:

1.1 N·m (10 in·lbf)

Calculate screw length using the following formula:

Door / frame thickness + 5 (.20)

Tapped Hole	Part Number	
	Type A	Type B
Imperial 6-32	96-111	96-112
Metric M4 x 0.7	96-141	96-142

Part Number

See table