

# Southco® Pawl/Cam Action Latches

## Bail-handle Series, Large Size

- Restricted 90° rotation
- Mounts from inside the panel so no mounting hardware is visible
- Detents hold the handle in the open and stored positions
- Clockwise or counterclockwise operation



### Material and Finish

ESCUTCHEON and STOP WASHER: Die-cast zinc, chemical protective film or chrome plated (see table).

BAIL HANDLE: 1008 Steel, zinc plate bright chromate or chrome plated (see table).

SHAFT: Low carbon steel, zinc plate bright chromate or chrome plated (see table).

PAWL, ACTUATOR, BASE PLATE and TAB WASHER: 1010 Steel, zinc plate, chromate plus sealer.

JAM NUTS and MOUNTING SCREWS: Steel, zinc plate, chromate plus sealer.

WASHER: Spring steel, zinc plate, chromate plus sealer.

### Product Strength Guidelines

(To assist in your product selection; samples are available for your evaluation.)

Average ultimate load: 1300 N (300 lbs.)

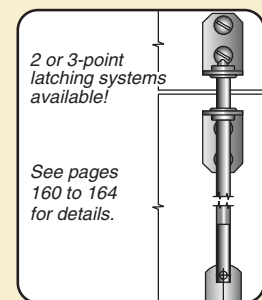

millimeter (inch)  
millimeter  
(inch)

Dimensions without tolerances are for reference only.

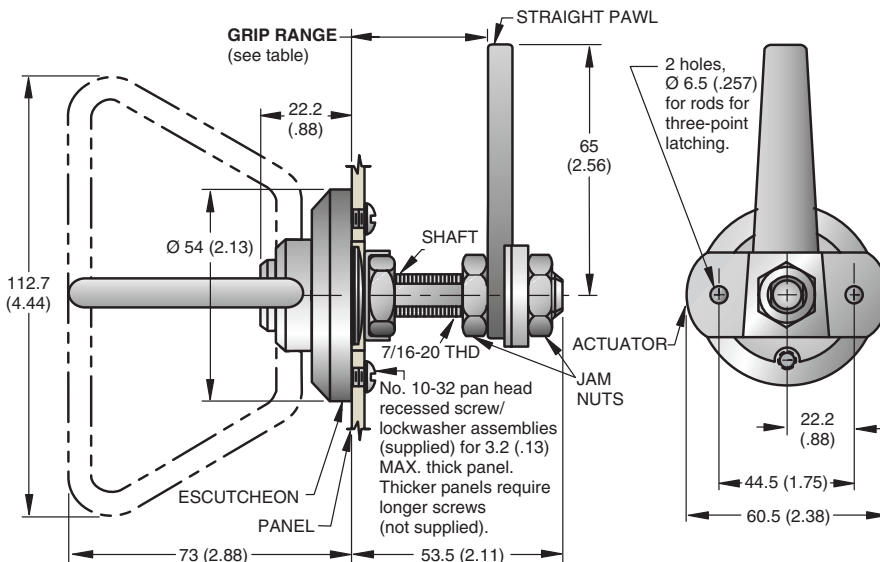

GRIP RANGE		PART NUMBERS	
MIN.	MAX.	Handle Assembly finish	
		Zinc Plate Bright Chromate	Chrome Plated
16 (.63)	36.5 (1.44)	68-80-302-10 •	68-80-302-20 •

Latch is shipped unassembled, one unit per package.

## Installation and Operation

1. Prepare panel as shown.

**Type "B" Operation**  
Turn bail handle counterclockwise to latch.

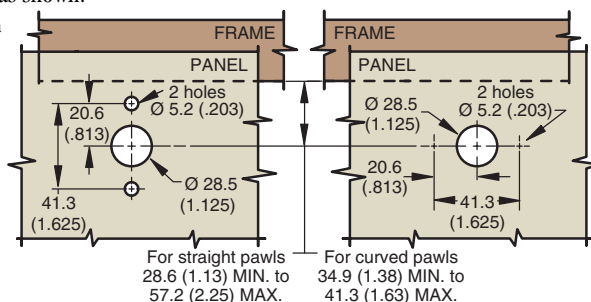

**Type "A" Operation**  
Turn bail handle clockwise to latch.

2. Assemble as shown.

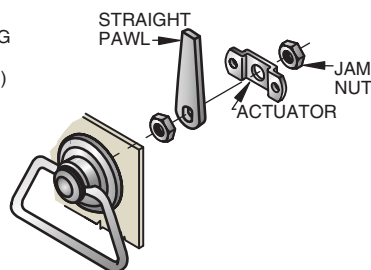
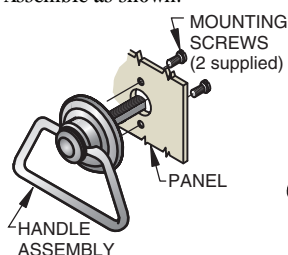

3. Adjust pawl to GRIP measurement. Use two wrenches to tighten.

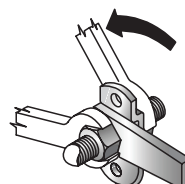

Note: the handle is always perpendicular to the pawl.