

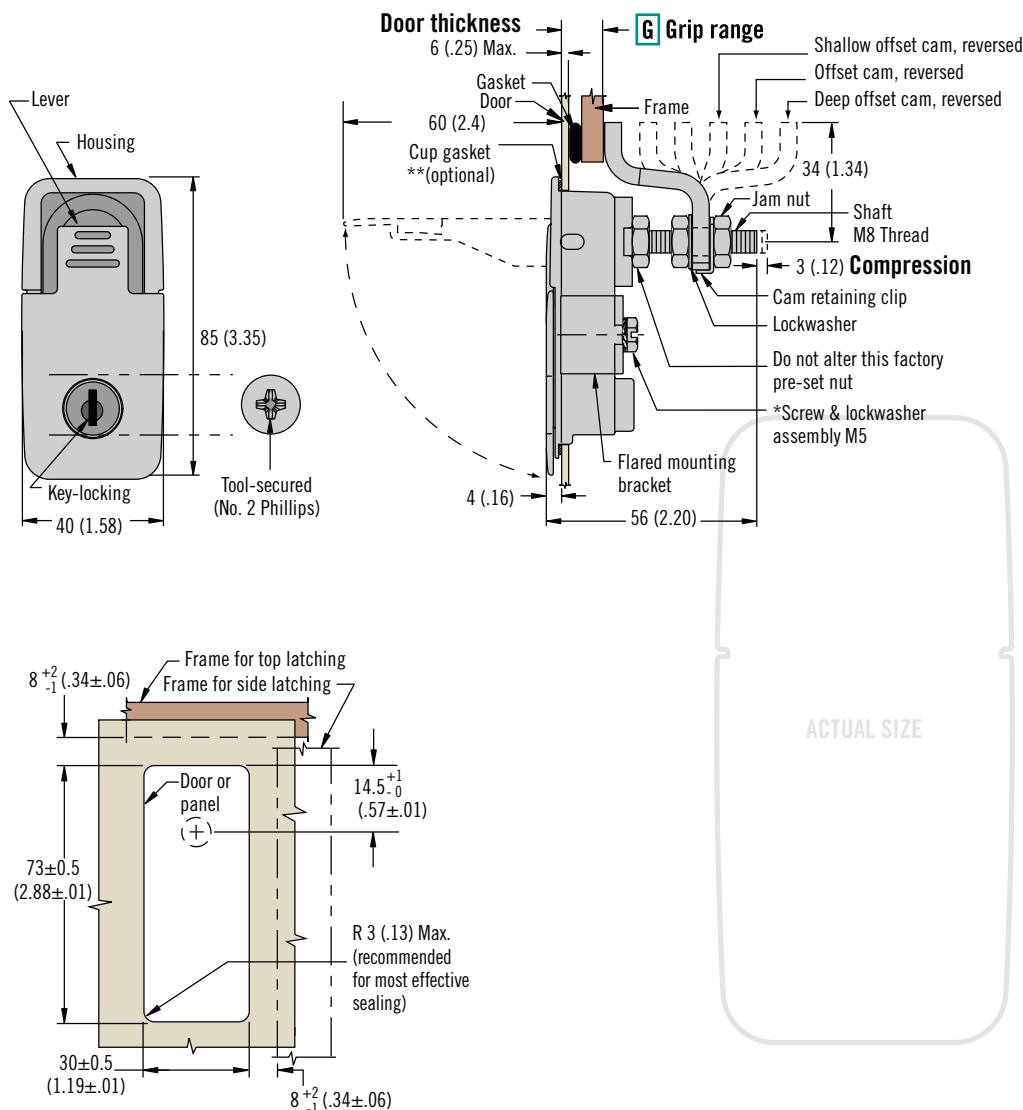

# 62 Compression Latch

Medium · Lift & turn series · Flush style · Adjustable grip



- Low profile when latched
- Easy grip adjustment
- Intuitive operation

### Material and Finish

Zinc alloy, powder coated or chrome plated and steel, zinc plated

### Performance Details

Max. static load: 440 N (100 lbf)

### Sealing Notes

Environmental sealing is achieved by using a cup gasket and sealing the mounting screw threads.

### Installation Notes

\*Screw and lockwasher assembly M5 x 16. For door thickness greater than 6 (.25) calculate screw length using the following formula:  
Door thickness + 10 (.39)

\*\*Add 0.4 (.02) to door thickness when using cup gasket

### Accessories

Cup gasket:  
Part number: 62-973-431

### Keys

See page 58

### Notes

For lock core selection and a complete overview of the *SOUTHCO*® Key-Choice System see pages 182 - 183

### Part Number Selection

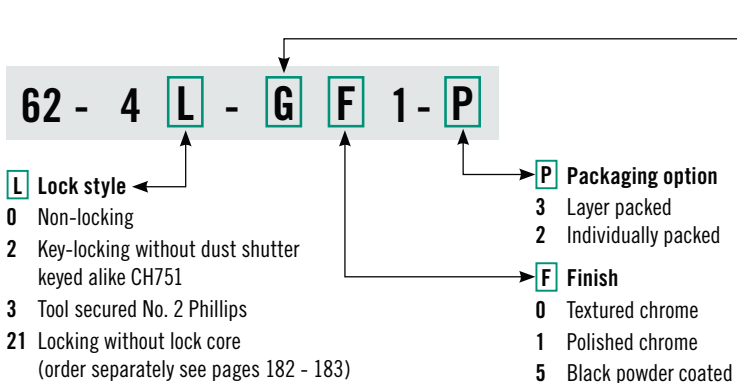

Grip	Min.	Max.	Cam Type
1	6 (.23)	16 (.63)	Deep offset cam, forward
	56 (2.20)	66 (2.59)	Deep offset cam, reversed
2	16 (.63)	26 (1.02)	Offset cam forward
	46 (1.81)	56 (2.20)	Offset cam reverse
3	26 (1.02)	36 (1.41)	Shallow offset cam, forward
	36 (1.41)	46 (1.81)	Shallow offset cam, reversed