



# 62 Compression Latch

Small · Lift & turn series · Handle style · Adjustable grip

- Easy grip adjustment
- Intuitive operation

### Material and Finish

Zinc alloy, powder coated or chrome plated and steel, zinc plated

### Performance Details

Max. static load: 550 N (125 lbf)

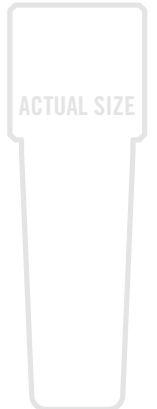
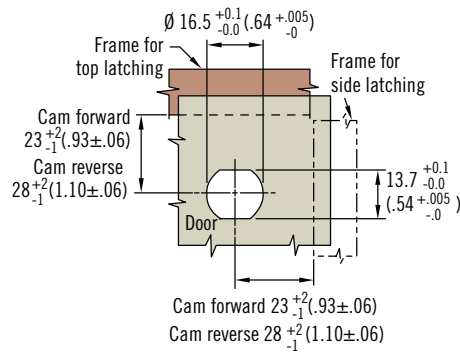
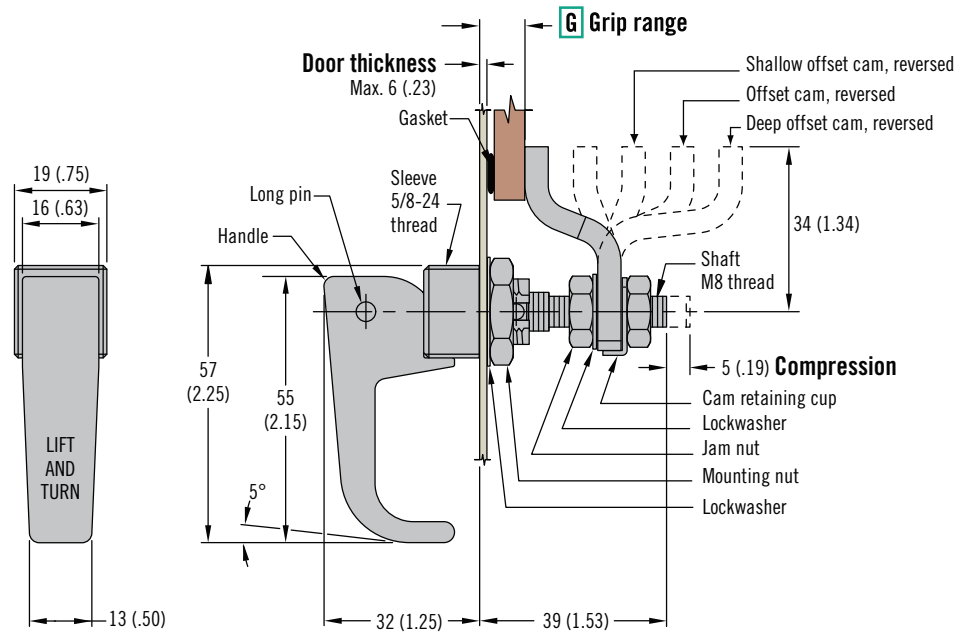

### Part Number Selection

**62 - 10 - G F**

G Grip	Min.	Max.	Cam Type
1	42 (1.66)	52 (2.05)	Deep offset cam, forward
	2 (.08)	12 (.47)	Offset cam, forward
2	32 (1.25)	42 (1.66)	Offset cam, reversed
	12 (.47)	22 (.87)	Shallow offset cam, forward
3	22 (.87)	32 (1.25)	Shallow offset cam, reversed

**F Finish**

- 1 Polished chrome
- 2 Brushed chrome
- 3 Natural with chemical protective film
- 5 Black powder coated