



62 Compression Latch

Large · Lift & turn series · Flush style · Adjustable grip

- Low profile when latched
- Easy grip adjustment
- Intuitive operation

Material and Finish

Zinc alloy, chrome brushed and steel, zinc plated

Performance Details

Max. static load: 1250 N (280 lbf)

Installation Notes

*Screw and lockwasher assembly 5/16-18UNC x 3/4.
For door thickness greater than 6 (.25) calculate screw length using the following formula:
Door thickness + 7 (.28)

Accessories

Actuator for three point locking assembly (order separately)
Part number: 62-19-501-15



Keys

See page 58

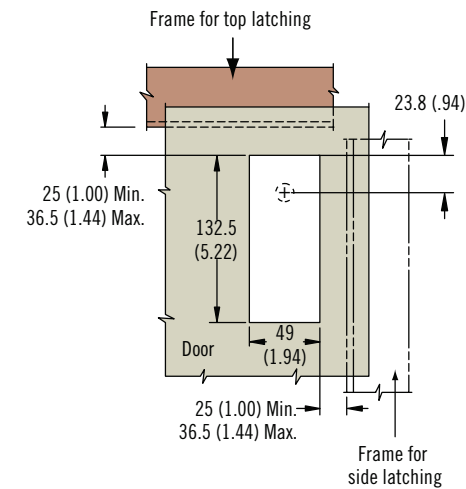
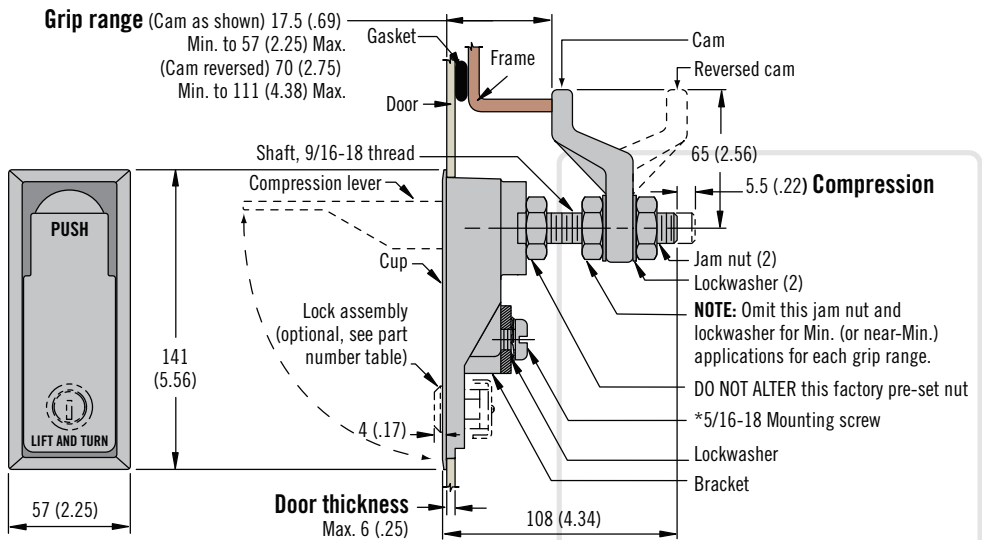

ACTUAL SIZE

Part Number Selection

- H** Head style
- 0 Non-locking
 - 1 Key-locking keyed alike CH751 (two flat keys supplied)

62 - 10 - 8 **H** 1 - 20

Dimensions in millimeters (inch) unless otherwise stated