

# Southco® Compression Latches

## Spring Latch Series

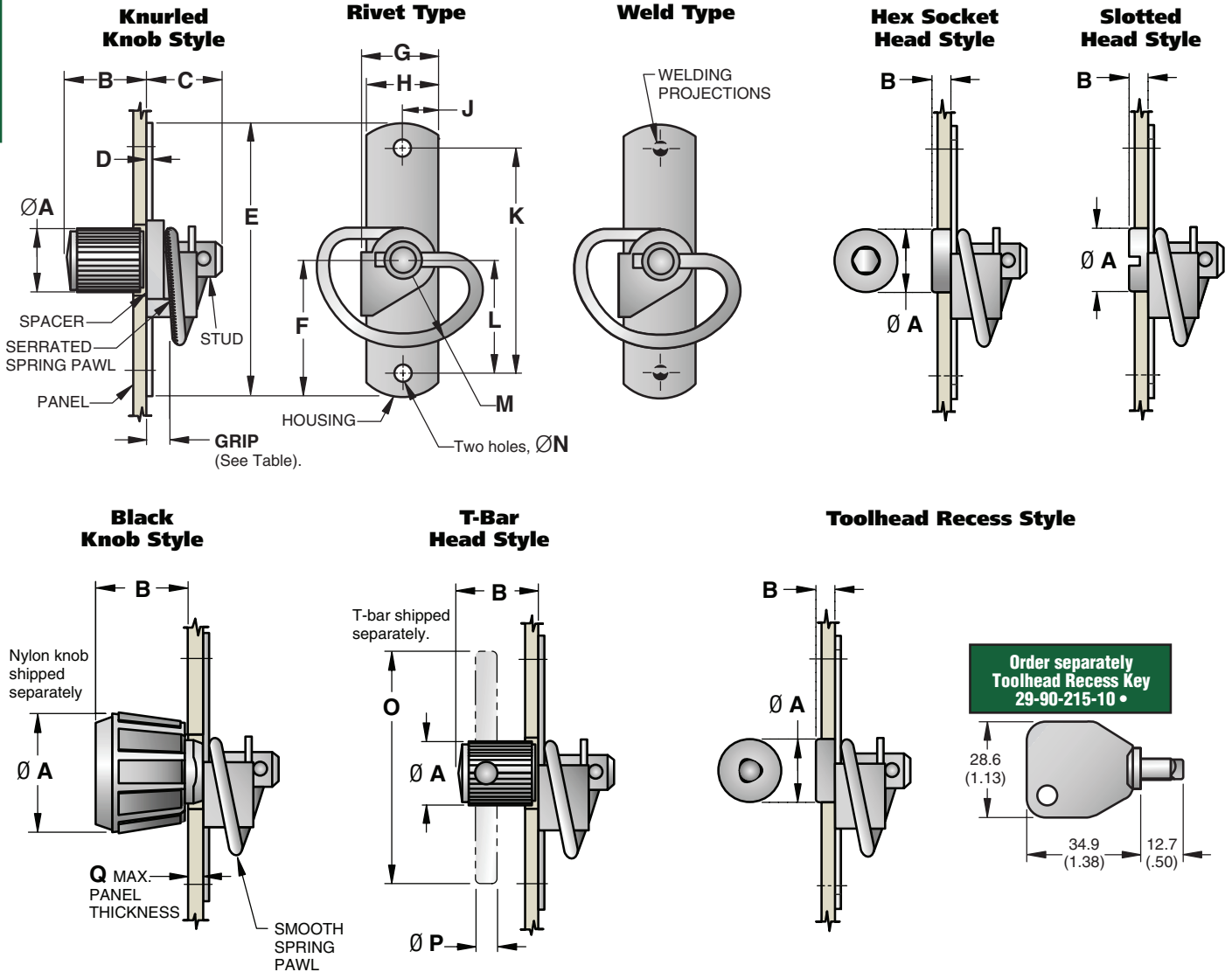

### Dimension table

SIZE	HEAD STYLE	DIMENSIONS																
		Ø A	B	C	D	E	F	G	H	J	K	L	M	N	O	P	Q MAX. Panel Thickness	
Mini	Knurled	6.6 (.26)	11.9 (.47)	7.5 (.30)	0.8 (.031)	27 (1.06)	13.5 (.53)	8.5 (.33)	7.1 (.28)	3.6 (.14)	22.2 (.875)	11.1 (.438)	8.6 (.34)	2.7 (.106)	—	—	—	
	Slotted	6.4 (.25)	1.6 (.06)															
	Black Knob	13.5 (.53)	11.9 (.47)															3.2 (.125)
Small	Knurled	9.7 (.38)	11.9 (.47)	11.1 (.44)	0.8 (.031)	39.7 (1.56)	19.8 (.78)	11.6 (.458)	10.6 (.416)	5.3 (.208)	33.3 (1.312)	16.7 (.656)	13 (.51)	2.7 (.106)	—	—	—	
	Slotted	9.5 (.38)	2.4 (.09)															
	Black Knob	14.7 (.58)	15.1 (.59)															4.8 (.188)
Medium	Knurled	13.7 (.54)	17.5 (.69)	17.5 (.69)	1.3 (.05)	58.7 (2.31)	29.4 (1.16)	17.5 (.69)	15.8 (.62)	7.9 (.31)	49.2 (1.94)	24.6 (.97)	19.6 (.77)	3.5 (.136)	—	—	—	
	Slotted	11.9 (.47)	3.2 (.13)															
	Black Knob	24.1 (.95)	19.1 (.75)															6.4 (.250)
	Hex (4mm socket)	11.9 (.47)	3.2 (.13)															
	T-bar	13.7 (.54)	17.5 (.69)															50.8 (2.0)
Toolhead Recess	14.3 (.56)	4.6 (.18)	—	—														
Large	Slotted	19.1 (.75)	4.8 (.19)	25 (.98)	1.9 (.075)	88.9 (3.50)	44.5 (1.75)	26.2 (1.03)	23.8 (.94)	11.9 (.47)	74.6 (2.94)	37.3 (1.47)	29 (1.14)	5.2 (.203)	—	—	—	
	Black Knob	28.2 (1.11)	21.6 (.85)															7.9 (.313)
	Hex (8mm socket)	19.1 (.75)	4.8 (.19)															
	T-bar	19.4 (.76)	26.2 (1.03)	63.5 (2.5)	6.4 (.25)													



**Part number table**

GRIP	SIZE	TYPE	SPRING STYLE	PART NUMBERS					
				HEAD STYLE					
				KNURLED	HEX SOCKET	SLOTTED	BLACK KNOB	T-BAR	TOOL-HEAD RECESS
1.2 (.05) MIN. 4.3 (.17) MAX.	Mini	Rivet	Smooth	57-20-201-10 •	————	57-20-101-10 •	57-20-401-10 •	————	————
		Weld	Smooth	57-20-202-50	————	57-20-102-50 •	————	————	————
1.2 (.05) MIN. 6.4 (.25) MAX.	Small	Rivet	Smooth	57-30-201-10 •	————	57-30-101-10 •	57-30-401-10 •	————	————
		Weld	Smooth	57-30-202-50 •	————	57-30-102-50 •	57-30-402-50 •	————	————
1.6 (.06) MIN. 9.5 (.38) MAX.	Medium (Steel)	Rivet	Smooth	57-10-201-10 •	57-10-801-10 •	57-10-101-10 •	57-10-401-10 •	57-10-301-10 •	————
			Serrated	57-10-211-10 •	57-10-811-10 •	57-10-111-10 •	57-10-411-10 •	57-10-311-10 •	57-T-10 •
	Weld	Smooth	57-10-202-50 •	57-10-802-50 •	57-10-102-50 •	57-10-402-50 •	————	————	
		Serrated	57-10-212-50 •	————	57-10-112-50 •	57-10-412-50	57-10-312-50 •	————	
Medium (Stainless)	Rivet	Smooth	57-10-201-40 •	————	57-10-101-40 •	————	————	————	
	Weld	Smooth	57-10-202-40 •	————	57-10-102-40 •	————	————	————	
6.4 (.25) MIN. 14.3 (.56) MAX.	Medium with Spacer	Rivet	Smooth	57-10-203-10 •	————	57-10-103-10 •	57-10-403-10 •	————	————
2.4 (.09) MIN. 14.3 (.56) MAX.	Large	Rivet	Smooth	————	57-40-801-10 •	57-40-101-10 •	57-40-401-10 •	57-40-301-10 •	————
			Serrated	————	57-40-811-10 •	57-40-111-10 •	57-40-411-10 •	57-40-311-10 •	————

**Material and Finish**

**Steel Assemblies**

**KNOB:** Nylon, black.  
**SPRING:** 302 Stainless steel, passivated.  
**HOUSING:** 1010 Steel; rivet style-zinc plate, chromate plus sealer, weld style-copper plated.  
**T-BAR, T-BAR STUD and HEX DRIVE STUD:** Low carbon steel, zinc plated.  
**BLACK KNOB STUD:** Low carbon steel, zinc immersion coating.  
**OTHER STUDS:** Low carbon steel, zinc plate, chromate plus sealer.  
**TOOLHEAD RECESS KEY:** Case hardened steel with bright nickel plate.  
**SPACER:** Steel, zinc alloy plate, bright chromate plus sealer.

**All Stainless Steel Assemblies**

**SPRING and HOUSING:** 302 Stainless steel, passivated.  
**STUDS:** 303 Stainless steel, passivated.

**Product Strength Guidelines**

(To assist in your product selection; samples are available for your evaluation.)

**Flammability Rating**

(Nylon knob): UL94 - HB

**Operating Temperature Range**

(Nylon knob): -20°C (0°F) to 80°C (180°F)

millimeter (inch)  
 millimeter  
 (inch)

Dimensions without tolerances are for reference only.

## Installation

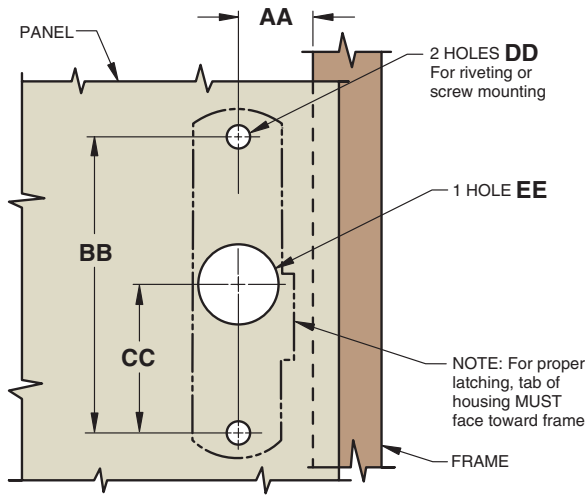

SIZE	HEAD STYLE	DIMENSIONS				
		AA	BB $\pm 0.1$ ( $\pm .005$ )	CC $\pm 0.1$ ( $\pm .005$ )	$\varnothing$ DD	$\varnothing$ EE
Mini	All Styles	5.6 (.22)	22.2 (.875)	11.1 (.438)	2.7 (.106)	7.2 (.283)
Small	All Styles	8.7 (.34)	33.3 (1.312)	16.7 (.656)	2.7 (.106)	10.5 (.406)
Medium	Knurled	12.7 (.50)	49.2 (1.938)	24.6 (.969)	3.5 (.136)	14.5 (.563)
	Slotted					13 (.50)
	Black Knob					16 (.625)
	Hex					13 (.50)
	T-bar					14.5 (.563)
	Toolhead					15.1 (.594)
Large	Black Knob	19.1 (.75)	74.6 (2.937)	37.3 (1.469)	5.2 (.20)	21 (.812)
	Bail Handle					12.5 (.484)
	All Other Styles					20 (.781)

### Knurled Knob

### Black Knob Style

NOTE: Install Knob AFTER installing latch.

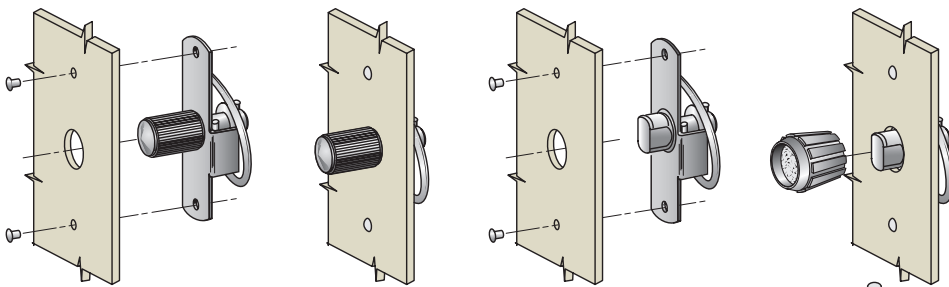

### Hex Socket, Slotted and Tool-head Styles

### T-Bar Style

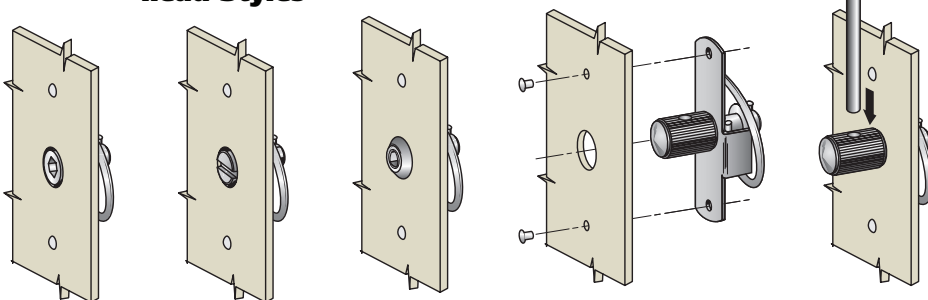

millimeter (inch)  
millimeter  
(inch)

Dimensions without tolerances are for reference only.