

# Southco® Pawl/Cam Action Latches

## Flush T-handle Series, Heavy Duty Style

- T-handle folds away
- Adjustable grip style allows for flexibility in the amount of compression applied
- Fixed-grip style provides consistent compression

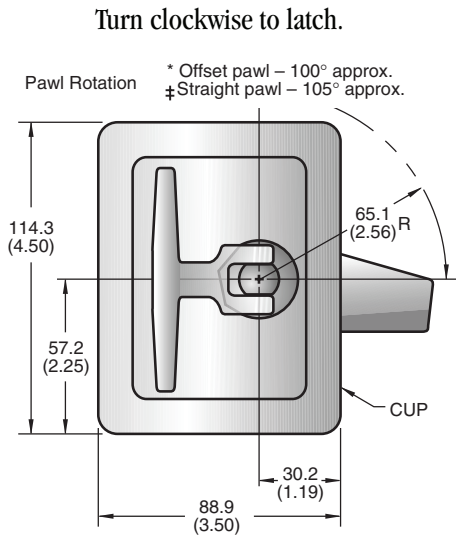

### Adjustable-grip

Turn handle 90° to latch/unlatch.  
Additional turns to pull up tighter,  
compress a gasket.

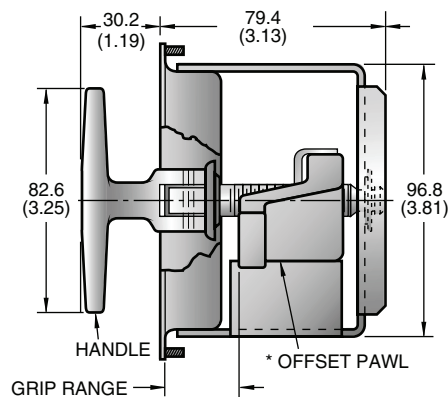

### Fixed Grip

Loosen jam nuts to adjust pawl to exact grip.  
Tighten jam nuts to lock pawl in position.

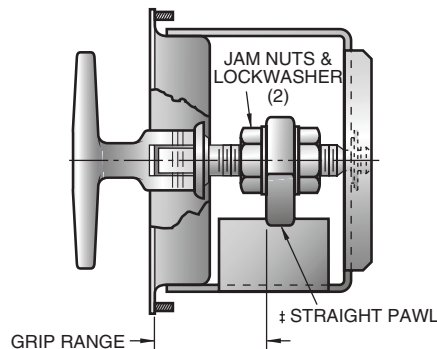
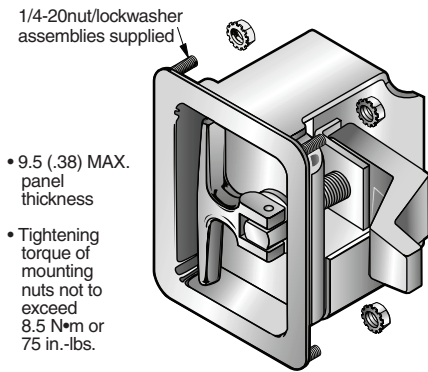

### Panel Preparation

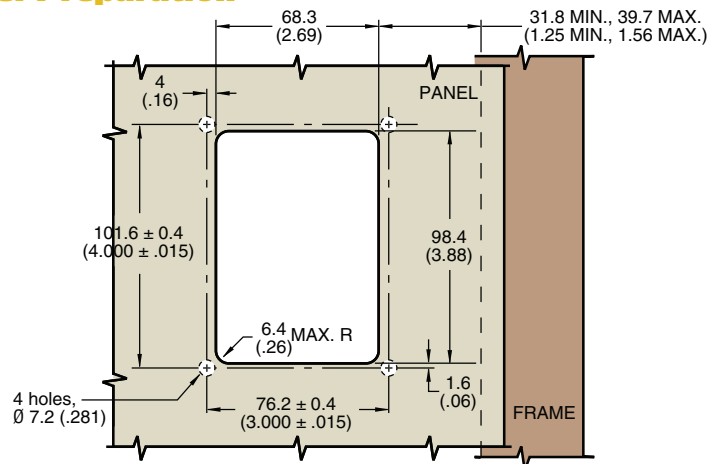

### Material and Finish

CUP, BRACKET and CUP WASHER: 1010 Steel;  
HANDLE: Die-cast zinc; SCREW: Low carbon steel;  
STRAIGHT PAWL: 1008 Steel; these components are zinc immersion coating. GROOVE PIN: 1112 Steel, zinc plate, chromate plus sealer.  
CURVED PAWL: Die-cast zinc plus chemical protective coating. WEAR WASHER: Nylon, natural.  
CONICAL SPRING: Spring wire, zinc plate, chromate plus sealer. C-RETAINER: Steel, zinc plated plus chromate dip.  
MOUNTING STUDS: Steel, zinc immersion coating.  
NUT/LOCKWASHER ASSEMBLIES: NUT: 1020 Steel; LOCKWASHER: Steel; both are zinc plate, chromate plus sealer.  
For fixed grip model  
LOCKWASHERS: Steel, zinc plated plus chromate dip.  
JAM NUTS: Steel, zinc plate, chromate plus sealer.  
For adjustable-grip models  
PAWL SPRING: 304 Stainless steel, passivated

### Product Strength Guidelines

(To assist in your product selection; samples are available for your evaluation.)

Force applied to pawl where it contacts frame

\*Offset pawl:

Maximum static load: 2670 N (600 lbs.)

‡Straight pawl:

Maximum static load: 1335 N (300 lbs.)

Average ultimate load (Both Pawl Types): 4450 N (1000 lbs.)

### Adjustable-grip

GRIP RANGE		PART NUMBERS
MIN.	MAX.	
19 (.75)	28.6 (1.13)	24-20-601-10*
28.6 (1.13)	58.7 (2.31)	24-20-602-10‡ •

### Fixed Grip

GRIP RANGE		PART NUMBERS
MIN.	MAX.	
17.5 (.69)	20.6 (.81)	24-20-621-10*
31.8 (1.25)	49.2 (1.94)	24-20-622-10‡
59.5 (2.34)	62 (2.44)	24-20-623-10*

millimeter (inch)  
millimeter  
(inch)

Dimensions without tolerances are for reference only.

# Southco® Pawl/Cam Action Latches

## Flush T-handle Series, Fixed-grip Style

- T-handle folds away
- Use with single-, 2-, or 3-point latching (See pages 160 to 164)
- Keylocking version available
- Available with or without mounting studs

TYPE A Assembly Illustrated

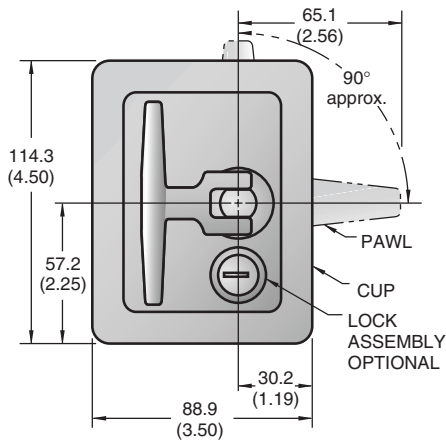

### Grip Range

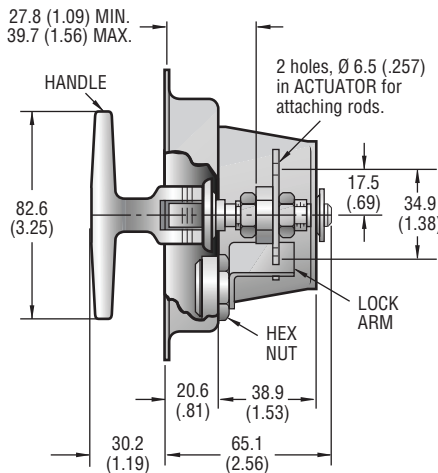

### Panel Preparation

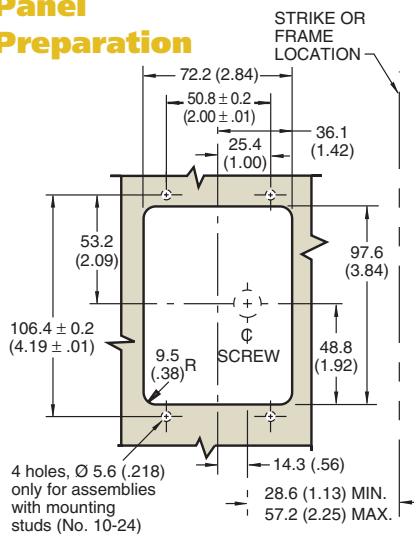

### No. 24 Flush Latches with mounting studs

(mounting nuts and lockwashers supplied)

#### FLANGE GASKET OPTIONAL

- 7.9 (.31) MAX. panel thickness
- Tightening torque of mounting nuts not to exceed 2.8 N·m or 25 in.-lbs.

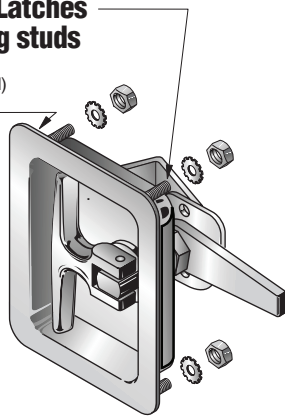

### Material and Finish

#### For all models

ACTUATOR and PAWL: 1010 Steel, zinc immersion coating. GROOVE PIN: 1112 Steel, zinc plate, chromate plus sealer. CONICAL SPRING: Steel, spring wire, zinc plate, chromate plus sealer. LOCKWASHERS and MOUNTING NUTS (for models with mounting studs): Steel. JAM NUTS: Steel, zinc plate, chromate plus sealer. C-RETAINER: Steel, zinc plated plus chromate dip. U-- BENT WASHER: 1070 or 1080 Steel. These components are zinc plated plus chromate dip. SHAFT and FLANGE GASKETS (for dust and moisture sealed models): Neoprene, black. LOCK PLUG and LOCK CYLINDER: Die-cast zinc, chrome plated. SPACER: Low carbon steel, zinc immersion coating. LOCK ARM: 1010 Steel, zinc immersion coating. SCREW: Steel, zinc plated plus chromate dip. HEX NUT: Die-cast zinc with chemical protective coating. KEYS: Brass, nickel plated.

#### For assemblies with a stainless steel cup

CUP and BRACKET: 302 Stainless steel, highly polished. MOUNTING STUDS: (optional): 302 or 305 Stainless steel, full bright annealed. SCREW: 12L14TE Steel. HANDLE: Die-cast zinc. CUP WASHER: 1010 Steel. These components are chrome plated.

#### For assemblies with a steel cup

CUP, BRACKET and CUP WASHER: 1010 Steel. MOUNTING STUDS (optional): Steel. SCREW: Low carbon steel. HANDLE: Die-cast zinc. Components listed above are zinc immersion coated.

### Product Strength Guidelines

(To assist in your product selection; samples are available for your evaluation.)

Force applied to pawl where it contacts frame  
Maximum static load: 445 N (100 lbs.)  
Average ultimate load: 1110 N (250 lbs.)

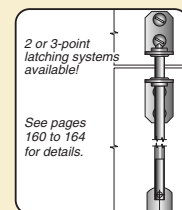

millimeter (inch)  
millimeter  
(inch)

Dimensions without tolerances are for reference only.

STYLE	PART NUMBERS					
	WITH MOUNTING STUDS				WELD	
	CUP and BRACKET: Polished stainless steel. HANDLE: Die cast zinc, chrome plated.	CUP and BRACKET: Steel, DACROTIZED†.	CUP and BRACKET: Steel, DACROTIZED†.	CUP and BRACKET: Steel, DACROTIZED†.	CUP and BRACKET: Steel, DACROTIZED†.	CUP and BRACKET: Steel, DACROTIZED†.
	TYPE A	TYPE B	TYPE A	TYPE B	TYPE A	TYPE B
WITH KEYLOCK (keyed alike)*	24-20-812-35 •	24-20-912-35 •	24-20-812-10 •	24-20-912-10 •	24-10-812-10 •	24-10-912-10 •
WITHOUT KEYLOCK	24-20-302-35 •	24-20-402-35 •	24-20-302-10 •	24-20-402-10 •	24-10-302-10 •	24-10-402-10 •
WITHOUT KEYLOCK	DUST AND MOISTURE SEALED (Neoprene gasketed shaft and cup flange)					
	24-20-312-35 •	24-20-412-35 •	24-20-312-10 •	24-20-412-10 •		

Locks are keyed alike. Different key codes are available.

TYPE A Assemblies turn clockwise to latch. TYPE B Assemblies turn counter clockwise to latch.

southco®

• Products identified with this symbol are stocked subject to prior sale in one or more of our global locations. If unavailable from our facility nearest you, allow for shipping time from another facility.