

REV.	MODIFICATION.	DATE	DRN
01	PRODUCTION RELEASE	18/01/07	OW
02	ECN2007-132	10/08/07	OW
03	ECN2007-238	17/12/07	SF
04	CO 2011188	17/08/11	NB

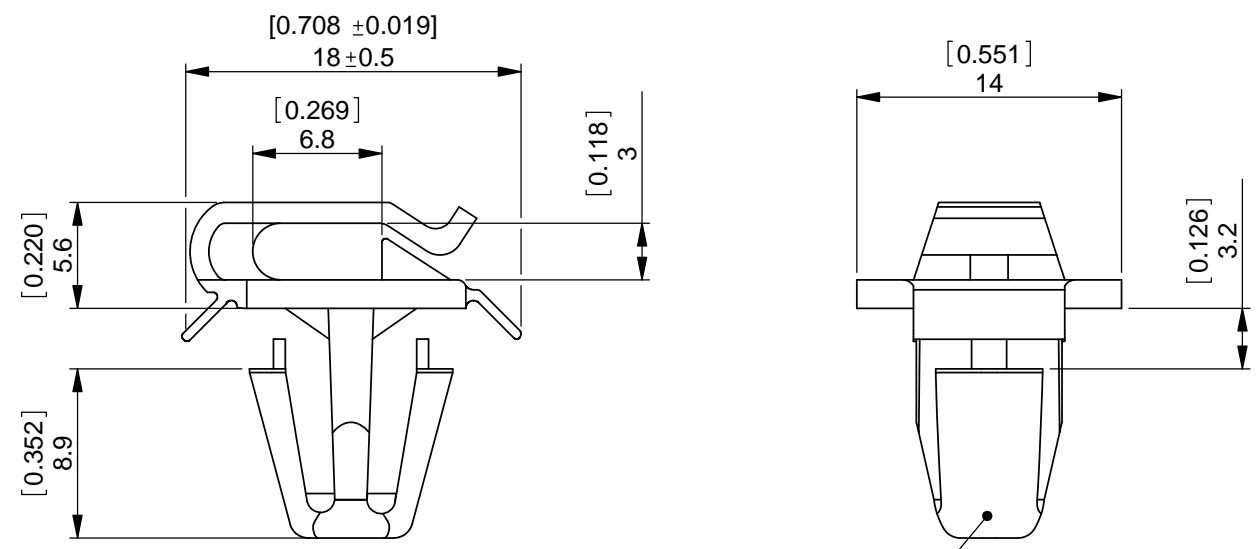

TO SNAP LOCK INTO A $\varnothing 8 \pm 0.2$ [0.314 ± 0.007] HOLE, INTO A 1.6 - 2.6 [0.062 - 0.102] THICK PANEL.

ALTERNATE DIMENSIONS FOR REFERENCE ONLY

INFORMATION CONTAINED IN THIS DOCUMENT IS CONFIDENTIAL TO RICHCO INTERNATIONAL Co. Ltd. AND MAY NOT BE DISCLOSED OR REPRODUCED IN WHOLE OR PART WITHOUT THEIR WRITTEN CONSENT.

RICHCO, INC.
WWW.RICHCO-INC.COM

PRIMARY DIMENSIONS IN mm
SECONDARY DIMENSIONS IN IMPERIAL [inches]
GENERAL TOLERANCES ± 0.25 [0.0010]
UNLESS OTHERWISE STATED
1 DECIMAL PLACE \pm
2 DECIMAL PLACES \pm
ANGULAR $\pm 1^\circ$

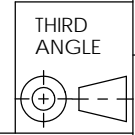

NOTES:

1) PARTS ALSO AVAILABLE IN RMS-19 & RMS- 47 BLACK, MATERIAL BY SPECIAL ORDER.
ADD -19, -109 & -47BK TO END OF PART NUMBER:

WS-SE3-19/ WS-SE3-109/ WS-SE3-47BK.

2) PART AVAILABLE in RMS-01 BLACK TO ORDER USE PART NUMBER: WS-SE3-1-01BK

MATERIAL: NYLON 6/6 UL 94 V2 (RMS-01)		COLOUR: NATURAL	
DESCRIPTION: WIRE SADDLE, SIDE ENTRY		PART No: WS-SE3-1-01	
DRG No: 07-008	NPR No: 2006-172	Mass:(g) 0.9	SHEET SIZE A4
DRN OW	DATE 02/06/06	CHKD NB	DATE 02/06/06
SCALE NTS		SHEET No. 1 OF 1	