

CABLE TIES & ACCESSORIES

WIT-RA/SA Arrowhead Ties

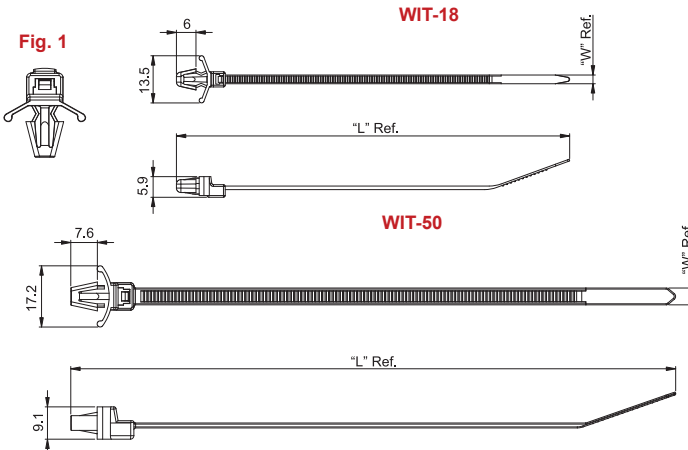

Standard Material: UL94 V-2 Nylon 6/6, RMS-01 Color: Natural	Fig.	Min. Loop Tensile Strength (Kg)	"W"	"L" Ref.	Max. Bundle Ø	Hole Ø	Panel Thickness	Color & Material Variations Suffix				Standard Pack
								UL94 V-0 Nylon 6/6, RMS-75 Color: Natural	UL94 V-2 Nylon 6/6, RMS-01 Color: Black	High Temp. UL94 V-2 Nylon 4/6, RMS-109 Color: Natural	UL94 V-2 UV Stabilized Nylon 6/6, RMS-46 Color: Black	
								Replace -01 with V-0	Add "BK"	Add "-HT"	Add "-UVB"	
WIT-18RA-01	1	8	2.5	109	21	4.8	1.6	-	-	-	-	1000
WIT-50SA-01				133	23			Special Order 50K MOQ	Special Order 50K MOQ	Special Order 50K MOQ	Special Order 50K MOQ	
WIT-50SRA-01				173	36							
WIT-50RA-01				198	43							
NEW WIT-50SA-1-01	2	22	4.8	133	23	6.4 - 6.8	0.8 - 2	Special Order 50K MOQ	Special Order 50K MOQ	Special Order 50K MOQ	Special Order 50K MOQ	500
NEW WIT-50SRA-1-01				173	36							1000
NEW WIT-50RA-1-01				198	43							500

WIT-18RA Self-Mount Ties



• UL #E71558

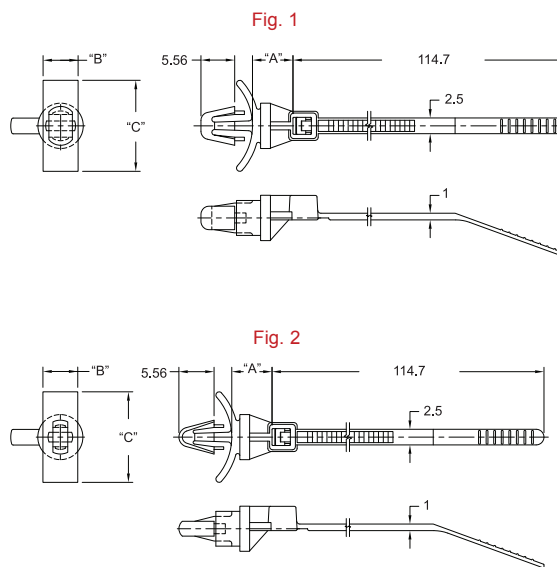

Standard Pack: 1000/Bag									
Material: UL94 V-2 Nylon 6/6, RMS-01 Color: Natural	Min. Loop Tensile Strength (Kg)	Max. Bundle Ø	"A"	"B"	"C"	Hole Ø ± 0.08	Panel Thickness	UL94 V-2 UV Stabilized Nylon 6/6, RMS-46 Color: Black	Figure
WIT-18RA-4-01-M	8	19.1	6.4	5.56	14.29	4.75	0.8 - 2	-UVB-M	1
WIT-18R1A-4-01-M						4		Special	2
WIT-18R2A-4-01-M				2.79	13.9	4.75	1.6 - 3.6	1	