

REV.	MODIFICATION.	DATE	DRN
01	CO2010267	24/09/08	SF
02	CO2010790	26/08/09	PH

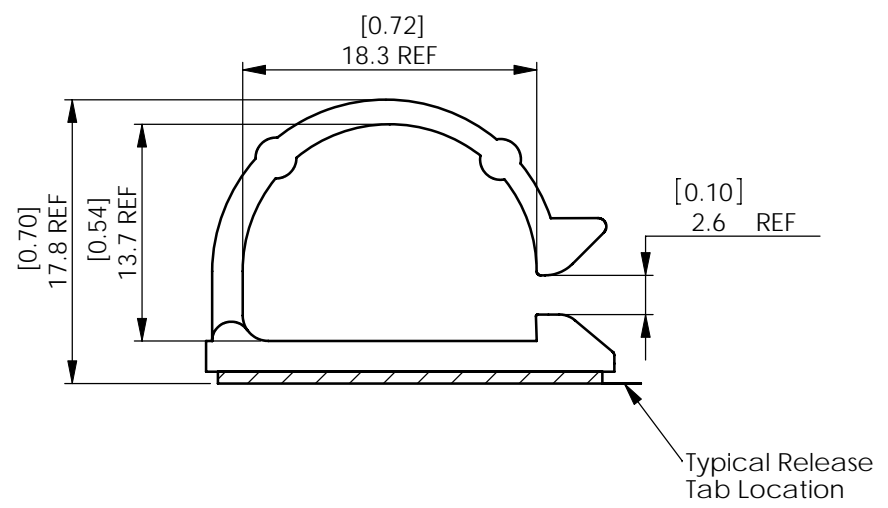
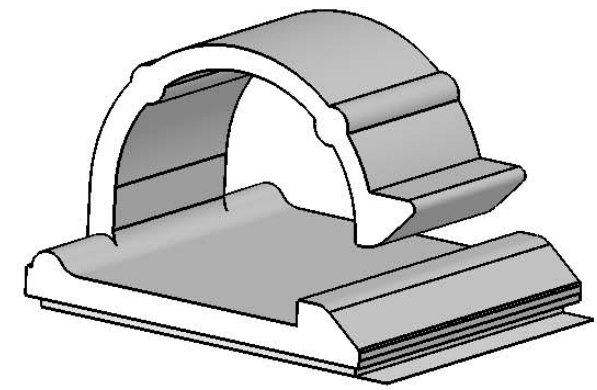
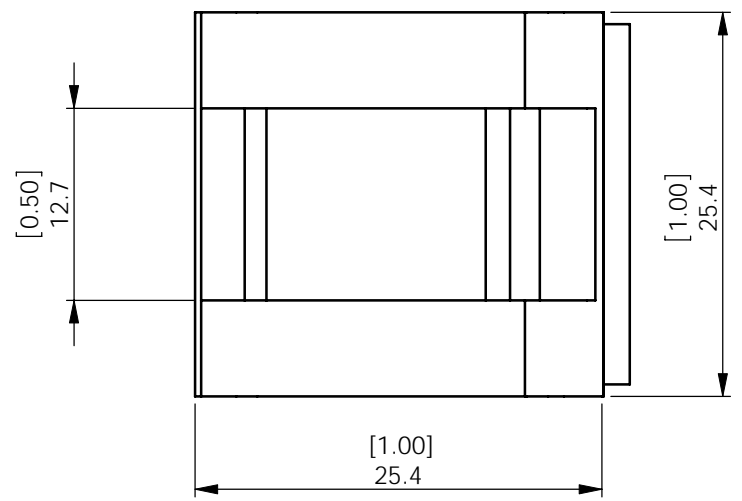

ALTERNATE UNITS FOR REFERENCE ONLY

INFORMATION CONTAINED IN THIS DOCUMENT IS CONFIDENTIAL TO RICHCO INTERNATIONAL Co. Ltd. AND MAY NOT BE DISCLOSED OR REPRODUCED IN WHOLE OR PART WITHOUT THEIR WRITTEN CONSENT.

**RICHCO, INC.**  
WWW.RICHCO-INC.COM

ALL DIMENSIONS IN mm  
GENERAL TOLERANCES  $\pm 0.25$   
UNLESS OTHERWISE STATED  
1 DECIMAL PLACE  $\pm$   
2 DECIMAL PLACES  $\pm$   
ANGULAR  $\pm 1^\circ$

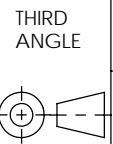

MATERIAL:  
Nylon 6/6 UL94 V-2 (RMS-01)

COLOUR:  
Natural

DESCRIPTION:  
WIRE CORD KLIP

PART No:  
WCK-720-01A4-RT

DRG No:  
08-099

NPR No:  
XXXX-XXX

SHEET SIZE  
A4

DRN  
SF

DATE  
24/09/08

CHKD  
TC

DATE  
24/08/09

SCALE  
NTS

SHEET No.  
1 OF 1

- NOTES:
1. NYLON 6/6 UL94 V-0 (RMS-19), AVAILABLE BY SPECIAL ORDER ONLY. TO ORDER REPLACE SUFFIX "01" WITH "19".
  2. 0.8 [1/32"] THICK DOUBLE SIDED ACRYLIC ADHESIVE (RMS-324)
  3. AVAILABLE 'WITHOUT' TAPE BY SPECIAL ORDER ONLY. TO ORDER REMOVE SUFFIX "A4-RT"