

REV.	MODIFICATION.	DATE	DRN
01	NEW DRAWING	19/10/04	NJB
02	ECN2005-075	21/06/05	OW
03	CO2011185	05/08/11	SF

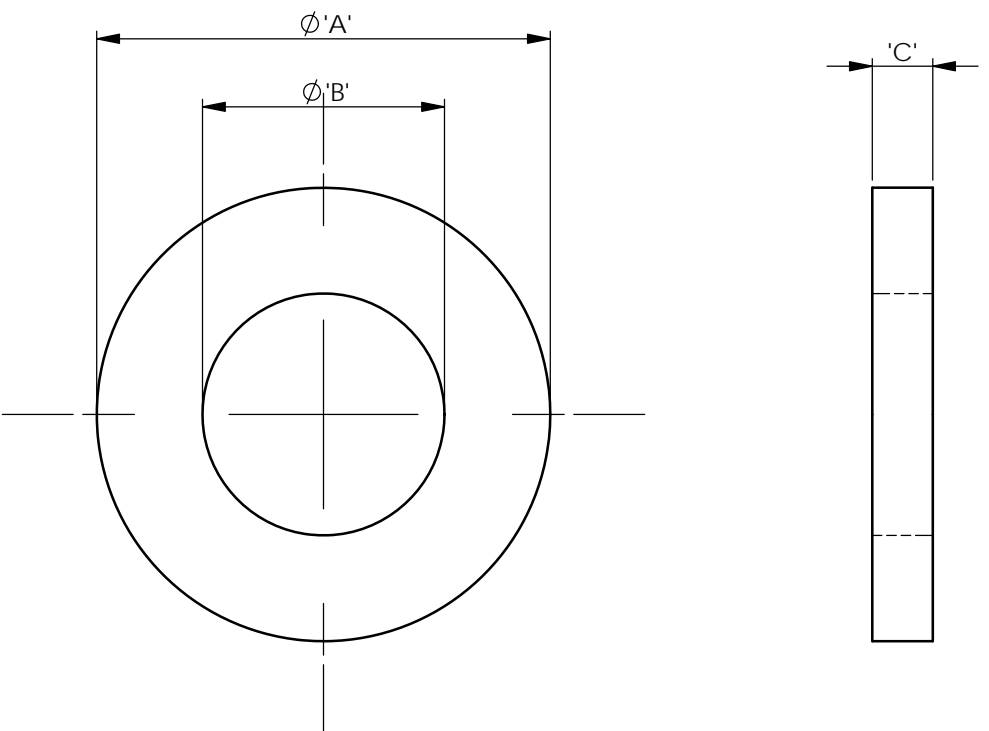

**AVAILABLE BY SPECIAL ORDER-NAFTA REGION ONLY**

PART NUMBER	THREAD	$\phi A$	$\phi B$	C
NWE-34815-M2	M2	4.9(-0.36 +0) [.193(-.014 +0)]	2.5 (-0 +0.18) [.098 (-0 +.007)]	0.35 ( $\pm 0.05$ ) [.0137 ( $\pm .020$ )]
NWE-34815-M2.5	M2.5	6.5(-0.36 +0) [.256(-.014 +0)]	2.7(-0 +0.18) [.107(-0 +0.18)]	0.5(+0.05) [.020(+.002)]
NWE-34815-M3	M3	7.0(-0.36 +0) [.276(-.014 +0)]	3.2(-0 +0.18) {.126(-0 +.007)}	
NWE-34815-M4	M4	9.0(-0.36 +0) [.355(-.014 +0)]	4.3(-0 +0.18) [.170(-0 +.007)]	0.8( $\pm 0.1$ ) [.032( $\pm .004$ )]
NWE-34815-M5	M5	10.0(-0.36 +0) [.394(-.014 +0)]	5.3(-0 +0.18) [.209 (-0 +.007)]	1.0( $\pm 0.1$ ) [.040 ( $\pm .004$ )]
NWE-34815-M6	M6	12.0 (-0.43 +0) [.473 (-.017 +0)]	6.4 (-0 +0.22) [.252(-0 +.009)]	1.6( $\pm 0.2$ ) [.063 ( $\pm .008$ )]

**NOTES:**

1) PART PRODUCED ACCORDING TO DIN-34815.

ALTERNATE UNITS FOR REFERENCE ONLY

*INFORMATION CONTAINED IN THIS DOCUMENT IS CONFIDENTIAL TO RICHCO INTERNATIONAL Co. Ltd. AND MAY NOT BE DISCLOSED OR REPRODUCED IN WHOLE OR PART WITHOUT THEIR WRITTEN CONSENT*

**RICHCO, INC.**  
[WWW.RICHCO-INC.COM](http://WWW.RICHCO-INC.COM)

METRIC GENERAL TOLERANCES  $\pm 0.25$   
 ARE PRIMARY UNLESS OTHERWISE STATED  
 1 DECIMAL PLACE  $\pm$   
 2 DECIMAL PLACES  $\pm$   
 ANGULAR  $\pm 1^\circ$

IMPERIAL GENERAL TOLERANCES  $\pm 0.010$   
 ARE FOR REFERENCE UNLESS OTHERWISE STATED  
 1 DECIMAL PLACE  $\pm$   
 2 DECIMAL PLACES  $\pm$   
 ANGULAR  $\pm 1^\circ$

MATERIAL: **NYLON 6/6 (RMS-174)**      COLOUR: **NATURAL**

TITLE: **WASHER**      PART No: **SEE TABLE**

DRG No: **04-119**      NPR REF:           SIZE **A4**

DRN NJB	DATE 19/10/04	CHKD I.C	DATE 19/10/04	SCALE NTS	SHEET No 1 OF 1
------------	------------------	-------------	------------------	--------------	--------------------