

REV.	MODIFICATION.	DATE	DRN
01	ECN2008-011	16/01/08	SF
02	CO2010945	22/06/10	SF

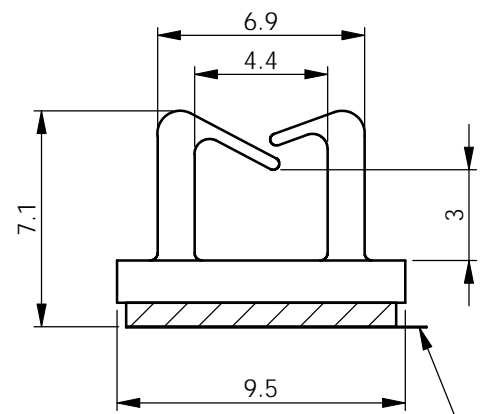

TYPICAL RELEASE TAB LOCATION.

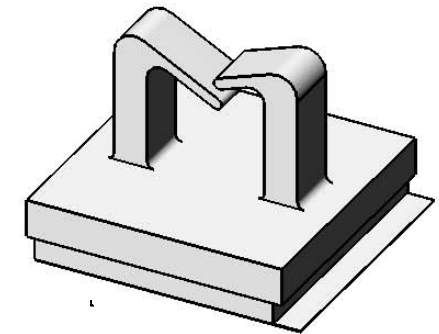
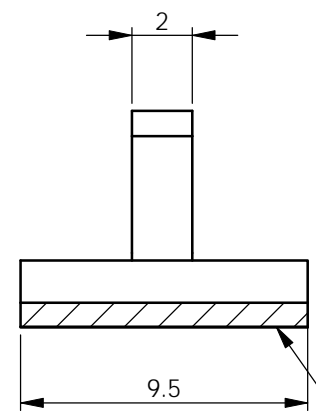

SEE NOTE FOR ADHESIVE DETAILS.

NOTE:

- ADHESIVE DETAILS AS FOLLOWS:ADHESIVE TAPE, PE FILM LINER.(RMS-24)
- THE COLOUR OF THE ADHESIVE LINER MAY VARY. THIS WILL NOT AFFECT THE TECHNICAL PROPERTIES OF THE PART.

ALTERNATE UNITS FOR REFERENCE ONLY

INFORMATION CONTAINED IN THIS DOCUMENT IS CONFIDENTIAL TO RICHCO INTERNATIONAL Co. Ltd. AND MAY NOT BE DISCLOSED OR REPRODUCED IN WHOLE OR PART WITHOUT THEIR WRITTEN CONSENT.

PART NUMBER	MATERIAL
MWSB-1-01A2-RT	NYLON 6/6 UL94 V-2(RMS-01)
MWSB-1-19A2-RT	NYLON 6/6 UL94 V0(RMS-19)

RICHCO, INC. WWW.RICHCO-INC.COM	ALL DIMENSIONS IN mm GENERAL TOLERANCES ± 0.25 UNLESS OTHERWISE STATED 1 DECIMAL PLACE ± 0.25 2 DECIMAL PLACES ± 0.10 ANGULAR $\pm 1^\circ$	THIRD ANGLE
	MATERIAL: SEE TABLE COLOUR: NATURAL	

DESCRIPTION: MICRO WIRE SADDLE ON ADHESIVE BASE
 PART No: SEE TABLE

DRG No: 2008-006	NPR No: N/A	Mass:(g) 0.8	SHEET SIZE A4
---------------------	----------------	-----------------	------------------

DRN SF	DATE 16/01/08	CHKD TC	DATE 16/01/08	SCALE NTS	SHEET No. 1 OF 1
-----------	------------------	------------	------------------	--------------	---------------------