

REV.	MODIFICATION.	DATE	DRN
01	ECN2008-008	11/01/08	SF
02	CO2010518	17/12/08	SF
03	CO2010804	07/09/09	MT
04	CO2011060	16/02/11	SF
05	CO2011255	18/04/12	SF
06	CO2011260	03/07/12	SF

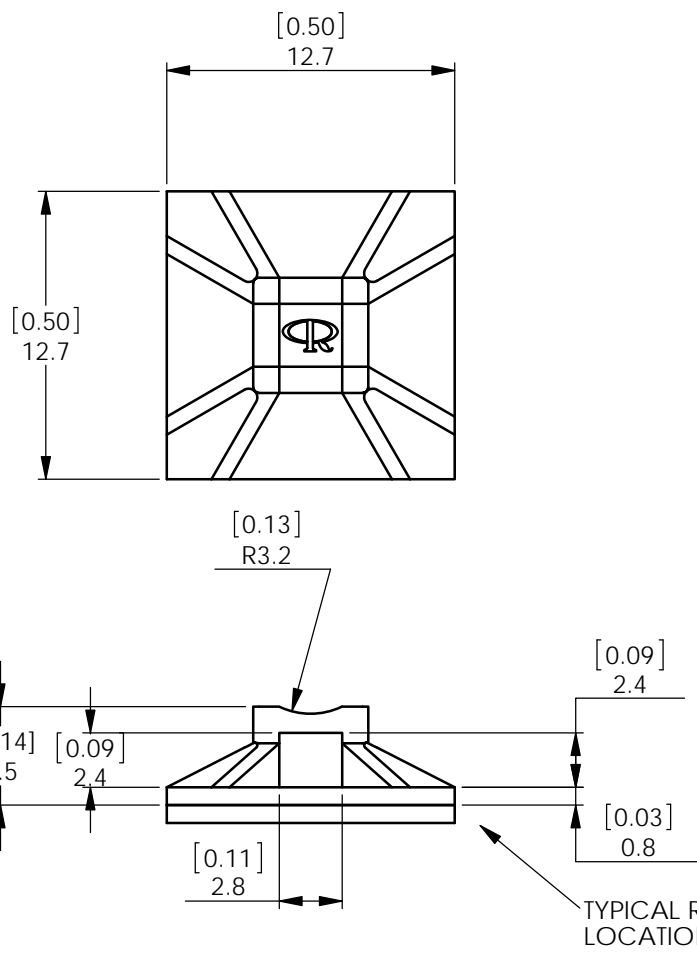

ALTERNATE UNITS FOR REFERENCE ONLY

INFORMATION CONTAINED IN THIS DOCUMENT IS CONFIDENTIAL TO RICHCO INTERNATIONAL Co. Ltd. AND MAY NOT BE DISCLOSED OR REPRODUCED IN WHOLE OR PART WITHOUT THEIR WRITTEN CONSENT.

PART NUMBER	ADHESIVE
MFTH-2-01A1-M	0.8[0.03] THICK, DOUBLE SIDED RUBBER ADHESIVE (RMS-102)
MFTH-2-01A4-RT-M	0.8[0.03] THICK, DOUBLE SIDED RUBBER ADHESIVE (RMS-024)
PARTS AVAILABLE IN UL94 V-0 NYLON 6/6 (RMS-19) AND UV STABILIZED NYLON 4/6(RMS-46) BY SPECIAL ORDER	
AVAILABLE WITHOUT TAPE BY SPECIAL ORDER.	

<b>RICHCO, INC.</b> WWW.RICHCO-INC.COM		ALL DIMENSIONS IN mm GENERAL TOLERANCES ±0.25 UNLESS OTHERWISE STATED 1 DECIMAL PLACE ± 2 DECIMAL PLACES ± ANGULAR ±1°	THIRD ANGLE 
MATERIAL: NYLON 6/6 UL94 V-2(RMS-01)		COLOUR: NATURAL	
DESCRIPTION: FLAT TIE HOLDER		PART No: SEE TABLE	
DRG No: 2008-005		NPR No: N/A	
		SHEET SIZE A4	
DRN SF	DATE 11/01/08	CHKD TC	DATE 16/01/08
SCALE NTS	SHEET No. 1 OF 1		